

BRUSH HAWG MODEL AWC STANDARD FEATURES

30" DIAMETER SLEWING RING BEARING

PLANETARY GEAR BOX WITH DISC DRIVE MOTOR

IN-CAB, SIT-DOWN JOYSTICK CONTROLS UTILIZING MULTIPLE CAMERA SYSTEMS AND CAB WINDOWS TO OPERATE LOADER

18' TAPERED DUMP BODY (42"-62")

SINGLE SIDE-HINGED TAILGATE WITH (3) HINGE ASSEMBLIES

15 TON SCISSOR HOIST

4-WAY ADJUSTABLE STABILIZERS

MAIN BOOM, TIP BOOM, & TIP BOOM EXTENSION

HEAVY DUTY BUCKET WITH 360 DEGREE ROTATOR (NO STOPS)

HOT SHIFT PTO, TANDEM STAGE DM PUMP, & EOS

COLOR LCD REAR VISION CAMERA SYSTEM (CHASSIS-REVERSE)

ALL LED BODY LIGHTS

DUAL UPPER TAILGATE BRAKE LIGHTS

DUAL UPPER TAILGATE AMBER STROBING LIGHTS

DUAL FRONT BUMPER WORK LIGHTS

DUAL BOOM AND CURBSIDE (UNDER BODY) WORK LIGHTS

ELECTRIC TARP SYSTEM WITH ALUMINUM ARMS

MOUNTED ON SUITABLE FACTORY SUPPLIED FREIGHTLINER CREW CAB

PAINTED BH YELLOW & BH GREEN (LOADER & DUMP BODY)

DUMP BODY UNDERCOATING

OWNER/OPERATOR TRAINING

STANDARD WARRANTY

BRUSH HAWK

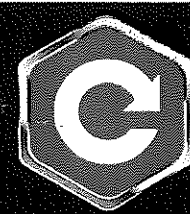

Brush and Limb Loader
All Weather Cab (AWC) Model

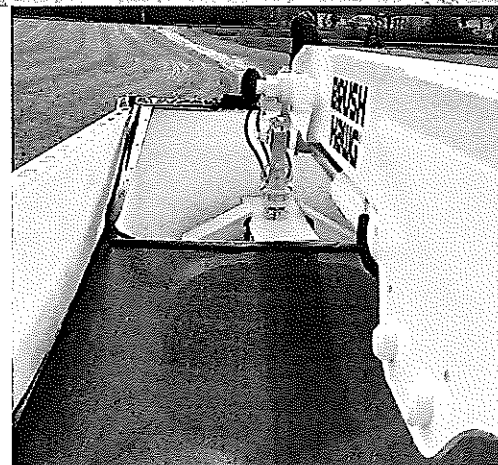

CURBTENDER
SWEEPERS, LLC

701 PERFORMANCE DRIVE | CEDAR FALLS, IA 50613
PHONE: (319) 266-1721 | FAX: (319) 266-8207
www.curbtendersweepers.com

BODY SPECIFICATIONS

| | | |
|---|-------------------|-------------------|
| Body Capacity | 26yd ³ | 30yd ³ |
| A. Body Length | 18' | 20' |
| B. Minimum Cab to Body Spacing | 16" | 16" |
| C. Box Front Sill Height | 42" | 42" |
| D. Estimated Ground to Top of Boom | 11' | 11' |
| E. Box Rear Sill Height | 74" | 74" |
| F. Minimum Cab to Axle | 186" | 210" |
| Dump Capacity (Dependent on Lift Hoist Option) | 15 or 23 Tons | 15 or 23 Tons |
| Approximate Body Weight | 5,500 LBS. | 6,000 LBS. |

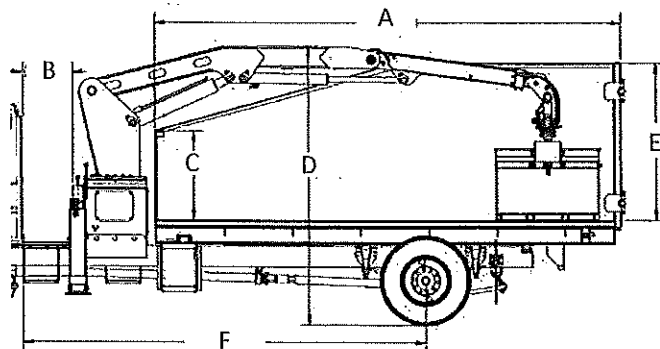

MINIMUM CHASSIS REQUIREMENTS

| | 18' Dump Bed | 20' Dump Bed |
|---|--|---------------|
| Minimum GVWR | 33,000 LBS. | 33,000 LBS. |
| Front Axle | 12,000 LBS. | 12,000 LBS. |
| Rear Axle & Suspension (minimum) | 21,000 LBS. | 21,000 LBS. |
| Rear Axle & Suspension (recommended) | 23,000 LBS. | 23,000 LBS. |
| Cab to Axle | 186" | 210" |
| Frame Rails | 1,800,000 RBM | 1,800,000 RBM |
| Additional Requirements | <ul style="list-style-type: none"> • Evaluation of Exhaust Placement and Type Required to Check Clearances for Boom Mounting and Ground Clearance in Uneven Terrain • Horizontal Exhaust with Tailpipe Extended and Turned Outward Ahead of Rear Tires • Clean Frame Rails Back of Cab Fuel and DEF Tank Protuding Beyond BOC Requires Modification of Steps for 24" Deck • Tires, 11R22.5 | |

All Weather Cab (AWC)

- Freightliner M2 Crew Cab Chassis, Built Exclusively for Brush Hawk
- Single Operator's Seat in Rear Cab
- Multiple Camera Systems, Along w/ Custom Crew Cab, Roof Window, and Large Rear Window Allowing Operator to Work Inside Truck Cab in a Safe, Comfortable Environment

Features

- Roll-Rite Electric Tarp System
- 4-way Adjustable Stabilizers
- 30" Diameter Slewing Bearing
- Planetary Gear Drive
- Single Stage Direct-Mount Pump
- Telescopic Tip Boom Extension
- Continuous Bucket Rotator
- 15-Ton Scissor Hoist

Engine/Powertrain

- Allison 3000 Series (Minimum)
- Allison 3500 RDS, 6 Speed (Recommended)
- 260HP, 660 FT/LBS. Torque

Grapple Loader

- Up to 20' Reach in All Directions
- Over 9,000 LBS. Lift Capacity
- In-Cab Joystick Controls (4-Door Cab Chassis)

Dump Body

- Standard C-Model Loader/Dump Body
- 18' Tapered Dump Body (42" - 74")
- Factory Mounting and Painting
- Dump Body Undercoating

Lighting

- LED Clearance and Tail Lights

Controls

- Patented In-Cab Control System (U.S. Patent #10196098)
- Air/Electric-Over-Hydraulic Joystic Controls in Rear Cab

Warranty

- 1 Year Parts and Labor Warranty
- 3 Years Structural Warranty