



POWERFLEX

AEH



AIR COMPRESSOR



GENERATOR



HYDRAULIC PUMP

The Trifecta of Functionality!

Air Compressor, AC Generator, Hydraulic Output.

The PowerFlex™ AEH is equipped with a 40 CFM at 150 PSI rotary screw air compressor, a 6,800 watt AC generator, and powerful hydraulic pump, providing 13 GPM and up to 3000 PSI for crane operation. Save fuel costs and increase your productivity.



SPECIFICATIONS	
CFM Rating	40 CFM @ High Speed / 30 CFM @ Idle Speed
Air Pressure	150 PSI
AC Generator	6.8 kW @ 60 Hz, 120 / 240V
Compressor Type	Rotary Screw
Hydraulic Flow*	Up to 13 GPM
Hydraulic Pressure *	Up to 3000 PSI
Engine Type	25 HP Kubota® Tier 4 Final
Drive System	Belt Driven
Fuel Type	Diesel

Powerflex™ AEH Unit Dimensions with fittings (In.): 47.6 L x 21.0 W x 33.4 H
Dry Weight (Lbs.): 870

AIR COMPRESSOR

- 40 CFM Rotary Screw Encapsulated Air End
- Belt-Driven
- Lifetime Warranty on Air End
- Integrated Inlet

GENERATOR

- 6.8 kW Continuous @ 60 HZ
- Brushless Design
- Smooth Wave for Minimal Distortion

COOLING SYSTEM

- Air-To-Oil Compressor Fluid Cooler
- Ambient Operating Conditions from -20°F to 110°F

HYDRAULICS

- Rated @ 10.5 GPM @ 2000 PSI and 8.5 GPM @ 3000 PSI
- Variable Displacement Pump

REMOTE CONTROL PANEL

- Remote Mountable for Convenient and Safe User Use
- Engine Start / Stop
- Engine Fault Lights
- Hour Meter
- Switch Override
- Compressor / Hydraulic On / Off Switch
- Speed Control Switch
- Compressor Fault Light

MAINTENANCE/SERVICEABILITY

- Hinged Top and Removable Front Panel for Easy Access
- Spin On Air-Oil Separator Element for Easy Maintenance

CANOPY

- Powder-Coated Galvanneal Sheet Metal Enclosure
- Lifting Bail

SAFETY EQUIPMENT

- Low Engine Oil Shut Down
- Alternator Failure Indicator
- Service Access Door Shut Down
- Engine Over Temperature Shut Down
- Air Pressure Safety Relief Valve And Automatic Blow-Down On Shut Down
- High-Temperature & High-Pressure Compressor Shut Down
- Oil Fill Plug Safety Relief
- Hydraulic Oil Pressure-Relief Valve

OPTIONS/ACCESSORIES

- Air Reservoir Tanks
- After Coolers
- Air Hoses
- Filter/Regulator/Lubricators
- Hose Reels
- OSHA Valves
- Moisture Separators
- Tool Oilers
- Air Tools
- Maintenance Kits
- Battery Harness

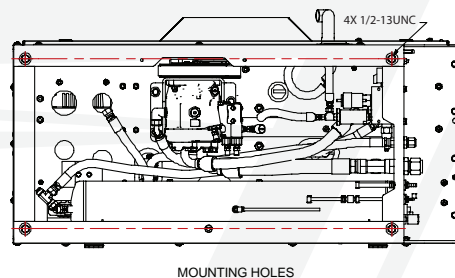
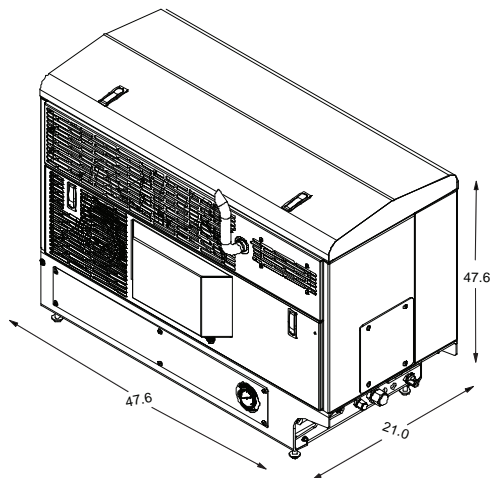

MOUNTING HOLES

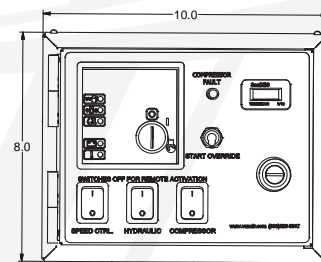

REMOTE PANEL

Vanair reserves the right to make changes in engineering, design, and specifications; add improvements; or discontinue manufacturing at any time without notice or obligation. Vanair, the Vanair logo and MOBILE POWER SOLUTIONS are registered trademarks or trademarks of Vanair Manufacturing, Inc., Michigan City, IN, USA. © 2021 All Rights Reserved.



VANAIR[®]
MOBILE POWER SOLUTIONS[®]

800.526.8817 | vanair.com

FREIGHT NOT
INCLUDED IN
PRICE OF UNIT.
FREIGHT WILL
BE BILLED UPON
PURCHASE.