



ITEM #:	1334
BRAND	Vanair
MODEL	Air n Arc 150
DISCOUNT	10%

Options:

MODEL	MSRP	DISCOUNTED PRICE
Remote Panel Harness	\$855.00	
Battery Booster Cables	\$205.00	
Cold Weather Kits	\$353.00	

Freight is not included in pricing. Other options available call for availability and pricing.

AIR NARC[®]

150

PERFORMANCE/FEATURES

- Fuel System can be Integrated with the Chassis (Kohler[®] HP 19 & Vanair[®] VNR680 20 HP Only)
- Powder Coated Sheet Metal for Protection
- 100% Duty High Frequency Welder Offering Excellent Weld Characteristics
- Galvannealed Steel Metal
- Heavy Duty Belt Driven System for Anti-Vibration and Long Service Intervals

AIR COMPRESSOR

- Reciprocating Compressor
- Cast Iron Air Pump with Three Cylinder Head Design for Better Cooling
- Factory Set @ 130 PSI (Adjustable to 150 PSI)

WELDER

- Patented Amperage and Power Controls Built Into Welding Lead for Ease of Use for Kohler[®] 14 HP Unit
- 100% Variable Completely Controllable
- Independent Welding Generator
- CV on Remote Panel Machines
- Safe Multi-Function
- Auto Throttle Control

GENERATOR

- True Two-Generator System for Safe Multi-Functioning of Welder and Electric Tools
- Brushless Design (AC)
- Smooth Wave for Minimal Distortion
- Two 120V Outlets and One 240V Outlet Provided

ENGINE

- Kohler[®] 14 HP, Kohler[®] 19 HP, or Vanair[®] VNR680 20 HP
- Electric Start

AVAILABLE FUEL CAPACITY

- 1.9 Gallons (Kohler[®] 14 HP)
- 11.5 Gallons on Models with 30 Gallon Air Storage (Kohler[®] HP 19 & Vanair[®] VNR680 20 HP Only)
- Tied to Chassis

BATTERY BOOST/CHARGE (OPTIONAL)

- 150 AMP 12V/24V Boost (Standard on Remote Panel)
- 50 AMP 12V Charge (Standard on Remote Panel)

REMOTE CONTROL PANEL (OPTIONAL)

- Optional on Kohler[®] 19 & Vanair[®] VNR680 20 HP Systems Only (Harness Not Included)
- Provides Ultimate User Convenience and Safety
- All Functions Accessible at Panel

AVAILABLE AIR RESERVOIRS

- 10 Gallon (14 HP), 30 Gallon, and Skid Mount

OPTIONS/ACCESSORIES

- Remote Panel Harness - 10', 14', 18'
- Remote Mount Control Panel (Kohler[®] 19 HP & Vanair[®] VNR680 20 HP Only)
- Battery Cable Extension - 8', 12', 16', 20', 24'
- Battery Booster Cables
- Fuel Tank – Slim Line 11 Gallon (Kohler[®] HP 19 & Vanair[®] VNR680 20 HP Only)
- Remote Air Tank Options
- Remote Condensation Drain
- Welding Helmet with Auto Darkening Lens
- Dry Cell Battery
- GFCI Outlet for Protection of 120V/240V (Remote Panel Machines Only)
- Filter/Lubricator/Regulator (FLR)
- Hose Reels and Fittings
- OSHA Safety Valve (Velocity Fuse)
- Service/Control Line Moisture Separators
- Tool Oiler/Lubricator
- Cold Weather Kits
- Maintenance Kits
- Hose Reels

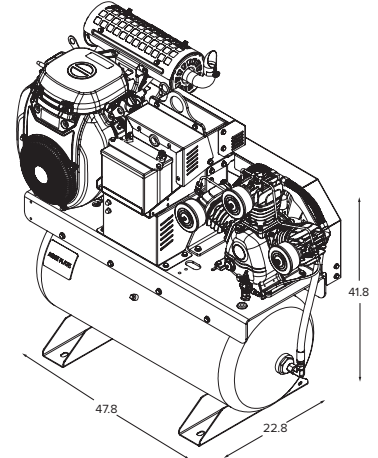

20 HP WITH 30 GALLON TANK

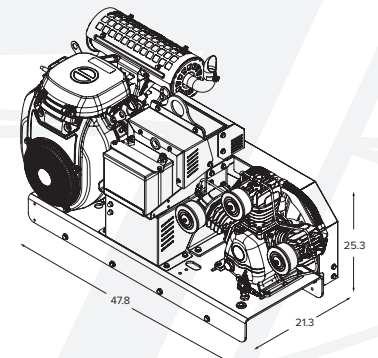

20 HP SKID MOUNT

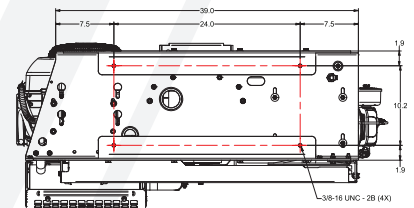

20 HP SKID MOUNT MOUNTING HOLES

Vanair reserves the right to make changes in engineering, design, and specifications; add improvements; or discontinue manufacturing at any time without notice or obligation. Vanair, the Vanair logo and MOBILE POWER SOLUTIONS are registered trademarks or trademarks of Vanair Manufacturing, Inc., Michigan City, IN, USA. © 2023 All Rights Reserved.



800.526.8817 | vanair.com

10896 West 300 North | Michigan City, Indiana 46360 USA



ANA150_041123_NML