



**North Carolina
Sheriff's Association**



FES22-04 Commercial Pumper

June 18, 2022

Attachment A



SAFE INDUSTRIES



PROPOSAL

Fire Equipment Sales and Services is pleased to offer the proposed vehicle to meet the intent of the fire department specifications. Fire Equipment Sales and Services is a manufacturer in commercial fire fighting vehicles.

Fire Equipment Sales and Services

1665 Stamey Livestock Road
Sumter, SC 29153
Office: (803) 494-6000

After Hours Emergency Service Hotline: 1-864-845-7175 Option #3

GENERAL INFORMATION

The proposed apparatus will be constructed to withstand the severe and continuous use encountered during emergency fire fighting services. The apparatus will be of the latest type, carefully designed and constructed with due consideration to the nature and distribution of the load to be sustained.

This proposal details the general design criteria of cab and chassis components, aerial device (if applicable), fire pump and related components (if applicable), water tank (if applicable), fire body, electrical components, painting, and equipment.

All items of these proposal specifications will conform to the fullest extent possible with the National Fire Protection Association Pamphlet No. 1901, latest edition, except as noted in the Statement-of-Exceptions.

FES will furnish satisfactory evidence of our ability to construct, supply service parts and technical assistance for the apparatus specified.



FIRE APPARATUS COMPLETION DOCUMENTATION

Fire Equipment Sales and Services will provide, at the time of apparatus delivery, at least one (1) copy of the following documents.

The apparatus manufacturer's record of apparatus construction (build) details, including the information listed below:

- Apparatus Owner's name and address
- Apparatus manufacturer, model and serial number
- Apparatus Chassis make, model and serial number
- Front tire size, and total rated capacity (in pounds)
- Rear tire size, and total rated capacity (in pounds)
- Apparatus Chassis weight distribution in pounds, with water and equipment mounted, front and rear
- Apparatus Engine make, model, serial number, rated horse power, rated speed and governed speed.
- Type of fuel(s) used by apparatus and fuel tank(s) capacity
- Apparatus electrical system - Voltage and Alternator output (in amps)
- Battery make, model and total capacity (in cold crank amps)
- Transmission make, model and serial number: If equipped, chassis transmission PTO(s) make, model and gear ratio
- Pump make, model, rated capacity in gallons per minute (GPM) and serial number
- Apparatus water tank certified capacity in gallons
- Paint manufacturer and paint number(s)

The apparatus manufacturer will include certification of "slip resistance" for all stepping, standing and walking surfaces.

If the apparatus has a fire pump, the following additional documents will be provided:

- The pump manufacturer's certification of suction capability
- Copy of the apparatus manufacturer's approval for stationary pumping applications
- Engine manufacturer's certified brake horsepower curve for the engine provided, showing the maximum governed speed.
- Pump manufacturer's certification of hydrostatic test (if it applies)
- The independent third party certification of inspection and test for the apparatus fire pump

If the apparatus has a "fixed line" voltage power source, there will be documentation of the fixed power source test certification.

If the apparatus features an air system, there will be test results of the air quality, SCBA fill station and the installation of the air system.

The apparatus manufacturer will provide documentation from a certified weight scale. This documentation will show actual loading on the front axle, rear axle(s) and overall vehicle weight. This weight will include the weight of the "full" apparatus water tank. This documentation will be provided with the completed apparatus build to determine compliance with NFPA 1901 latest addition.

Electrical performance testing documentation and a written load analysis report will be provided with the completed apparatus.

If the apparatus features a water tank, the water tank capacity certification will be supplied by the tank manufacturer.



APPARATUS FMVSS CERTIFICATION

The proposed chassis will be certified by FES as conforming to all applicable Federal Motor Vehicle Safety Standards (FMVSS) in effect at the date of contract. This will be attested to by the attachment of a FMVSS certify caution label on the vehicle by FES, who will be recognized as the responsible final manufacturer.

APPARATUS RECORDS RETENTION

FES will be responsible for preparing and maintaining a record file of parts and assemblies used to manufacture the proposed apparatus.

These records will be maintained in FES's factory for a minimum of twenty (20) years.

The file will contain copies of any and all reported deficiencies, all replacement parts required to maintain the apparatus, and original purchase documents including specifications, contract, invoices, incomplete chassis certificates, quality control reports and final delivery acceptance documents. The purchaser will have access to any and all documents contained in this file upon official written request.

GENERAL CONSTRUCTION

The proposed apparatus, assemblies, subassemblies, component parts, etc., will be designed and constructed with the due consideration to the nature and distribution of the load to be sustained and to the general character of the service to which the apparatus is subjected to when placed in service. All parts of the apparatus will be designed with a factor of safety, which is equal to or greater than that which is considered standard and acceptable for this class of equipment in fire fighting service. All parts of the proposed apparatus will be strong enough to withstand general service under full load. The apparatus will be so designed that the various parts are readily accessible for lubrication, inspection, adjustment and repair.

The apparatus will be designed and constructed, and the equipment so mounted, with due consideration to distribution of the load between front and rear axles that all specified equipment, including a full complement of specified ground ladders, full water tank, loose equipment, and firefighters will be carried without overloading or injuring the apparatus.

SINGLE-LINE RESPONSIBILITY

FES engineers, designs, manufactures, builds and paints our own fire apparatus body, rescue apparatus body and electrical systems. All work is done in an FES owned and operated manufacturing facilities by FES direct employees. This capability provides consistent design and manufacturing procedures that will reduce warranty issues and provide ease in parts replacement.



CERTIFICATE OF LIABILITY INSURANCE

Fire Equipment Sales and Service maintains the following insurance limits:

- Total Garage Keepers Insurance: \$2,500,000.00
- Total Umbrella Liability per Occurrence Insurance: \$4,000,000.00
- Total Automobile Liability Insurance: \$5,000,000.00
- Total General Liability Insurance: \$6,000,000
- Workers Compensation and Employers Liability Insurance: \$6,000,000.00

Reference attached documentation.

PAINT PERFORMANCE CERTIFICATION

The proposed FES apparatus meets or exceeds the required Commercial Vehicle Paint Performance Standards.

SERVICE CENTER AND PARTS AVAILABILITY

Fire Equipment Sales and Services owns and operates a 35,000+ sq. ft. service, fabrication and office complex in Sumter, SC. In addition, our parent company, Safe Industries, has a 18,000 sq. ft. service facility in Piedmont, SC, a 20,000+ sq. ft. office/warehouse complex in Easley, SC and a 6,400 sq. ft. service center in Knoxville, TN.

Average daily parts inventory is in excess of \$500,000.00

FES FIRE APPARATUS SERVICE STATEMENT

Safe Industries is proud to offer over 100 years of combined experience in the fire service and apparatus industry. We offer a twenty-four hour service commitment with thirty (30) service technicians on call and twenty seven (27) service vehicles available across South Carolina, North Carolina and Tennessee.

Our certifications include EVT, ASE, Cummins, Hale, Waterous, Darley, Akron, and Bendix brakes.

We can perform all pump tests at your location with the Draft Commander 3000 mobile pump test trailer, to eliminate removing your apparatus from your department. In case of an emergency we can UN hook from the test and have the apparatus in operation in less than 5 minutes.

Safe Industries is fully insured with Workman's Compensation.

Contact:

Safe Industries

5031 Highway 153
Easley, SC, 29642
Office: (864) 845-7175
Fax: (864) 845-7176
Toll Free: 1-877-997-7233

After Hours Emergency Service Hotline: 1-864-845-7175 Option #3



SERVICE CENTER LOCATION

Safe Industries owns and operates three (3) facilities in the state of South Carolina and one (1) in Tennessee. Our headquarters office is located at 5031 HWY 153 Easley, South Carolina and our service building in the upstate is located at 116 Connector Park Court, Piedmont, SC 29673.

Fire Equipment Sales and Services, a wholly owned division of Safe Industries, is fully equipped with a metal fabrication and welding shop, electrical and plumbing shop, paint booths and in-house graphics.

BST Firetrucks and Emergency Vehicle Service Center was acquired by Safe Industries in 2020. Located at 3150 NW Park Drive, Knoxville, TN 37921, BST's full service facility conducts apparatus modifications, fabrication, collision repairs, pump repairs, NFPA pump and inspections tests and a wide range of diagnostic testing.

SERVICE TECHNICIANS

Safe Industries has company owned service vehicles that will be available 24 hours a day, seven days a week to respond to customer needs. The Service Vehicles will be operated by full time EVT Certified Technicians.

PRICES AND PAYMENTS

The apparatus bid price will be FOB FES, based on a delivered and accepted apparatus by the Fire Department.

The total price on the Fire Equipment Sales and Services proposal sheet will include all items listed in the apparatus specifications.

The computed pricing does not include federal, state or local taxes. Any applicable taxes will be added to the proposed pricing. Tax-exempt forms may be provided if applicable for tax-exempt agencies.

APPARATUS DELIVERY TIME

Fire Equipment Sales and Services is proposing to complete the apparatus delivery time based on the number of working days, starting from the date an approved commercial chassis is received by the manufacturer.

Apparatus Delivery Time: One Hundred Eighty (180) working days after receipt of approved chassis by FES.

FAIR, ETHICAL AND LEGAL COMPETITION

In order to provide fair, ethical and legal competition, the original equipment manufacturer (OEM) or the parent company of the OEM will not have ever been fined or convicted of the following in any domestic or international fire apparatus market:

- Price Fixing
- Bid Rigging
- Collusion



NON-COLLUSIVE BIDDING CERTIFICATION

By submission of this bid, FES and each person signing on behalf of any bidder, certifies, and in the case of a joint bid, each party thereof certifies as to its own organization, under penalty of perjury, that to the best of their knowledge and belief:

- The prices in this bid have been arrived at independently without collusion, consultation, communication, or agreement, for purpose of restricting competition, as to any matter relating to sell prices with any other bidder or any competitor.
- Unless otherwise required by law, the prices that have been quoted in this bid have not been knowingly disclosed by FES and will not knowingly be disclosed by FES prior to opening, directly or indirectly, to any other bidder or to any competitor
- No attempt has been made by FES to induce any other person, partnership, or corporation to submit or not to submit a bid for the purpose of restricting competition.
- That all requirements of the law including amendatory provisions as to non-collusive bidding have been complied with.

MATERIAL AND WORKMANSHIP

All equipment provided will be guaranteed by Fire Equipment Sales and Services to be new and of current manufacture to meet all requirements of the purchaser's specifications.

All workmanship will be of highest quality meeting accepted standards of the apparatus industry and will be accomplished in a professional manner so as to insure a functional apparatus with a pleasing, aesthetic appearance.

FES ENGINEER

Fire Equipment Sales and Services will designate a representative to perform FES's sales engineer functions. The sales engineer will provide a single point interface between the purchaser and FES on all matters concerning the apparatus contract.

APPARATUS DELIVERY

Final approval, acceptance, payment and delivery shall take place at the manufacturing facility, Fire Equipment Sales and Service, at the final inspection of the apparatus.

INSTRUCTION MANUALS / DRAWINGS

Fire Equipment Sales and Services will supply upon delivery two (2) copies of operation and service manual(s) for the completed apparatus as delivered and accepted by the customer.

These manuals will contain the items below:

- Specifications, descriptions and ratings of chassis, and pump (if provided).
- Lubrication (fluids) charts
- Operational instructions for the apparatus chassis and any major components such as a pump or auxiliary system.
- Instructions regarding the frequency and maintenance procedures recommended for the apparatus.
- Replacement parts information.



VEHICLE FLUIDS PLATE

As required by NFPA-1901, FES will affix a permanent plate in the driver's compartment specifying the quantity and type of the following fluids used in the vehicle:

A permanent plate in the driving compartment will specify the quantity and type of the following fluids used in the vehicle:

- Engine oil
- Engine coolant
- Chassis transmission fluid
- Pump transmission lubrication fluid
- Pump primer fluid
- Drive axle(s) lubrication fluid
- Air-conditioning refrigerant
- Air-conditioning lubrication oil
- Power steering fluid
- Transfer case fluid
- Equipment rack fluid
- Air compressor system lubricant
- Generator system lubricant

LOCATION OF MANUFACTURING FACILITY

Fire Equipment Sales and Services is located at 1665 Stamey Livestock Road in Sumter, South Carolina, 29153. We maintain a 36,000 square foot facility that is state of the art in fire apparatus manufacturing. It is the largest Fire Apparatus Manufacturing and service facility in Virginia, North Carolina and South Carolina.

Our equipment includes a precision water-jet cutter, 65' downdraft environmentally friendly paint booth as well as tig, mig, heliarc welders as well as plasma cutters.

PROPOSAL BLUEPRINT

FES is providing a scaled drawing of the specific apparatus being proposed with the bid. The drawing has been generated by FES's engineering department in order to maintain the accuracy of the drawing.

FIRE APPARATUS MANUFACTURER'S ASSOCIATION MEMBERSHIP

Fire Equipment Sales and Services, a wholly owned division of Safe Industries, is honored to be a member of the Fire Apparatus Manufacturers Association.

SOUTH CAROLINA DEALER'S LICENSE

Safe Industries is a fully licensed South Carolina Motor Vehicle Dealer. A copy of a valid, current license will be included with the submission of this proposal.

U.S.A. MANUFACTURER

The entire apparatus will be assembled within the borders of the Continental United States to insure more readily available parts (without added costs and delays caused by tariffs and customs) and service.



TAG ON'S/ADDITIONAL ORDERS

At its sole discretion, the Manufacturer may allow the terms of this contract to be extended to both the purchaser and similar agencies for the purchase of a similar unit(s) under similar terms for a period of 36 months from the date of the execution of this contract. Should the Manufacturer choose to exercise this option, it will be permitted to adjust the contract pricing to account for equitable price adjustments associated with the change in the cost of the materials used to produce the unit as well as normal manufacturer yearly price increases. If there are any changes between the unit(s) purchased via this contract and any subsequent orders, those changes must be documented via properly signed and executed change orders, including any necessary price adjustments. If the purchasing agency is not the purchaser, a separate contract will be required to complete the additional purchases. This includes any similar Apparatus, Loose Equipment options, and Service and Warranty Plans.

EXAMINATION & TEST PROPOSAL COMPLETED BY CERTIFIED THIRD PARTY

If required by the specific chapters of NFPA-1901, the proposed unit shall be tested by a company certified third party company.

A complete written examination and test report will be provided for each inspection performed at the manufacturer's facility. This report specifies the points of inspection and results of such examinations and tests.

The company providing the test work on the units shall be certified to Level II in the required NDT methods, under the requirements outlined in ASNT document CP-189.

The actual person(s) performing the inspection shall present for review proof of Level II Certification in the required NDT methods.

FES will designate, in writing, who is qualified to witness and certify these test results.

Prior to submittal to the automotive fire apparatus manufacturer, the final Report shall be reviewed by an authorized representative of Fire Equipment Sales and Services and a Registered Professional Engineer.

When the unit successfully meets all the requirements outlined in NFPA 1901, 2016 Edition, the company completing these tests shall issue a Certificate of Automotive Fire Apparatus Examination and Test stating the unit's compliance with NFPA- 1901.

FULL TIME SERVICE AND WARRANTY STAFF

Safe Industries has seven (7) full time employees on staff dedicated to our service center's apparatus parts and warranty division. Safe Industries also employees one (1) dedicated full time employee to warranty.



GENERAL APPARATUS DESCRIPTION "PUMPER"

The unit will be designed to conform fully to the "Pumper Fire Apparatus" requirements as stated in the NFPA 1901 Standard (2016 Revision), which will include the following required chapters as stated in this revision:

- Chapter 1 Administration
- Chapter 2 Referenced Publications
- Chapter 3 Definitions
- Chapter 4 General Requirements
- Chapter 5 Pumper Fire Apparatus
- Chapter 12 Chassis and Vehicle Components
- Chapter 13 Low Voltage Electrical Systems and Warning Devices
- Chapter 14 Driving and Crew Areas
- Chapter 15 Body, Compartments and Equipment Mounting
- Chapter 16 Fire Pumps and Associated Equipment
- Chapter 18 Water Tanks

CAB SAFETY SIGNS

The following safety signs will be provided in the cab:

- A label displaying the maximum number of personnel the vehicle is designed to carry will be visible to the driver.
- "Occupants will be seated and belted when apparatus is in motion" signs will be visible from each seat.
- "Do Not Move Apparatus When Light Is On" sign adjacent to the warning light indicating a hazard if the apparatus is moved (as described in subsequent section).
- A label displaying the height, length, and GVWR of the vehicle will be visible to driver.
- This label will indicate that the fire department will revise the dimension if vehicle height changes while vehicle is in service.



CHASSIS DATA LABELS

The following information will be on labels affixed to the vehicle:

Fluid Data:

- Engine Oil
- Engine Coolant
- Chassis Transmission Fluid
- Pump Transmission Lubrication Fluid
- Pump Primer Fluid (if applicable)
- Drive Axle(s) Lubrication Fluid
- Air Conditioning Refrigerant
- Air Conditioning Lubrication Oil
- Power Steering Fluid
- Cab Tilt Mechanism Fluid
- Transfer Case Fluid (if applicable)
- Equipment Rack Fluid (if applicable)
- Air Compressor System Lubricant
- Generator System Lubricant (if applicable)
- Front Tire Cold Pressure
- Rear Tire Cold Pressure
- Aerial Hydraulic Fluid (if applicable)
- Maximum Tire Speed Rating

Chassis Data:

- Chassis Manufacturer
- Production Number
- Year Built
- Month Manufactured
- Vehicle Identification Number

Manufacturers weight certification:

- Gross Vehicle (or Combination) Weight Rating (GVWR or GCWR)
- Gross Axle Weight Rating, Front
- Gross Axle Weight Rating, Rear



PRINCIPAL APPARATUS DIMENSIONS & G.V.W.R.

- Overall Length: TBD"
- Overall Width: 100"
- Overall Height: TBD"
- Wheelbase: TBD"

The axle and total weight ratings of the completed apparatus will not be less than the following minimum acceptable weight ratings:

- Minimum Front G.A.W.R.: 14,600 lbs.
- Minimum Rear G.A.W.R.: 26,000 lbs.
- Minimum Total G.V.W.R.: 40,600 lbs.

FES will include the principal dimensions, front G.A.W.R., rear G.A.W.R., and total G.V.W.R. of the proposed apparatus. Additionally, FES will provide a weight distribution of the fully loaded, completed vehicle; this will include a filled water tank, specified hose load, miscellaneous equipment allowance in accordance with NFPA-1901 requirements, and an equivalent personnel load of 250 lbs. per seating position.



CHASSIS SPECIFICATIONS

Data Code	Description	Weight Front	Weight Rear
Price Level			
PRL-26M	M2 PRL-26M (EFF:7/26/21)		
Data Version			
DRL-042	SPECPRO21 DATA RELEASE VER 042		
Vehicle Configuration			
001-172	M2 106 CONVENTIONAL CHASSIS	5,709	3,503
004-223	2023 MODEL YEAR SPECIFIED		
002-004	SET BACK AXLE - TRUCK		
019-002	STRAIGHT TRUCK PROVISION		
003-001	LH PRIMARY STEERING LOCATION		
General Service			
AA1-002	TRUCK CONFIGURATION		
AA6-002	DOMICILED, USA (EXCLUDING CALIFORNIA AND CARB OPT-IN STATES)		
A85-020	FIRE SERVICE		
A84-1EV	EMERGENCY VEHICLES BUSINESS SEGMENT		
AA4-002	LIQUID BULK COMMODITY		
AA5-002	TERRAIN/DUTY: 100% (ALL) OF THE TIME, IN TRANSIT, IS SPENT ON PAVED ROADS		
AB1-008	MAXIMUM 8% EXPECTED GRADE		
AB5-001	SMOOTH CONCRETE OR ASPHALT PAVEMENT - MOST SEVERE IN-TRANSIT (BETWEEN SITES) ROAD SURFACE		
995-091	MEDIUM TRUCK WARRANTY		
A66-99D	EXPECTED FRONT AXLE(S) LOAD : 14600.0 lbs		
A68-99D	EXPECTED REAR DRIVE AXLE(S) LOAD : 26000.0 lbs		
A63-99D	EXPECTED GROSS VEHICLE WEIGHT CAPACITY : 40600.0 lbs		
Truck Service			
AA3-027	FIRE TANK/PUMPER - MAIN DRIVELINE DRIVEN SPLIT-SHAFT PTO/PUMP		
AF3-1U7	FIRE EQUIPMENT SERVICES		
AF7-99D	EXPECTED BODY/PAYLOAD CG HEIGHT ABOVE FRAME "XX" INCHES : 32.0 in		
Engine			
101-3B0	CUM L9 360EV HP @ 2200 RPM, 2200 GOV RPM, 1150 LB-FT @ 1200 RPM, R/F/E	640	30
Electronic Parameters			
79A-068	68 MPH ROAD SPEED LIMIT		
79B-000	CRUISE CONTROL SPEED LIMIT SAME AS ROAD SPEED LIMIT		
79K-007	PTO MODE ENGINE RPM LIMIT - 1100 RPM		
79M-001	PTO MODE BRAKE OVERRIDE - SERVICE BRAKE APPLIED		
79P-002	PTO RPM WITH CRUISE SET SWITCH - 700 RPM		



Data Code	Description	Weight Front	Weight Rear
79Q-003	PTO RPM WITH CRUISE RESUME SWITCH - 800 RPM		
79S-001	PTO MODE CANCEL VEHICLE SPEED - 5 MPH		
79U-007	PTO GOVERNOR RAMP RATE - 250 RPM PER SECOND		
79V-001	FUEL DOSING OF AFTERTREATMENT ENABLED IN PTO MODE-CLEANS HYDROCARBONS AT HIGH TEMPERATURES ONLY		
80E-001	ENGINE FAN ENABLED WITH RETARDER		
80G-002	PTO MINIMUM RPM - 700		
80H-004	CUMMINS EMERGENCY VEHICLE THROTTLE CONTROL OPTION		
80J-002	REGEN INHIBIT SPEED THRESHOLD - 5 MPH		
Engine Equipment			
99C-021	2010 EPA/CARB/GHG21 CONFIGURATION		
13E-001	STANDARD OIL PAN		
105-001	ENGINE MOUNTED OIL CHECK AND FILL		
014-1BX	SIDE OF HOOD AIR INTAKE WITH NFPA COMPLIANT EMBER SCREEN AND FIRE RETARDANT DONALDSON AIR CLEANER		
124-120	LN 12V 320 AMP 4962PGH PAD MOUNT ALTERNATOR	10	
292-235	(2) DTNA GENUINE, FLOODED STARTING, MIN 2000CCA, 370RC, THREADED STUD BATTERIES	10	
290-017	BATTERY BOX FRAME MOUNTED		
281-001	STANDARD BATTERY JUMPERS		
282-001	SINGLE BATTERY BOX FRAME MOUNTED LH SIDE UNDER CAB		
291-017	WIRE GROUND RETURN FOR BATTERY CABLES WITH ADDITIONAL FRAME GROUND RETURN		
289-001	NON-POLISHED BATTERY BOX COVER		
87P-001	CAB AUXILIARY POWER CABLE	5	
33M-001	AUXILIARY POWER NET DISTRIBUTION BLOCK FOR BODY BUILDER USE	5	
107-032	CUMMINS TURBOCHARGED 18.7 CFM AIR COMPRESSOR WITH INTERNAL SAFETY VALVE		
108-002	STANDARD MECHANICAL AIR COMPRESSOR GOVERNOR		
131-013	AIR COMPRESSOR DISCHARGE LINE		
152-039	GVG, FIRE AND EMERGENCY SERVICE VEHICLES ENGINE WARNING		
128-1AN	C-BRAKE BY JACOBS WITH HIGH MED LOW BRAKE WITH BRAKE LAMPS	80	
016-1DC	RH OUTBOARD UNDER STEP MOUNTED HORIZONTAL AFTERTREATMENT SYSTEM ASSEMBLY WITH RH HORIZONTAL TAILPIPE EXITING FORWARD OF REAR TIRES	10	5
28F-007	ENGINE AFTERTREATMENT DEVICE, AUTOMATIC OVER THE ROAD ACTIVE REGENERATION AND DASH MOUNTED SINGLE REGENERATION REQUEST/INHIBIT SWITCH		
239-001	STANDARD EXHAUST SYSTEM LENGTH		
237-022	RH HORIZONTAL TAILPIPE, EXIT FORWARD OF REAR TIRES	20	20



Data Code	Description	Weight Front	Weight Rear
23U-001	6 GALLON DIESEL EXHAUST FLUID TANK		
30N-003	100 PERCENT DIESEL EXHAUST FLUID FILL		
43X-002	LH MEDIUM DUTY STANDARD DIESEL EXHAUST FLUID TANK LOCATION		
23Y-001	STANDARD DIESEL EXHAUST FLUID PUMP MOUNTING		
43Y-001	STANDARD DIESEL EXHAUST FLUID TANK CAP		
273-058	AIR POWERED ON/OFF ENGINE FAN CLUTCH		
276-002	AUTOMATIC FAN CONTROL WITH DASH SWITCH AND INDICATOR LIGHT, NON ENGINE MOUNTED		
110-003	CUMMINS SPIN ON FUEL FILTER		
118-008	COMBINATION FULL FLOW/BYPASS OIL FILTER		
266-013	1100 SQUARE INCH ALUMINUM RADIATOR	70	
103-039	ANTIFREEZE TO -34F, OAT (NITRITE AND SILICATE FREE) EXTENDED LIFE COOLANT		
171-007	GATES BLUE STRIPE COOLANT HOSES OR EQUIVALENT		
172-001	CONSTANT TENSION HOSE CLAMPS FOR COOLANT HOSES		
270-008	AUXILIARY ENGINE COOLING USING WATER FROM FIRE PUMP	10	
168-002	LOWER RADIATOR GUARD		
134-001	ALUMINUM FLYWHEEL HOUSING		
132-004	ELECTRIC GRID AIR INTAKE WARMER		
155-058	DELCO 12V 38MT HD STARTER WITH INTEGRATED MAGNETIC SWITCH		

Transmission

342-1KD	ALLISON 3000 EVS AUTOMATIC TRANSMISSION WITH PTO PROVISION	200	60
---------	--	-----	----

Transmission Equipment

343-331	ALLISON VOCATIONAL PACKAGE 198 - AVAILABLE ON 3000/4000 PRODUCT FAMILIES WITH VOCATIONAL MODEL EVS		
84B-003	ALLISON VOCATIONAL RATING FOR FIRE TRUCK/EMERGENCY VEHICLE APPLICATIONS AVAILABLE WITH ALL PRODUCT FAMILIES		
84C-022	PRIMARY MODE GEARS, LOWEST GEAR 1, START GEAR 1, HIGHEST GEAR 5, AVAILABLE FOR 3000/4000 PRODUCT FAMILIES ONLY		
84D-022	SECONDARY MODE GEARS, LOWEST GEAR 1, START GEAR 1, HIGHEST GEAR 5, AVAILABLE FOR 3000/4000 PRODUCT FAMILIES ONLY		
84E-000	PRIMARY SHIFT SCHEDULE RECOMMENDED BY DTNA AND ALLISON, THIS DEFINED BY ENGINE AND VOCATIONAL USAGE		
84F-000	SECONDARY SHIFT SCHEDULE RECOMMENDED BY DTNA AND ALLISON, THIS DEFINED BY ENGINE AND VOCATIONAL USAGE		
84G-000	PRIMARY SHIFT SPEED RECOMMENDED BY DTNA AND ALLISON, THIS DEFINED BY ENGINE AND VOCATIONAL USAGE		
84H-000	SECONDARY SHIFT SPEED RECOMMENDED BY DTNA AND ALLISON, THIS DEFINED BY ENGINE AND VOCATIONAL USAGE		



Data Code	Description	Weight Front	Weight Rear
84J-002	2ND GEAR ENGINE BRAKE PRESELECT RANGE WITH LESS AGGRESSIVE DOWNSHIFT STRATEGY		
84K-000	ENGINE BRAKE RANGE ALTERNATE PRESELECT RECOMMENDED BY DTNA AND ALLISON, THIS DEFINED BY ENGINE AND VOCATIONAL USAGE		
84N-200	FUEL SENSE 2.0 DISABLED - PERFORMANCE - TABLE BASED		
84U-000	DRIVER SWITCH INPUT - DEFAULT - NO SWITCHES		
84M-001	PUMP MODE INPUT ENABLED 3RD/4TH LOCKUP WIRED ON TCM INPUT AJ/BQ - ALLISON 5TH GEN TRANSMISSIONS		
85B-004	4TH RANGE INDICATION ON TCM OUTPUT C - ALLISON 5TH GEN TRANSMISSIONS		
353-026	VEHICLE INTERFACE WIRING CONNECTOR WITH PDM AND NO BLUNT CUTS, AT BACK OF CAB		
34C-002	ELECTRONIC TRANSMISSION CUSTOMER ACCESS CONNECTOR MOUNTED BACK OF CAB		
362-807	CUSTOMER INSTALLED MUNCIE CS41 SERIES PTO		
363-002	PTO MOUNTING, RH SIDE OF MAIN TRANSMISSION ALLISON & EATON FULLER		
341-018	MAGNETIC PLUGS, ENGINE DRAIN, TRANSMISSION DRAIN, AXLE(S) FILL AND DRAIN		
345-003	PUSH BUTTON ELECTRONIC SHIFT CONTROL, DASH MOUNTED		
97G-004	TRANSMISSION PROGNOSTICS - ENABLED 2013		
370-015	WATER TO OIL TRANSMISSION COOLER, IN RADIATOR END TANK		
346-003	TRANSMISSION OIL CHECK AND FILL WITH ELECTRONIC OIL LEVEL CHECK		
35T-001	SYNTHETIC TRANSMISSION FLUID (TES-295 COMPLIANT)		

Front Axle and Equipment

400-099	MFS-14-143A 14,700# FF1 71.5 INCH KPI/3.74 INCH DROP SINGLE FRONT AXLE	60	
402-049	MERITOR 16.5X5 Q+ CAST SPIDER CAM FRONT BRAKES, DOUBLE ANCHOR, FABRICATED SHOES		
403-026	FIRE AND EMERGENCY SEVERE SERVICE, NON-ASBESTOS FRONT LINING		
419-001	CAST IRON OUTBOARD FRONT BRAKE DRUMS		
409-006	FRONT OIL SEALS		
408-001	VENTED FRONT HUB CAPS WITH WINDOW, CENTER AND SIDE PLUGS - OIL		
416-022	STANDARD SPINDLE NUTS FOR ALL AXLES		
405-002	MERITOR AUTOMATIC FRONT SLACK ADJUSTERS		
536-012	TRW TAS-85 POWER STEERING	40	
539-003	POWER STEERING PUMP		
534-015	2 QUART SEE THROUGH POWER STEERING RESERVOIR		



Data Code	Description	Weight Front	Weight Rear
40T-001	MINERAL SAE 80/90 FRONT AXLE LUBE		
Front Suspension			
620-010	14,600# TAPERLEAF FRONT SUSPENSION	170	
619-005	MAINTENANCE FREE RUBBER BUSHINGS - FRONT SUSPENSION		
410-001	FRONT SHOCK ABSORBERS		
Rear Axle and Equipment			
420-022	RS-26-185 26,000# T-SERIES SINGLE REAR AXLE		255
421-489	4.89 REAR AXLE RATIO		
424-001	IRON REAR AXLE CARRIER WITH STANDARD AXLE HOUSING		
386-073	MXL 17T MERITOR EXTENDED LUBE MAIN DRIVELINE WITH HALF ROUND YOKES		
452-001	DRIVER CONTROLLED TRACTION DIFFERENTIAL - SINGLE REAR AXLE		20
878-018	(1) DRIVER CONTROLLED DIFFERENTIAL LOCK REAR VALVE FOR SINGLE DRIVE AXLE		
87B-005	BUZZER AND BLINKING LAMP WITH EACH MODE SWITCH, DIFFERENTIAL UNLOCK WITH IGNITION OFF, ACTIVE <5 MPH		
423-010	MERITOR 16.5X7 P CAST SPIDER CAM REAR BRAKES, DOUBLE ANCHOR, CAST SHOES		20
433-025	FIRE AND EMERGENCY SEVERE SERVICE NON-ASBESTOS REAR BRAKE LINING		
434-011	BRAKE CAMS AND CHAMBERS ON FORWARD SIDE OF DRIVE AXLE(S)		
451-030	WEBB HEAVY WEIGHT CAST IRON REAR BRAKE DRUMS		80
425-002	REAR BRAKE DUST SHIELDS		5
440-006	REAR OIL SEALS		
426-1B5	BENDIX EVERSURE LONGSTROKE HEAVY DUTY 30/36 1-DRIVE AXLE SPRING PARKING CHAMBERS		
428-003	HALDEX AUTOMATIC REAR SLACK ADJUSTERS		
41T-001	MINERAL SAE 80/90 REAR AXLE LUBE		
Rear Suspension			
622-1DE	27,000# FLAT LEAF SPRING REAR SUSPENSION WITH HELPER AND RADIUS ROD FOR FIRE/EMERGENCY SERVICE		170
621-004	SPRING SUSPENSION - 1.50" AXLE SPACER		10
431-001	STANDARD AXLE SEATS IN AXLE CLAMP GROUP		
623-005	FORE/AFT CONTROL RODS		
Brake System			
018-002	AIR BRAKE PACKAGE		
490-121	WABCO 4S/4M ABS WITH TRACTION CONTROL		
871-001	REINFORCED NYLON, FABRIC BRAID AND WIRE BRAID CHASSIS AIR LINES		
904-001	FIBER BRAID PARKING BRAKE HOSE		
412-001	STANDARD BRAKE SYSTEM VALVES		



Data Code	Description	Weight Front	Weight Rear
46D-001	STANDARD AIR SYSTEM PRESSURE PROTECTION AND 85 PSI PRESSURE PROTECTION FOR AIR HORN(S)		
413-002	STD U.S. FRONT BRAKE VALVE		
432-003	RELAY VALVE WITH 5-8 PSI CRACK PRESSURE, NO REAR PROPORTIONING VALVE		
480-088	WABCO SYSTEM SAVER HP WITH INTEGRAL AIR GOVERNOR AND HEATER		
479-012	AIR DRYER MOUNTED UNDER HOOD		
460-001	STEEL AIR BRAKE RESERVOIRS		
46A-023	(1) 1730 CUBIC INCH AIR HORN TANK, 85 PSI PRESSURE PROTECTED INLET WITH CHECK VALVE AND QUICK DISCONNECT FITTING	20	25
607-043	CLEAR FRAME RAILS 48 INCHES FROM BACK OF CAB INSIDE/OUTBOARD AND BELOW BOTH FRAME RAILS		
477-004	PULL CABLES ON ALL AIR RESERVOIR(S)		
Trailer Connections			
335-004	UPGRADED CHASSIS MULTIPLEXING UNIT		
32A-002	UPGRADED BULKHEAD MULTIPLEXING UNIT		
Wheelbase & Frame			
545-532	5325MM (210 INCH) WHEELBASE		
546-101	11/32X3-1/2X10-15/16 INCH STEEL FRAME (8.73MMX277.8MM/0.344X10.94 INCH) 120KSI	170	110
547-001	1/4 INCH (6.35MM) C-CHANNEL INNER FRAME REINFORCEMENT	150	370
552-040	1875MM (74 INCH) REAR FRAME OVERHANG		
55W-007	FRAME OVERHANG RANGE: 71 INCH TO 80 INCH	-30	120
AC8-99D	CALC'D BACK OF CAB TO REAR SUSP C/L (CA) : 144.09 in		
AE8-99D	CALCULATED EFFECTIVE BACK OF CAB TO REAR SUSPENSION C/L (CA) : 141.09 in		
AE4-99D	CALC'D FRAME LENGTH - OVERALL : 312.84 in		
FSS-0LH	CALCULATED FRAME SPACE LH SIDE : 109.38 in		
FSS-0RH	CALCULATED FRAME SPACE RH SIDE : 91.55 in		
553-001	SQUARE END OF FRAME		
587-003	REAR TOW HOOKS		10
550-001	FRONT CLOSING CROSSMEMBER		
559-003	LIGHTWEIGHT HEAVY DUTY ALUMINUM ENGINE CROSSMEMBER	-12	
561-001	STANDARD CROSSMEMBER BACK OF TRANSMISSION		
562-001	STANDARD MIDSHIP #1 CROSSMEMBER(S)		
572-001	STANDARD REARMOST CROSSMEMBER		
565-001	STANDARD SUSPENSION CROSSMEMBER		
Chassis Equipment			
556-997	OMIT FRONT BUMPER, CUSTOMER INSTALLED SPECIAL BUMPER, DOES NOT COMPLY WITH FMCSR 393.203	-60	
586-024	FENDER AND FRONT OF HOOD MOUNTED FRONT MUDFLAPS		



Data Code	Description	Weight Front	Weight Rear
551-007	GRADE 8 THREADED HEX HEADED FRAME FASTENERS		
489-032	FACTORY INSTALLED BENDIX SMARTIRE TPMS WITH WHEEL RIM MOUNTED SENSORS & STANDARD GAUGE MOUNTED IN DASH ON J1939 500K.	6	6
605-003	LEVEL FRAME RAILS (+/- 1%) WHEN CHASSIS IS LOADED TO FRONT AND REAR SUSPENSION RATINGS		
601-017	2D DXF/PDF VEHICLE DRAWING		
970-038	TANK BODY 0 TO 1500 GALLONS		

Fuel Tanks

204-215	50 GALLON/189 LITER SHORT RECTANGULAR ALUMINUM FUEL TANK - LH	20	
218-005	RECTANGULAR FUEL TANK(S)		
215-005	PLAIN ALUMINUM/PAINTED STEEL FUEL/HYDRAULIC TANK(S) WITH PAINTED BANDS		
212-007	FUEL TANK(S) FORWARD		
232-510	10 GALLONS ADDITIONAL FUEL		
664-004	POLISHED STAINLESS STEEL STEP FINISH		
205-001	FUEL TANK CAP(S)		
122-1H8	DAVCO 245 FUEL/WATER SEPARATOR WITH 12 VOLT HEAT AND WATER IN FUEL SENSOR	5	
216-020	EQUIFLO INBOARD FUEL SYSTEM		
202-016	HIGH TEMPERATURE REINFORCED NYLON FUEL LINE		
213-001	INSULATION FOR FUEL LINES	2	

Tires

093-994	MICHELIN XZE 12R22.5 16 PLY RADIAL FRONT TIRES	50	
094-0E3	MICHELIN XDS 12R22.5 16 PLY RADIAL REAR TIRES		156

Hubs

418-060	CONMET PRESET PLUS PREMIUM IRON FRONT HUBS		
450-060	CONMET PRESET PLUS PREMIUM IRON REAR HUBS		

Wheels

502-579	MAXION WHEELS 10041 22.5X9.00 10-HUB PILOT 5.25 INSET 5-HAND STEEL DISC FRONT WHEELS	66	
505-596	MAXION WHEELS 10047 22.5X9.00 10-HUB PILOT 5-HAND STEEL DISC REAR WHEELS		92
50W-001	BENDIX SMARTIRE TIRE PRESSURE MONITORING SYSTEM WHEEL/RIM MOUNTED SENSORS, ALL AXLES		8
496-011	FRONT WHEEL MOUNTING NUTS		
497-011	REAR WHEEL MOUNTING NUTS		
498-019	ALLIGATOR/V2B DUAL SEAL INFLATOR CAPS, FRONT AND REAR		

Cab Exterior



Data Code	Description	Weight Front	Weight Rear
829-071	106 INCH BBC FLAT ROOF ALUMINUM CONVENTIONAL CAB		
650-003	LEAF SPRING REAR CAB SUSPENSION		
705-012	CAB ROOF REINFORCEMENTS FOR ROOF MOUNTED COMPONENTS	2	
678-018	LH AND RH EXTERIOR GRAB HANDLES WITH SINGLE RUBBER INSERT		
646-023	HOOD MOUNTED CHROMED PLASTIC GRILLE		
65X-003	CHROME HOOD MOUNTED AIR INTAKE GRILLE		
644-004	FIBERGLASS HOOD		
690-002	TUNNEL/FIREWALL LINER		
727-1B0	DUAL 25 INCH ROUND STUTTER TONE HOOD MOUNTED AIR HORNS	8	
726-001	SINGLE ELECTRIC HORN		
728-002	DUAL HORN SHIELDS		
575-001	REAR LICENSE PLATE MOUNT END OF FRAME		
312-088	LED HEADLIGHT ASSEMBLY AND INCANDESCENT MARKER/TURN LAMP WITH CHROME BEZEL		
302-047	LED AERODYNAMIC MARKER LIGHTS		
311-001	DAYTIME RUNNING LIGHTS		
294-094	OMIT STOP/TAIL/BACKUP LIGHTS AND PROVIDE WIRING WITH SEPARATE STOP/TAIL WIRES TO 7 FEET BEYOND END OF FRAME		-5
300-015	STANDARD FRONT TURN SIGNAL LAMPS		
469-014	AUTOMATIC ON/OFF, ENGINE COMPARTMENT, HOOD ACTIVATED WORK LIGHT WITH MANUAL OVERRIDE	1	
744-1BC	DUAL WEST COAST BRIGHT FINISH HEATED MIRRORS WITH LH AND RH REMOTE		
797-001	DOOR MOUNTED MIRRORS		
796-001	102 INCH EQUIPMENT WIDTH		
743-204	LH AND RH 8 INCH BRIGHT FINISH CONVEX MIRRORS MOUNTED UNDER PRIMARY MIRRORS		
74A-001	RH DOWN VIEW MIRROR		
729-001	STANDARD SIDE/REAR REFLECTORS		
677-055	RH AFTERTREATMENT SYSTEM CAB ACCESS WITH POLISHED DIAMOND PLATE COVER		
768-043	63X14 INCH TINTED REAR WINDOW		
661-003	TINTED DOOR GLASS LH AND RH WITH TINTED NON-OPERATING WING WINDOWS		
654-003	MANUAL DOOR WINDOW REGULATORS		
663-013	1-PIECE SOLAR GREEN GLASS WINDSHIELD		
659-019	2 GALLON WINDSHIELD WASHER RESERVOIR WITHOUT FLUID LEVEL INDICATOR, FRAME MOUNTED		
Cab Interior			
707-1AK	OPAL GRAY VINYL INTERIOR		
706-013	MOLDED PLASTIC DOOR PANEL		
708-013	MOLDED PLASTIC DOOR PANEL		
772-006	BLACK MATS WITH SINGLE INSULATION		



Data Code	Description	Weight Front	Weight Rear
691-008	FORWARD ROOF MOUNTED CONSOLE WITH UPPER STORAGE COMPARTMENTS WITHOUT NETTING		
694-010	IN DASH STORAGE BIN		
742-007	(2) CUP HOLDERS LH AND RH DASH		
680-006	GRAY/CHARCOAL FLAT DASH		
860-004	SMART SWITCH EXPANSION MODULE		
700-002	HEATER, DEFROSTER AND AIR CONDITIONER		
701-001	STANDARD HVAC DUCTING		
703-005	MAIN HVAC CONTROLS WITH RECIRCULATION SWITCH		
170-019	STANDARD HEATER PLUMBING WITH BALL SHUTOFF VALVES		
130-041	VALEO HEAVY DUTY A/C REFRIGERANT COMPRESSOR		
702-002	BINARY CONTROL, R-134A		
739-033	STANDARD INSULATION		
285-013	SOLID-STATE CIRCUIT PROTECTION AND FUSES		
280-007	12V NEGATIVE GROUND ELECTRICAL SYSTEM		
324-011	DOME DOOR ACTIVATED LH AND RH, DUAL READING LIGHTS, FORWARD CAB ROOF		
657-001	DOOR LOCKS AND IGNITION SWITCH KEYED THE SAME		
78G-004	KEY QUANTITY OF 4		
655-001	CAB DOOR LATCHES WITH MANUAL DOOR LOCKS		
284-102	(2) DUAL 2.1 AMP USB CHARGERS IN DASH		
756-1E7	SEATS INC 911 UNIVERSAL SERIES HIGH BACK AIR SUSPENSION DRIVER SEAT WITH NFPA 1901-2009/2016 COMPLIANT SEAT SENSOR	50	
760-1F1	SEATS INC 911 UNIVERSAL SERIES HIGH BACK NON SUSPENSION PASSENGER SEAT WITH UNDERSEAT STORAGE AND NFPA 1901-2009/2016 COMPLIANT SEAT SENSOR	25	10
711-004	LH AND RH INTEGRAL DOOR PANEL ARMRESTS		
758-023	GRAY VINYL DRIVER SEAT COVER WITH GRAY CORDURA CLOTH BOLSTER AND HEADREST		
761-022	GRAY VINYL FRONT PASSENGER SEAT COVER WITH GRAY CORDURA CLOTH BOLSTER AND HEADREST		
763-105	NFPA 1901-2009 HIGH VISIBILITY ORANGE SEAT BELTS		
532-002	ADJUSTABLE TILT AND TELESCOPING STEERING COLUMN	10	
540-015	4-SPOKE 18 INCH (450MM) STEERING WHEEL		
765-002	DRIVER AND PASSENGER INTERIOR SUN VISORS		

Instruments & Controls

732-004	GRAY DRIVER INSTRUMENT PANEL		
734-004	GRAY CENTER INSTRUMENT PANEL		
87L-001	ENGINE REMOTE INTERFACE WITH PARK BRAKE INTERLOCK		
870-001	BLACK GAUGE BEZELS		



North Carolina Sheriff's Association



Data Code	Description	Weight Front	Weight Rear
486-001	LOW AIR PRESSURE INDICATOR LIGHT AND AUDIBLE ALARM		
840-002	2 INCH PRIMARY AND SECONDARY AIR PRESSURE GAUGES		
198-003	DASH MOUNTED AIR RESTRICTION INDICATOR WITH GRADUATIONS		
721-001	97 DB BACKUP ALARM		3
149-013	ELECTRONIC CRUISE CONTROL WITH SWITCHES IN LH SWITCH PANEL		
156-007	KEY OPERATED IGNITION SWITCH AND INTEGRAL START POSITION; 4 POSITION OFF/RUN/START/ACCESSORY		
811-042	ICU3S, 132X48 DISPLAY WITH DIAGNOSTICS, 28 LED WARNING LAMPS AND DATA LINKED		
160-038	HEAVY DUTY ONBOARD DIAGNOSTICS INTERFACE CONNECTOR LOCATED BELOW LH DASH		
844-001	2 INCH ELECTRIC FUEL GAUGE		
148-070	ENGINE REMOTE INTERFACE WITH PRESET FAST IDLE		
163-001	ENGINE REMOTE INTERFACE CONNECTOR AT BACK OF CAB		
856-001	ELECTRICAL ENGINE COOLANT TEMPERATURE GAUGE		
864-001	2 INCH TRANSMISSION OIL TEMPERATURE GAUGE		
830-017	ENGINE AND TRIP HOUR METERS INTEGRAL WITHIN DRIVER DISPLAY		
N 372-035	(1) DASH MOUNTED PTO SWITCH WITH INDICATOR LAMP	10	
49B-004	ELECTRONIC STABILITY CONTROL		
852-002	ELECTRIC ENGINE OIL PRESSURE GAUGE		
679-001	OVERHEAD INSTRUMENT PANEL		
746-135	AM/FM/WB WORLD TUNER RADIO WITH SIRIUSXM, BLUETOOTH, IPOD INTERFACE, USB AND AUXILIARY INPUTS, J1939	10	
747-001	DASH MOUNTED RADIO		
750-002	(2) RADIO SPEAKERS IN CAB		
753-001	AM/FM ANTENNA MOUNTED ON FORWARD LH ROOF		
748-001	POWER AND GROUND STUDS IN/UNDER DASH		
78C-003	INTEROPERABLE SDAR ANTENNA		
810-027	ELECTRONIC MPH SPEEDOMETER WITH SECONDARY KPH SCALE, WITHOUT ODOMETER		
817-001	STANDARD VEHICLE SPEED SENSOR		
812-001	ELECTRONIC 3000 RPM TACHOMETER		
162-002	IGNITION SWITCH CONTROLLED ENGINE STOP		
81Y-001	PRE-TRIP LAMP INSPECTION, ALL OUTPUTS FLASH, WITH SMART SWITCH		
264-028	(2) LH AND RH FOOT SWITCHES WITH DASH SWITCH FOR HORN BUTTON TO CONTROL AIR HORN, DEFAULT TO ELECTRIC <85 PSI		
836-015	DIGITAL VOLTAGE DISPLAY INTEGRAL WITH DRIVER DISPLAY		



Data Code	Description	Weight Front	Weight Rear
660-008	SINGLE ELECTRIC WINDSHIELD WIPER MOTOR WITH DELAY		
304-001	MARKER LIGHT SWITCH INTEGRAL WITH HEADLIGHT SWITCH		
882-018	ONE VALVE PARKING BRAKE SYSTEM WITH DASH VALVE CONTROL AUTONEUTRAL AND WARNING INDICATOR		
299-013	SELF CANCELING TURN SIGNAL SWITCH WITH DIMMER, WASHER/WIPER AND HAZARD IN HANDLE		
298-048	INTEGRAL ELECTRONIC TURN SIGNAL FLASHER WITH STOP LAMPS OVERRIDING HAZARD LAMPS		

Design

065-000	PAINT: ONE SOLID COLOR
---------	------------------------

Color

980-2L4	CAB COLOR A: L2225EY CANDY APPLE RED ELITE EY
986-020	BLACK, HIGH SOLIDS POLYURETHANE CHASSIS PAINT
962-802	FRONT WHEEL PAINT: 00767681EA BLACK ELITE SS
966-802	REAR WHEEL PAINT: 00767681EA BLACK ELITE SS
963-003	STANDARD E COAT/UNDERCOATING

Certification / Compliance

996-001	U.S. FMVSS CERTIFICATION, EXCEPT SALES CABS AND GLIDER KITS
---------	---

Raw Performance Data

AE8-99D	CALCULATED EFFECTIVE BACK OF CAB TO REAR SUSPENSION C/L (CA) : 141.09 in
---------	--

Sales Programs

NO SALES PROGRAMS HAVE BEEN SELECTED

TOTAL VEHICLE SUMMARY

Weight Summary

	Weight Front	Weight Rear	Total Weight
Factory Weight ⁺	7542 lbs	5083 lbs	12625 lbs
Total Weight ⁺	7542 lbs	5083 lbs	12625 lbs

(+) Weights shown are estimates only.

If weight is critical, contact Customer Application Engineering.

(***) All cost increases for major components (Engines, Transmissions, Axles, Front and Rear Tires) and government mandated requirements, tariffs, and raw material surcharges will be passed through and added to factory invoices.

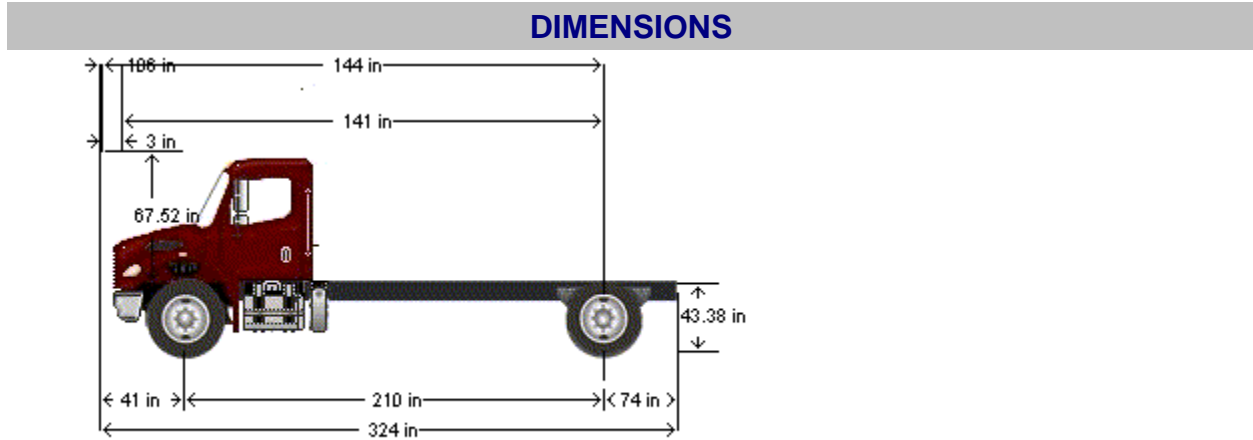

VEHICLE SPECIFICATIONS SUMMARY - DIMENSIONS

Model	M2106
Wheelbase (545)	5325MM (210 INCH) WHEELBASE
Rear Frame Overhang (552)	1875MM (74 INCH) REAR FRAME OVERHANG
Fifth Wheel (578)	NO FIFTH WHEEL
Mounting Location (577)	NO FIFTH WHEEL LOCATION
Maximum Forward Position (in)	0
Maximum Rearward Position (in)	0
Amount of Slide Travel (in)	0
Slide Increment (in)	0
Desired Slide Position (in)	0.0
Cab Size (829)	106 INCH BBC FLAT ROOF ALUMINUM CONVENTIONAL CAB
Sleeper (682)	NO SLEEPER BOX/SLEEPER CAB
Exhaust System (016)	RH OUTBOARD UNDER STEP MOUNTED HORIZONTAL AFTERTREATMENT SYSTEM ASSEMBLY WITH RH HORIZONTAL TAILPIPE EXITING FORWARD OF REAR TIRES

TABLE SUMMARY - DIMENSIONS

Dimensions	Inches
Bumper to Back of Cab (BBC)	106.3
Bumper to Centerline of Front Axle (BA)	40.7
Front Axle to Back of Cab (AC)	65.6
Min. Cab to Body Clearance (CB)	3.0
Back of Cab to Centerline of Rear Axle(s) (CA)	144.1
Effective Back of Cab to Centerline of Rear Axle(s) (Effective CA)	141.1
Back of Cab Protrusions (Exhaust/Intake) (CP)	2.0
Back of Cab Protrusions (Side Extenders/Trim Tab) (CP)	0.0
Back of Cab Protrusions (CNG Tank)	0.0
Back of Cab Clearance (CL)	3.0
Back of Cab to End of Frame	217.9
Cab Height (CH)	67.5
Wheelbase (WB)	209.6
Frame Overhang (OH)	73.8
Overall Frame Length	312.8
Overall Length (OAL)	324.2
Rear Axle Spacing	0.0
Unladen Frame Height at Centerline of Rear Axle	43.4

Performance calculations are estimates only. If performance calculations are critical, please contact Customer Application Engineering.



GVWR

VEHICLE SPECIFICATIONS SUMMARY - GVWR

Model		M2106
Cab Size (829)	106 INCH BBC FLAT ROOF ALUMINUM CONVENTIONAL CAB	
Expected Front Axle(s) Load (lbs)		14600.0
Expected Pusher Axle(s) Load (lbs)		0.0
Expected Rear Axle(s) Load (lbs)		26000.0
Expected Tag Axle(s) Load (lbs)		0.0
Expected GVW (lbs)		40600
Expected GCW (lbs)		0.0
Front Axle (400)	MFS-14-143A 14,700# FF1 71.5 INCH KPI/3.74 INCH DROP SINGLE FRONT AXLE	
Front Suspension (620)	14,600# TAPERLEAF FRONT SUSPENSION	
Front Hubs (418)	CONMET PRESET PLUS PREMIUM IRON FRONT HUBS	
Front Disc Wheels (502)	MAXION WHEELS 10041 22.5X9.00 10-HUB PILOT 5.25 INSET 5-HAND STEEL DISC FRONT WHEELS	
Front Tires (093)	MICHELIN XZE 12R22.5 16 PLY RADIAL FRONT TIRES	
Front Brakes (402)	MERITOR 16.5X5 Q+ CAST SPIDER CAM FRONT BRAKES, DOUBLE ANCHOR, FABRICATED SHOES	
Steering Gear (536)	TRW TAS-85 POWER STEERING	
Rear Axle (420)	RS-26-185 26,000# T-SERIES SINGLE REAR AXLE	
Rear Suspension (622)	27,000# FLAT LEAF SPRING REAR SUSPENSION WITH HELPER AND RADIUS ROD FOR	
FIRE/EMERGENCY SERVICE		
Rear Hubs (450)	CONMET PRESET PLUS PREMIUM IRON REAR HUBS	
Rear Disc Wheels (505)	MAXION WHEELS 10047 22.5X9.00 10-HUB PILOT 5-HAND STEEL DISC REAR WHEELS	
Rear Tires (094)	MICHELIN XDS 12R22.5 16 PLY RADIAL REAR TIRES	
Rear Brakes (423)	MERITOR 16.5X7 P CAST SPIDER CAM REAR BRAKES, DOUBLE ANCHOR, CAST SHOES	
Pusher / Tag Axle (443)	NO PUSHER OR TAG AXLE	
Pusher / Tag Suspension (626)	NO PUSHER OR TAG SUSPENSION	
Pusher / Tag Hubs (449)	NO PUSHER OR TAG HUBS	
Pusher/Tag Disc Wheels (509)	NO PUSHER/TAG DISC WHEELS	
Pusher / Tag Tires (095)	NO PUSHER/TAG TIRES	
Pusher / Tag Brakes (456)	NO PUSHER/TAG BRAKES	

TABLE SUMMARY - GVWR

	Front	Rear
Axle Component Weight Ratings		
Axles	14700	26000
Suspension	14600	27000
Hubs	14700	26000
Brakes	14700	27000
Wheels	20000	40000
Tires	14780	27120
Power Steering	18000	N/A
GAWR (per axle)	14600	26000
GAWR (per axle system)	14600	26000
Expected Load (per axle system)	14600	26000
GVWR due to Frame	90000	
GVWR due to Transmission	300000	
Vehicle GVWR Summary		
Calculated GVWR	40600	
Expected GVWR	40600	
All weights displayed in pounds		

Performance calculations are estimates only. If performance calculations are critical, please contact Customer Application Engineering.

UNLADEN FRAME HEIGHT

Unladen Height	Requested	Calculated
Tow Hitch (in)	0.00 to 0.00	32.80
Frame (in)	N/A	43.40

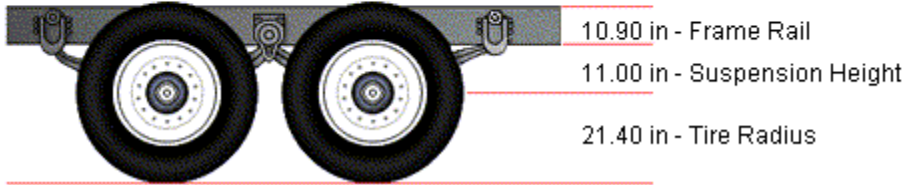

VEHICLE SPECIFICATIONS SUMMARY - UNLADEN FRAME HEIGHT

Model	M2106
Cab Size (829)	106 INCH BBC FLAT ROOF ALUMINUM CONVENTIONAL CAB
Frame Rails (546)	11/32X3-1/2X10-15/16 INCH STEEL FRAME (8.73MMX277.8MM/0.344X10.94 INCH) 120KSI(546)
Web Height (in)	10.9375
Flange Thickness (in)	0.34375
Rear Suspension (622)	27,000# FLAT LEAF SPRING REAR SUSPENSION WITH HELPER AND RADIUS ROD FOR
FIRE/EMERGENCY SERVICE	
Rear Suspension Ride Height (621)	SPRING SUSPENSION - 1.50" AXLE SPACER
Axle C/L to Bottom of Frame (in)	11.046
Rear Tires (094)	MICHELIN XDS 12R22.5 16 PLY RADIAL REAR TIRES
Unladen Radius (in)	21.4
Fifth Wheel (578)	NO FIFTH WHEEL
Requested Min Height (in)	0.0
Requested Max Height (in)	1
Fifth Wheel Leg Height (582)	NO FIFTH WHEEL LEG HEIGHT
Rear Tow Device (587)	REAR TOW HOOKS
Requested Min Height (in)	0.0
Requested Max Height (in)	0.0

Performance calculations are estimates only. If performance calculations are critical, please contact Customer Application Engineering.



FRAME RBM

VEHICLE SPECIFICATIONS SUMMARY - FRAME RBM

Wheelbase (545)	5325MM (210 INCH) WHEELBASE
Frame Rails (546)	11/32X3-1/2X10-15/16 INCH STEEL FRAME (8.73MMX277.8MM/0.344X10.94 INCH) 120KSI(546)
Yield Strength (psi)	120000
Section Modulus (per rail) (cu in)	16.979
RBM (per rail) (lbf-in)	2037600
Inner Frame Reinforcement (547)	1/4 INCH (6.35MM) C-CHANNEL INNER FRAME REINFORCEMENT
Outer Frame Reinforcement (548)	NO OUTER FRAME REINFORCEMENT

TABLE SUMMARY - FRAME RBM

Item	Description / Value
Wheelbase	5325MM (210 INCH) WHEELBASE
Frame	11/32X3-1/2X10-15/16 INCH STEEL FRAME (8.73MMX277.8MM/0.344X10.94 INCH) 120KSI
Inner Frame Reinforcement	1/4 INCH (6.35MM) C-CHANNEL INNER FRAME REINFORCEMENT
Outer Frame Reinforcement	NO OUTER FRAME REINFORCEMENT
Yield Strength (psi)	120000
Section Modulus - per rail (cu. in.)	26.80
Frame RBM - per rail (lbf-in)	3217200

Performance calculations are estimates only. If performance calculations are critical, please contact Customer Application Engineering.



SEAT BELT CLARIFICATION

Red seat belts will be provided if available from the chassis manufacturer.

WHEEL TRIM KITS

Wheel trim kits consisting of stainless steel baby moons, high hats and lug nut covers will be installed on the front and rear axles of the single rear axle chassis.

FUEL TANK TREAD PLATE

The step type fuel tank will be overlaid with polished aluminum tread plate. This will include the top, front and both ends. Step areas will be provided for access to the cab. Step areas will be fabricated from Alcoa "No-Slip" tread plate.

BATTERY BOX TREAD PLATE

The battery box will be overlaid with polished aluminum tread plate. The cover of this box will be easily removable for inspection of the batteries.

RIGHT SIDE CAB STEP AREA TREAD PLATE

The right side cab step area will be overlaid with polished aluminum tread plate. A single cab entry step, level with the right side running board will be furnished. Step areas will be fabricated from Alcoa "No-Slip" tread plate.

LEFT SIDE CAB STEP AREA TREAD PLATE

The left side cab step area will be overlaid with polished aluminum tread plate. A single cab entry step, level with the left side running board will be furnished. Step areas will be fabricated from Alcoa "No-Slip" tread plate.

CENTER CONSOLE

A center console fabricated from 1/8" aluminum will be furnished and will be located between the driver and officer's seats.

The forward area of the console will have a mounting surface for emergency lighting switch panels and/or electronic siren control boxes within reach of the driver or officer. In addition, the console will be equipped with two (2) map/notebook storage pockets at the rear of the console.

The console will be finished with a textured gray paint to match the interior color of the cab.

ANTENNA INSTALLATION

One (1) antenna mounting base(s) model #MATM with 17' of coaxial cable will be provided and installed on the cab roof. The attached antenna wire(s) will be run to the center console.

The Fire Department is responsible to have the correct antenna whip installed once the apparatus is delivered.

CAB STEP LIGHTS

TecNiq E-03 step lights will be provided, one (1) near each cab door to illuminate the cab stepping surfaces. The step lights will be mounted in a convenient location so as to provide appropriate illumination to the cab stepping surfaces. The step lights will automatically activate when the exit doors are opened, parking brake is applied, and marker lights are active.



AUXILIARY AIR MANIFOLD

All auxiliary air devices on the commercial chassis will be fed from a common manifold. The common manifold will be installed at an accessible location near the chassis air tanks. The manifold will be fed by a 3/8" synflex airline plumbed from the primary air tank using a pressure protection valve. Unused ports will be closed off using an appropriately sized plug.

3M REFLECTIVE CAB DOOR MATERIAL - RED/WHITE

There will be 3M Brand reflective alternating Red/White striping material with the FES logo installed on the inside of the driver and officer side cab doors.

20" STAINLESS STEEL FRONT BUMPER EXTENSION

A 12" high, 20" bright finish stainless steel front bumper extension will be provided. The bumper will be a wrapped design to match the contour of the front cab sheet.

ALUMINUM TREADPLATE GRAVEL SHIELD

A polished aluminum tread plate (3/16") gravel shield with end caps will be installed on the front bumper extension.

The polished aluminum tread plate gravel shield will terminate under the top bumper flange.

STORAGE WELL - CENTER

One (1) storage well constructed of 1/8" aluminum will be installed in the gravel shield. This storage well will be center mounted between the chassis frame rails. The bottom of the storage well will have a minimum of four (4) drain holes.

The center front bumper hose well will be furnished with Velcro straps to secure the hose stored in the well. The straps will be attached to each side of the hose well with stainless steel footman loops.

CENTER WELL - HOSE CAPACITY

The center storage well will have the desired capacity of:

- 150' of 1 3/4" hose

FRONT TOW HOOKS

Two (2) front painted tow hooks will be fastened directly to the frame, below the front bumper. The tow hooks will be fastened with grade 8 bolts and nuts.

PUMP SHIFT CONTROL

The pump shift control and pump engaged indicator light will be mounted in the driver's lower left panel.



**** CHASSIS/BODY ELECTRICAL & ACCESSORIES ****

COMMERCIAL CHASSIS ELECTRICAL SYSTEM

The commercial chassis electrical system will be provided as furnished by the original manufacturer. A customized interface will be provided and designed, so as not to disturb any of the required chassis functions. The necessary interfaces will only be provided in areas where load management is allowed or with accessory components provided on the chassis.

12 VOLT ELECTRICAL SYSTEM TESTING

The apparatus low voltage electrical system will be tested and certified by the manufacturer. The certification will be provided with the apparatus. All tests will be performed with air temperature between 0°F and 100°F.

The following three (3) tests will be performed in order. Before each test, the batteries will be fully charged.

TEST #1-RESERVE CAPACITY TEST

The engine will be started and kept running until the engine and engine compartment temperatures are stabilized at normal operating temperatures and the battery system is fully charged. The engine will be shut off and the minimum continuous electrical load will be activated for 10 minutes. All electrical loads will be turned off prior to attempting to restart the engine. The battery system will then be capable of restarting the engine. Failure to restart the engine will be considered a test failure.

TEST #2-ALTERNATOR PERFORMANCE TEST AT IDLE

The minimum continuous electrical load will be activated with the engine running at idle speed. The engine temperature will be stabilized at normal operating temperature. The battery system will be tested to detect the presence of battery discharge current. The detection of battery discharge current will be considered a test failure.

TEST #3-ALTERNATOR PERFORMANCE TEST AT FULL LOAD

The total continuous electrical load will be activated with the engine running up to the engine manufacturers governed speed. The test duration will be a minimum of 2 hours. Activation of the load management system will be permitted during this test. However, an alarm sounded due to excessive battery discharge, as detected by the system, or a system voltage of less than 11.7 volts DC for a 12 volt system, for more than 120 seconds, will be considered a test failure.



LOW VOLTAGE ALARM TEST

Following completion of the preceding tests, the engine will be shut off. The total continuous electrical load will be activated and will continue to be applied until the excessive battery discharge alarm is activated.

The battery voltage will be measured at the battery terminals. With the load still applied, a reading of less than 11.7 volts will be considered a test failure. The battery system will then be able to restart the engine.

At time of delivery, documentation will be provided with the following information:

- Documentation of the electrical system performance test
- A written load analysis of the following;
- Nameplate rating of the alternator
- Alternator rating at idle while meeting the minimum continuous electrical load
- Each component load comprising the minimum continuous electrical load.
- Additional loads that, when added to the minimum continuous load, determine the total connected load.
- Each individual intermittent load.

LOAD MANAGEMENT SYSTEM

An "Intelligent" load management system will be provided. The load management system will be capable of offering load sequencing, load shedding, fast idle control, low voltage warning, scene mode operation and response mode operation.

The load management will have a digital display to indicate system voltage in normal operation mode and also indicate the output configuration during programming mode.

The load management will also be protected against reverse polarity and shorted outputs and be enclosed in a metal enclosure to enhance EMI/RFI protection.

VOLTAGE MONITOR SYSTEM

A voltage monitoring system will be provided to indicate the status of the battery system connected to the vehicle's electrical load. The system will provide visual and audible warning when the system voltage is below or above optimum levels.

The alarm will activate if the system falls below 11.8 volts DC for more than two (2) minutes.



ELECTRICAL HARNESS REQUIREMENT

To ensure dependability, all 12-volt wiring harnesses installed by the manufacturer will conform to the following specifications:

- SAE J 1128 - Low tension primary cable
- SAE J 1292 - Automobile, truck, truck-tractor, trailer and motor coach wiring
- SAE J 163 - Low tension wiring and cable terminals and splice clips
- SAE J 2202 - Heavy duty wiring systems for on-highway trucks
- NFPA 1901 - Standard for automotive fire apparatus
- FMVSS 302 - Flammability of interior materials for passenger cars, multipurpose passenger vehicles, trucks and buses
- SAE J 1939 - Serial communications protocol
- SAE J 2030 - Heavy-duty electrical connector performance standard
- SAE J 2223 - Connections for on board vehicle electrical wiring harnesses
- NEC - National Electrical Code
- SAE J 561 - Electrical terminals - Eyelet and spade type
- SAE J 928 - Electrical terminals - Pin and receptacle type A.

For increased reliability and harness integrity, harnesses will be routed throughout the cab and chassis in a manner which allows the harnessing to be laid into its mounting location. Routing of harnessing which requires pulling of wires through tubes is never allowed at the manufacturer.

Wiring will be run in loom or conduit where exposed and have grommets or other edge protection where wires pass through metal. Wire colors will be integral to each wire insulator and run the entire length of each wire. Harnessing containing multiple wires and uses a single wire color for all wires will not be allowed. Function and number codes will be continuously imprinted on all wiring harness conductors at 3.00" intervals. All wiring installed between the cab and into doors will be protected by a wire conduit to protect the wiring. Exterior exposed wire connectors will be positive locking, and environmentally sealed to withstand elements such as temperature extremes, moisture and automotive fluids. Electrical wiring and equipment will be installed utilizing the following guidelines:

- All holes made in the roof will be caulked with silicon. Large fender washers, liberally caulked, will be used when fastening equipment to the underside of the cab roof.
- Any electrical component that is installed in an exposed area will be mounted in a manner that will not allow moisture to accumulate in it. Exposed area will be defined as any location outside of the cab or body.
- For low cost of ownership, electrical components designed to be removed for maintenance will be quickly accessible. For ease of use, a coil of wire will be provided behind the appliance to allow them to be pulled away from the mounting area for inspection and service work.
- Corrosion preventative compound will be applied to non-waterproof electrical connectors located outside of the cab or body. All non-waterproof connections will require this compound in the plug to prevent corrosion and for easy separation of the plug.
- Any lights containing non-waterproof sockets in a weather-exposed area will have corrosion preventative compound added to the socket terminal area.
- All electrical terminals in exposed areas will have protective coating applied completely over the metal portion of the terminal.
- Rubber coated metal clamps will be used to support wire harnessing and battery cables routed along the chassis frame rails.
- Heat shields will be used to protect harnessing in areas where high temperatures exist. Harnessing passing near the engine exhaust will be protected by a heat shield.
- Cab and crew cab harnessing will not be routed through enclosed metal tubing. Dedicated wire routing channels will be used to protect harnessing therefore improving the overall integrity of the vehicle electrical system. The design of the cab will allow for easy routing of additional wiring and easy access to existing wiring.



ELECTRICAL HARNESS REQUIREMENT, CONT'D.

- All standard wiring entering or exiting the cab will be routed through sealed bulkhead connectors to protect against water intrusion into the cab.

BATTERY CABLE INSTALLATION

All 12-volt battery cables and battery cable harnessing installed by the apparatus manufacturer will conform to the following requirements:

- SAE J 1127 - Battery Cable
- SAE J 561 - Electrical terminals, eyelets and spade type
- SAE J 562 - Nonmetallic loom
- SAE J 836 A - Automotive metallurgical joining
- SAE J 1292 - Automotive truck, truck-tractor, trailer and motor coach wiring
- NFPA 1901 - Standard for automotive fire apparatus.

Battery cables and battery cable harnessing will be installed utilizing the following guidelines:

- Splices will not be allowed on battery cables or battery cable harnesses.
- For ease of identification and simplified use, battery cables will be color coded. All positive battery cables will be marked red in color. All negative battery cables will be black in color.
- For ease of identification, all positive battery cable isolated studs throughout the cab and chassis will be red in color.
- For increased reliability and reduced maintenance, all electrical buss bars located on the exterior of the apparatus will be coated to prevent corrosion.
- An operational test will be conducted to ensure that any equipment that is permanently attached to the electrical system is properly connected and in working order.

12 VOLT BATTERY CHARGING RECEPTACLE

A 12 volt, polarized battery charging receptacle, with a weather tight cover, will be provided. This receptacle will allow a purchaser supplied external 12 volt battery charger to be utilized. A label will be provided indicating voltage and amperage ratings.

SHORELINE POWER INLET PLATE

A shoreline power receptacle information plate will be permanently affixed at or near the power inlet. The plate will indicate the following:

- Type of Line Voltage
- Current Rating in Amps Power Inlet Type (DC or AC).

The shoreline receptacle will be located in the driver's cab step well in a pre-determined location by FES.



EMERGENCY/AUXILIARY SWITCHES

The commercial cab will be equipped with an area for component switching within easy reach of the driver and or officer. This switch package will separate the emergency/auxiliary electrical functions from the regular chassis functions. A minimum of four (4) programmable switches with integral indicator lights will be provided.

The four (4) switches will be green backlit and located in the cab near the driver for warning lights and auxiliary controls.

All switches, (other than the master switch), will have switch function labeling and an integral indicator light.

"DO NOT MOVE APPARATUS" WARNING LIGHT WITH AUDIBLE ALARM

A Truck-Lite 2.5" round, red flashing warning light with an audible alarm, will be functionally located in the cab and will be activated automatically whenever the apparatus parking brake is not fully engaged and of the following conditions exist:

- Any driver, passenger or equipment compartment door is not closed
- Any ladder or equipment rack is not in the stowed position
- Stabilizer system is not in its stowed position
- Powered light tower is not stowed
- Any other device permanently attached to the apparatus is open, extended or deployed in a manner that is likely to cause damage to the apparatus if the apparatus is moved

This light will be labeled "Do Not Move Apparatus When Light Is On."

BLUE SEA FUSE BLOCK - 6 CIRCUIT IN CENTER CONSOLE

A Blue Sea 5025B, 6 circuit fuse block will be installed. This block has a maximum amperage of 60 Amps per block and 30 Amps per circuit.

VISION & CAMERA SYSTEM EQUIPMENT

ASA VOYAGER REAR CAMERA SYSTEM

An ASA Voyager Heavy Duty Observation System model #VOS74WPCL1B will be provided and installed.

This Observation System includes a Voyager 7" quad view waterproof digital color TFT LCD monitor, VOM74WP, that has the capability of single images, split-screen or quad view modes. The monitor will be mounted to allow the driver to visually see the rear of the apparatus while in the cab.

One (1) waterproof rear view CMOS color camera with built in microphone, VCMS155B, will be provided and surface mounted on the rear of the apparatus body. The rear view camera will be wired to automatically activate when the chassis transmission is placed in reverse.

The monitor for the rear vision system will be mounted ceiling of the cab in easy view of the driver.



****** BODY ELECTRICAL SYSTEM ******

12 VOLT BODY ELECTRICAL SYSTEM

All electrical lines in the body will be protected by automatic circuit breakers, conveniently located to permit ease of service. Flashers, heavy solenoids and other major electrical controls will be located in a central area near the circuit breakers.

All lines will be color and function coded every 3", easy to identify, oversized for the intended loads and installed in accordance with a detailed diagram. A complete wiring diagram will be supplied with the apparatus.

Wiring will be carefully protected from weather elements and snagging. Heavy duty loom will be used for the entire length. Grommets will be utilized where wiring passes through panels.

In order to minimize the risk of heat damage, wires run in the engine compartment area will be carefully installed and suitably protected by the installation of heat resistant shielded loom.

All electrical equipment will be installed to conform to the latest federal standards as outlined in NFPA 1901.

DOT MARKER LIGHTS AND REFLECTORS

Cab marker lights and signaling devices will be as provided on the commercial chassis cab from the original chassis manufacturer. FMVSS reflectors will be provided as required.

Two (2) TecNiq model SL15-AC00-1 amber LED with clear lens clearance side marker lights will be provided on the apparatus front upper body corner, one (1) each side.

Two (2) Optronics Model STL75AB oval yellow LED side turn signal/marker light will be recessed mounted in a black grommet on the apparatus lower side, forward of rear axle, one (1) each side if the apparatus is 30' long or longer.

Two (2) Optronics model MCL82RDB low profile, flush mount rectangular red LED marker lights with reflex lens will be provided at the lower side rear, one (1) each side.

Two (2) TecNiq model SL15-RC00-1 red LED with clear lens clearance side marker lights will be provided on the apparatus rear upper, one (1) each side at the outermost practical location.

Three (3) Optronics model MCL82RDB low profile, flush mount rectangular red LED marker lights with reflex lens will be provided on the apparatus rear center.

LED LICENSE PLATE LIGHT - REAR

One (1) TecNiq model L10 LED license plate light will be provided above the mounting position of the license plate. The light will be clear in color and will have a chrome finish.



WHELEN BRAKE/TAIL/TURN AND BACK UP LIGHTS

Two (2) Whelen M6 Series Model # M6BTT brake/tail/turn lights will be provided. The M6BTT configuration will consist of 72 red 5mm Super-LEDs® and a red non-optic polycarbonate lens. The M6BTT will include two Scan-Lock™ flash patterns of Steady (Brake) Default and SignalAlert™ Steady.

Two (2) Whelen M6 Series Model # M6T turn arrow light will be provided. The M6T configuration will consist of 64 amber 5mm Super-LEDs® and an amber non-optic polycarbonate lens. The turn arrow, with the aid of two screws, will have the ability to be installed as a surface mount warning light. The M6T will include two Scan-Lock flash patterns of Steady (Brake) Default and SignalAlert™ Steady.

Two (2) Whelen M6 Series Model # M6BUW back-up light will be provided. The steady burn back-up light will incorporate Linear Super-LED® and technology. The M6BUW configuration will consist of 12 clear Super-LEDs and a clear optic polycarbonate lens. The M6BUW will utilize optic collimators, a metalized reflector, and optic lens for maximum illumination.

The encapsulated assembly will be resistant to water, moisture, dust, and other environmental conditions. The hard coated lens will provide extended life/luster protection against UV and chemical stresses. The light engine will be installed at the rear of the unit and be vacuum tested to ensure proper sealing. The PC board will be conformal coated for additional protection.

The brake/tail/turn and backup lights will meet SAE specifications J1398, J585, J1395, J586, and J1330. The M6BTT is covered by a five year factory warranty.

Two (2) Whelen M6 series chrome flanges model # M6FCV3 will be provided.

TECNIQ EON-3 LED BODY STEP LIGHTS

Two (2) polished stainless steel, TecNiq Eon 3-LED horizontal surface mounted body step lights will be provided. The lights will automatically activate when the exit doors are opened and marker lights are activated. Step lights will be located to properly illuminate all body access steps and walkway areas and will include a mounting gasket to provide a watertight seal.

TECNIQ EON-3 LED DUNNAGE AREA LIGHTING

Two (2) stainless steel, TecNiq Eon 3-LED horizontal surface mounted lights will be provided in the dunnage area to provide adequate illumination of this area. These lights will be activated with the engagement parking brake.

TECNIQ E41 LED HOSE BED LIGHTS

One (1) TecNiq E41 Series LED surface mounted strip lights will be mounted in the hose bed on the front wall to illuminate the hose bed area.

HOSE BED WORK LIGHT - SWITCH

The hose bed work light will have a protected 12-volt switch at the rear body panel. The switch will be labeled "HOSE BED WORK LIGHTS".

LIGHT HOUSING FOR HOSEBED LIGHT SWITCH

A Cast Products light switch housing with hinged flange and polished lid will be provided for the hosebed light switch.



TECNIQ E18 LED PUMP ENCLOSURE WORK LIGHTS

Two (2) TecNiq model #E18 lights will be provided inside the pump enclosure providing 800 lumens each. Each light will have their own independent switch incorporated into the light head.

LIGHT HOUSING FOR PUMP PANEL LIGHT SWITCH

A Cast Products light switch housing with hinged flange and polished lid will be provided for the pump panel light switch.

WHELEN M9 SERIES LED SCENE LIGHTS - REAR OF BODY

Two (2) Whelen M9LZC super LED scene lights will be provided, one on each side of the rear body panel in a chrome plated flange. Each light will draw 6 amps and generate 6,500 lumens. The scene lights will be wired through the load management system.

WHELEN M9 SERIES LED SCENE LIGHTS - DRIVER SIDE OF BODY

Two (2) Whelen M9LZC super LED scene lights will be provided. The scene lights will be installed one rearward and one forward on the driver side of the body in a chrome plated flange. Each light will draw 6 amps and generate 6,500 lumens. The scene lights will be wired through the load management system.

WHELEN M9 SERIES LED SCENE LIGHTS - OFFICER SIDE OF BODY

Two (2) Whelen M9LZC super LED scene lights will be provided. The scene lights will be installed one rearward and one forward on the officer side of the body in a chrome plated flange. Each light will draw 6 amps and generate 6,500 lumens. The scene lights will be wired through the load management system.

REAR OF BODY SCENE LIGHT SWITCHING - IN CAB

A switch will be provided in the cab warning light switch console to turn the rear of body scene lights on and off.

DRIVER SIDE OF BODY SCENE LIGHT SWITCHING - IN CAB

A switch will be provided in the cab warning light switch console to turn the driver side of body scene lights on and off.

OFFICER SIDE OF BODY SCENE LIGHT SWITCHING - IN CAB

A switch will be provided in the cab warning light switch console to turn the officer side of body scene lights on and off.

LOW PROFILE - BROW LIGHT - 19,800 LUMENS LED - ABOVE WINDSHIELD

One (1) 46" HiViz LED "FireTech" brow light model #FT-B-46-(B or W) will be furnished and installed.

The light will be mounted using FireTech's rail mounting foot and can be securely attached to the cab on the top edge of the windshield every 12 inches preventing the housing from flexing which would cause moisture intrusion. The housing will be made from a solid billet of aluminum which offers superior structural rigidity and thermal dissipation.

The brow light will have thirty-six (36) LEDs operating on three (3) circuits that give you a combination of long distance spot beam with multiple flood beams. The brow light be capable of producing 19,000 lumens of light. The light will feature a lifetime warranty.



LIGHT ABOVE WINDSHIELD SWITCHING - CAB

Three (3) switches will be provided in the cab warning light switch console to control the individual lighting circuits of the HiViz FireTech LED brow light.

TECNIQ E10 LED GROUND LIGHTS - BELOW CAB DOORS

One (1) TecNiq LED, 6" long ground light with stainless steel mounting bracket, will be provided under each side cab door entrance step, two (2) total.

Each light will illuminate an area at a minimum 30" outward from the edge of the vehicle.

TECNIQ E10 LED GROUND LIGHTS - BELOW PUMP PANEL

One (1) TecNiq LED, 6" long ground light with stainless steel mounting bracket, will be provided under each side pump panel running board, two (2) total.

TECNIQ E10 LED GROUND LIGHTS - BELOW REAR BODY CORNERS

One (1) TecNiq LED, 6" long ground light with stainless steel mounting bracket, will be provided under each rear body corner, two (2) total.

GROUND LIGHT SWITCHING - ENGAGE WITH PARKING BRAKE

The cab and body ground lights will activate by engaging the parking brake.

COMPARTMENT LIGHT ACTIVATION

Compartment lighting will be switched from an integral switch as provided by the roll up door manufacturer.

AMDOR LUMA BAR COMPARTMENT LIGHTS - LED

Seven (7) compartments will be equipped with 62" AMDOR Luma Bar Standalone White LED light fixtures mounted one each side of the forward (and rear) vertical door frame.



NFPA AUDIBLE AND LIGHTING WARNING PACKAGE

The following warning light package will include all of the minimum warning light and actuation requirements for the current revision of NPFA 1901 Fire Apparatus Standard. The lighting as specified will meet the requirements for both "Clearing Right of Way" and "Blocking Right of Way" which includes disabling all white warning lights when the apparatus is in "Blocking Right of Way" mode.

LIGHT PACKAGE ACTUATION CONTROLS

The entire warning light package will be actuated with a single warning light switch located on the cab switch panel. The wiring for the warning light package will engage all of the lights required for "Clearing Right of Way" mode when the vehicle parking brake is not engaged. An automatic control system will be provided to switch the warning lights to the "Blocking Right of Way" mode when the vehicle parking brake is engaged.

WARNING LIGHT FLASH PATTERN

All of the perimeter warning lights will be set to an NFPA compliant flash pattern by the apparatus manufacturer.

UPPER LEVEL LIGHTING - WHELEN

NFPA ZONE A, UPPER

A Whelen #JE0NFPA "Justice", 62" LED cab roof warning light bar will be furnished and rigidly mounted on top of the cab roof.

The light bar will be equipped with the following:

- Clear Lenses
- Four Corner Red Linear 6 LEDs
- Seven Red Forward Facing CON 3 LEDs
- Two White Forward Facing CON 3 LEDs.

If equipped, the forward facing white lights will be automatically disabled for the "Blocking Right of Way" mode.

NFPA ZONE C, UPPER

Two (2) Whelen M9 Series Model # M9RC warning lights will be furnished and mounted one (1) each side on the upper rear face of the body, facing rear. The warning light shall incorporate Linear Super-LED® and Smart LED® technology.

Each light head will be equipped with red LED lights and clear lenses.

The lights will be installed with a chrome plated mounting flange, M9FC.

NFPA ZONES B & D REAR, UPPER

Two (2) Whelen M9 Series Model # M9RC warning lights will be furnished and mounted one (1) each side on the upper side face, towards the rear of the body, facing to each side of the unit.

Each light head will be equipped with red LED lights and clear lenses.

The lights will be installed with a chrome plated mounting flange, M9FC.



NFPA ZONES B & D FRONT, UPPER

Two (2) Whelen M9 Series Model # M9RC warning lights will be furnished and mounted one (1) each side on the upper side face, towards the front of the body, facing to each side of the unit.

Each light head will be equipped with red LED lights and clear lenses.

The lights will be installed with a chrome plated mounting flange, M9FC.

LOWER LEVEL LIGHTING - WHELEN

NFPA ZONES A, LOWER

Two (2) Whelen M6 Series Model # M6RC warning lights will be furnished and mounted one (1) each side.

Each light head will be equipped with red LED lights and clear lenses.

The lights will be installed with a chrome plated mounting flange, M6FC.

The lower zone A warning lights will be mounted in the commercial chassis grille no higher than 62" from ground level.

NFPA ZONE C, LOWER

Two (2) Whelen M6 Series Model # M6RC warning lights will be furnished and installed one (1) each side directly below the DOT stop, tail, turn and backup lights.

Each light head will be equipped with red LED lights and clear lenses.

The lights will be installed with a chrome plated mounting flange, M6FC.

NFPA ZONES B & D FRONT, LOWER

Two (2) Whelen M6 Series Model # M6RC warning lights will be furnished and installed one (1) each side.

Each light head will be equipped with red LED lights and clear lenses.

The lights will be installed with a chrome plated mounting flange, M6FC.

The lower zone B & D warning lights will be mounted on the sides of the commercial chassis hood at or forward of the centerline of the front axle. The light will be mounted no higher than 62" from ground level.

NFPA ZONES B & D MIDSHIP, LOWER

Two (2) Whelen M6 Series Model # M6RC warning lights will be furnished and installed one (1) each side.

Each light head will be equipped with red LED lights and clear lenses.

The lights will be installed with a chrome plated mounting flange, M6FC.



NFPA ZONES B & D REAR, LOWER

Two (2) Whelen M6 Series Model # M6RC warning lights will be furnished and installed one (1) each side.

Each light head will be equipped with red LED lights and clear lenses.

The lights will be installed with a chrome plated mounting flange, M6FC.

WARNING LIGHT SYSTEM CERTIFICATION

The warning light system(s) specified above will not exceed a combined total amperage draw of 45 AMPS with all lights activated in either the "Clearing Right of Way" or the "Blocking Right of Way" mode.

The warning light system(s) will be certified by the light system manufacturer(s), to meet all of the requirements in the current revision of the NFPA 1901 Fire Apparatus Standard as noted in the General Requirements section of these specifications. The NFPA required "Certificate of Compliance" will be provided with the completed apparatus.

Any large truck as defined by NFPA will have the lower zone warning lights mounted no higher than 62" to the optical center of the warning light from ground level.



***** AUDIBLE WARNING EQUIPMENT *****

BACK-UP ALARM

A 97 dB(A) Whelen back-up alarm, will be provided and installed at the rear of the apparatus under the tailboard. The back-up alarm will activate automatically when the transmission is placed in reverse gear and the ignition is "on".

ELECTRONIC SIREN

One (1) Whelen Siren Amplifier model # 295SLSA1 will be provided. The siren amplifier will incorporate a 12V/200W siren installed on an aluminum alloy chassis covered by a black polycarbonate powder coated housing for maximum protection. The 295SLSA1 will have the ability for either 100 or 200 watt output. The operating controls will consist of a power switch, manual button, PA volume switch, horn button, and rotary switch.

The siren amplifier will have a "Siren in Use" icon driver and adjustable preset repeat radio volume. The 295SLSA1 will have a "Park Kill" feature that disables the siren when the vehicle is in park. The PTT (push to talk) switch on the microphone will override all siren functions. The 295SLSA1 will have a combination On/Off and horn ring transfer switch with Bi-polarity horn/ring activation control. The 295SLSA1 will have SI Test® capability to perform a complete diagnostic silent test of amplifier and speaker(s). The siren amplifier will have a quick disconnect plug.

The electronic siren and speaker will meet the NFPA required SAE certification to ensure compatibility between the siren and speaker.

ELECTRONIC SIREN SPEAKER - DRIVER'S SIDE OF FRONT BUMPER

One (1) Whelen, model # SA315P composite black siren speaker, will be provided, recessed on the driver's side of the front bumper and wired to the electronic siren

FEDERAL Q2B MECHANICAL SIREN - DRIVER'S SIDE PEDESTAL MOUNTED

One (1) Federal Model #Q2B mechanical siren will be provided to provide audible warning.

The Federal Signal Q2B mechanical siren will be pedestal mounted on top of the extended bumper on the driver's side. The siren will be equipped with a Federal Signal chrome housing and pedestal.

Q2B SIREN CONTROL

Two (2) floor mounted foot switches will be provided, one (1) for the officer and one (1) for the driver. A siren brake button will be provided near the driver's position.

FEDERAL Q2B SIREN INTERLOCK

The Federal Signal Q2B siren will only activate if the emergency master is on and parking brake is disengaged.



**** PUMP AND PLUMBING ****

PUMP

- HALE QMAX-150
- 1500 G.P.M.
- Single Stage

The pump must deliver the percentage of rated capacity at the pressure listed below:

- 100% of rated capacity at 150 P.S.I. net pump pressure
- 100% of rated capacity at 165 P.S.I. net pump pressure
- 70% of rated capacity at 200 P.S.I. net pump pressure
- 50% of rated capacity at 250 P.S.I. net pump pressure.

PUMP ASSEMBLY

The pump will be of a size and design to mount on the chassis rails of commercial and custom truck chassis and have the capacity of 1500 gallons per minute (U.S. GPM), NFPA-1901 rated performance.

PUMP CONSTRUCTION

The entire pump will be manufactured and tested at the pump manufacturer's factory.

The pump will be driven by a drive line from the truck transmission. The engine will provide sufficient horsepower and RPM to enable the pump to meet and exceed its rated performance.

The entire pump, both suction and discharge passages, will be hydrostatically tested to a pressure of 600 PSI. The pump will be fully tested at the pump manufacturer's factory to performance specs as outlined by the latest NFPA-1901. Pump will be free from objectionable pulsation and vibration.

The pump body and related parts will be of fine grain alloy cast iron with a minimum tensile strength of 30,000 PSI. All moving parts in contact with water will be of high quality bronze or stainless steel. Pumps utilizing castings made of lower tensile strength cast iron are not acceptable.

Pump body will be horizontally split, on a single plane in two sections for easy removal of entire impeller assembly including wear rings and bearings from beneath the pump without disturbing piping or the mounting of the pump in chassis.

PUMP SHAFT

Pump shaft to be rigidly supported by three bearings for minimum deflection. One high lead bronze sleeve bearing will be located immediately adjacent to the impeller (on side opposite the gearbox). The sleeve bearing is to be lubricated by a force fed, automatic oil lubricated design, pressure balanced to exclude foreign material.

The pump shaft will be heat-treated, electric furnace, corrosion resistant stainless steel to be super-finished under packing with galvanic corrosion (zinc foil separators in packing) protection for longer shaft life. Pump shaft must be sealed with double-lip oil seal to keep road dirt and water out of gearbox.



PUMP IMPELLER

The pump will have one double suction impeller. The pump body will have two opposed discharge volute cut waters to eliminate radial unbalance. (No exceptions)

Pump impeller will be hard, fine grain bronze of the mixed flow design; accurately machined and individually balanced. The vanes of the impeller intake eyes will be of sufficient size and design to provide ample reserve capacity utilizing minimum horsepower.

Impeller clearance rings will be bronze, easily renewable without replacing impeller or pump volute body, and of wrap-around double labyrinth design for maximum efficiency.

MECHANICAL SHAFT SEAL

The mid ship pump will be equipped with a high quality, spring loaded, self-adjusting mechanical seal capable of providing a positive seal to atmosphere under all pumping conditions. This positive seal to atmosphere must be achievable under vacuum conditions up to 26 Hg (draft) or positive suction pressures up to 250 PSI.

The mechanical seal assembly will be 2 inches in diameter and consists of a carbon sealing ring, stainless steel coil spring, Viton rubber boot, and a tungsten carbide seat with a Teflon backup seal provided.

Only one (1) mechanical seal will be required, located on the first stage suction (inboard) side of the pump and be designed to be compatible with a one piece pump shaft. A continuous cooling flow of water from the pump will be directed through the seal chamber when the pump is in operation.

PUMP DRIVE UNIT

The drive unit will be completely assembled and tested at the pump manufacturer's factory.

Pump drive unit will be of sufficient size to withstand up to 16,000 lbs. ft. of torque of the engine in both road and pump operating conditions. The drive unit will be designed of ample capacity for lubrication reserve and to maintain the proper operating temperature.

The gearbox drive shafts will be of heat treated chrome nickel steel and at least 2-3/4 inches in diameter on both the input and output drive shafts. They will withstand the full torque of the engine in both road and pump operating conditions.

All gears, both drive and pump, will be of the highest quality electric furnace chrome nickel steel. Bores will be ground to size and teeth integrated, chrome-shaven and hardened, to give an extremely accurate gear for long life, smooth, quiet running and higher load carrying capability. An accurately cut spur design will be provided to eliminate all possible end thrust.

PUMP RATIO

The pump ratio will be selected by the apparatus manufacturer to give maximum performance with the engine and transmission selected.

The manufacturer will supply at time of delivery copies of the pump manufacturer's certification of hydrostatic testing, the engine manufacturer's current certified brake horsepower curve.

PUMP SHIFT CONTROL

The drive unit will be equipped with a power shift. The shifting mechanism will be a heat treated, hard anodized aluminum power cylinder with stainless steel shaft. An in-cab control for rapid shift will be provided that locks in road or pump, with a manual override is required.



EMERGENCY PUMP SHIFT

An emergency manual pump shift control will be furnished on the left side pump panel which may be utilized if the air shift control does not operate.

A transmission, manual lock-up switch will be furnished in the cab to ensure positive lock-up of the transmission.

MAIN PUMP - PUMP SHIFT INDICATOR LIGHTS

For automatic transmissions, three (3) green warning lights will be provided to indicate to the operator(s) when the pump has completed the shift for Road to Pump position. Two (2) green lights to be located in the truck driving compartment and one (1) green light on pump operator's panel adjacent to the throttle control. For manual transmissions, one (1) green warning light will be provided for the driving compartment. All lights to have appropriate identification/instruction plates.

MAIN PUMP MOUNTS

Extra heavy duty pump mounting brackets will be furnished. These will be bolted to the frame rails in such a position to perfectly align the pump so that the angular velocity of the drive line joints will be the same on each end of the drive shaft. This will assure full capacity performance with a minimum of vibration. Mounting hardware will utilize Grade 8 bolts.



FIRE RESEARCH "IN-CONTROL" PRESSURE GOVERNOR

The apparatus will be equipped with a Fire Research InControl series TGA300 pressure governor and monitoring display kit will be installed. The kit will include a control module, intake pressure sensor, discharge pressure sensor, and cables. The control module case will be waterproof and have dimensions not to exceed 5 1/2" high by 10 1/2" wide by 2" deep. Inputs for monitored information will be from a J1939 databus or independent sensors. Outputs for engine control will be on the J1939 databus or engine specific wiring.

The following continuous displays will be provided:

- Pump discharge; shown with four daylight bright LED digits more than 1/2" high
- Pump Intake; shown with four daylight bright LED digits more than 1/2" high
- Pressure / RPM setting; shown on a dot matrix message display
- Pressure and RPM operating mode LEDs
- Throttle ready LED
- Engine RPM; shown with four daylight bright LED digits more than 1/2" high
- Check engine and stop engine warning LEDs
- Oil pressure; shown on a dual color (green/red) LED bar graph display
- Engine coolant temperature; shown on a dual color (green/red) LED bar graph display
- Transmission Temperature: shown on a dual color (green/red) LED bar graph display
- Battery voltage; shown on a dual color (green/red) LED bar graph display.
- The dot-matrix message display will show diagnostic and warning messages as they occur. It will show monitored apparatus information, stored data, and program options when selected by the operator. All LED intensity will be automatically adjusted for day and night time operation.

The program will store the accumulated operating hours for the pump and engine to be displayed with the push of a button. It will monitor inputs and support audible and visual warning alarms for the following conditions:

- High Battery Voltage
- Low Battery Voltage (Engine Off)
- Low Battery Voltage (Engine Running)
- High Transmission Temperature
- Low Engine Oil Pressure
- High Engine Coolant Temperature
- Out of Water (visual alarm only)
- No Engine Response. (visual alarm only)

The program features will be accessed via push buttons located on the front of the control panel. There will be an USB port located at the rear of the control module to upload future firmware enhancements.

Inputs to the control panel from the pump discharge and intake pressure sensors will be electrical. The discharge pressure display will show pressures from 0 to 600 psi. The intake pressure display will show pressures from -30 in. Hg to 600 psi.

The governor will operate in two control modes, pressure and RPM. No discharge pressure or engine RPM variation will occur when switching between modes. A throttle ready LED will light when the interlock signal is recognized. The governor will start in pressure mode and set the engine RPM to idle. In pressure mode the governor will automatically regulate the discharge pressure at the level set by the operator. In RPM mode the governor will maintain the engine RPM at the level set by the operator except in the event of a discharge pressure increase. The governor will limit a discharge pressure increase in RPM mode to a maximum of 30 psi. Other safety features will include recognition of no water conditions with an automatic programmed response and a push button to return the engine to idle.

The pressure governor, monitoring and master pressure display will be programmed to interface with a specific engine.



AKRON INTAKE RELIEF VALVE

A 300 psi adjustable Akron Model 53 - 1103 intake relief valve system will be plumbed on the suction side of the pump to comply fully with NFPA-1901 requirements. Excess pressures will be plumbed to discharge water under the pump enclosure away from the pump operator.

PUMP CERTIFICATION

The pump will be third party performance tested to meet the requirements of NFPA-1901. To ensure top quality and integrity, the test company will be Underwriters Laboratories (UL).

TRIDENT MANUAL PUMP PRIMER

The priming pump will be a Trident Manual 3 Barrel push button air primer system, #31.001.2. A push in primer handle will open the priming valve and prime the pump.

MASTER DRAIN VALVE

A Class One, rotary type, 12 port multiple master drain valve will be provided and controlled at the lower portion of the side pump panel. The valve will be located in pump compartment lower than the main body and connected in such a manner as to allow complete water drainage of the pump body and all required accessories. Water will be drained below the apparatus body and away from the pump operator.

INDIVIDUAL BLEEDERS AND DRAINS

All lines will drain through the master drain valve or will be equipped with individual drain valves, easily accessible and labeled.

One (1) individual "Innovative Control" lift up drain valve, IC# 3003084-1-02-0, will be furnished for each 1-1/2" or larger discharge port and each 2-1/2" gated auxiliary suction.

Drain/bleeder valves will be located at the bottom of the side pump module panels.

All drains and bleeders will discharge below the running boards.

SYNFLEX SUCTION, DISCHARGE, PRESSURE AND CONTROL LINES

Small lines within the pump enclosure will be constructed from Synflex hose. Uses include but are not limited to such lines as priming control, gauge lines, drain lines, air control valves, pump shift, supplemental cooling, foam flush and air bleeder valves.

THREE (3) HALE ALLOY ANODES

Three (3) Hale Alloy Anodes will be provided and located two (2) on the suction side and one (1) on the discharge side of the pump to protect the pump and other critical pump components from corrosion.

THERMAL RELIEF VALVE

A Hale Model TRV120 Thermal Relief Valve will be provided on the pump. If water temperature in the pump exceeds 120 degrees Fahrenheit, the thermal relief valve will automatically open and discharge pump water to the ground, through a 3/8" discharge line, routed below the pump module. The thermal relief valve will automatically close when the water temperature is lowered.

An audible alarm and indicator light will be provided on the operator's panel to illuminate when the thermal relief valve is activated.



PUMP MODULE

The pump module will be a self-supported structure mounted independently from the body and chassis cab. The design must allow normal frame deflection without imposing stress on the pump module structure or side running boards. The pump module will be securely mounted to the chassis frame rails.

The pump module will be a welded frame work utilizing structural aluminum components properly braced to withstand the rigors of chassis frame flex.

DUNNAGE AREA

A dunnage area will be provided above the pump enclosure for equipment mounting and storage. This area will be furnished with a removable 3/16" aluminum tread plate floor and will be enclosed on the sides.

NOTE: The size of this storage area may vary when top mounted crosslays, booster reel(s), etc., are specified and located in this area.



****** PUMP SUCTIONS & AUXILIARY INLETS ******

SUCTION INLETS

Two (2) 6" N.S.T. suction inlets will be provided, one on the driver side and one on the officer side pump panel. A removable strainer will be installed on each inlet.

PUMP SUCTION ENDS

The main pump suction inlets will be furnished with a short suction end, terminating with only the suction threads protruding through the side panel to minimize the distance an exterior appliance protrudes beyond the pump panel.

MAIN SUCTION INLET - 6" NST LONG HANDLE PRESSURE VENTED CAPS

Two (2) 6" NST aluminum plated long handle pressure vented caps will be installed on each main inlet of the pump.

AUXILIARY SIDE SUCTION(S)

DRIVER SIDE AUXILIARY SUCTION

One (1) 2-1/2" auxiliary suction will be provided at the driver side pump panel, to the rear of the main inlet. The 2-1/2" auxiliary suction will terminate with a removable strainer, chrome plated 2-1/2" NST female swivel with a chrome plated plug and retaining chain.

DRIVER'S SIDE REAR AUXILIARY SUCTION - 2 1/2" AKRON BRASS SWING OUT VALVE

An Akron Brass 2 1/2" Generation II Swing-Out™ Valve will be provided for the driver's side rear auxiliary suction. The valve will have an all brass body with flow optimizing stainless steel ball and dual polymer seats.

DRIVER'S SIDE REAR AUXILIARY SUCTION - 1/4 TURN SWING CONTROL HANDLE

The driver side rear auxiliary suction valve actuation will be equipped with Innovative Controls Swing Handle Control on the pump panel.

The ergonomically designed swing handle will be chrome-plated zinc with an etched garnish plate.

All side gated inlet valves will be recess mounted behind the side pump panels or body panels.



TANK TO PUMP

One (1) 3" tank to pump line will be piped through the front bulkhead of the tank with a 90 degree elbow down into the tank sump. This line will be plumbed directly into the rear of the pump suction manifold for maximum efficiency.

A check valve will be provided to prevent accidental pressurization of the water tank through the pump connection. Connection from the valve to the tank will be made by using a non-collapsible flexible rubber hose.

TANK TO PUMP - 3" AKRON BRASS SWING OUT VALVE

An Akron Brass 3" Generation II Swing-Out™ Valve will be provided between the pump suction manifold and the water tank. The valve will have an all brass body with flow optimizing stainless steel ball and dual polymer seats.

TANK TO PUMP - INNOVATIVE CONTROLS 1/4 TURN PUSH PULL T-HANDLE VALVE CONTROL

The tank to pump valve will be actuated with an Innovative Controls Side Mount Valve Control on the operator's panel.

The ergonomically designed ¼ turn push-pull T-handle will be chrome-plated zinc with recessed labels for color-coding and verbiage. The patented geared control rod, double-laminated locking clips, and rod housing will be stainless steel and provide a true positive lock that will eliminate valve drift. Bronze and Teflon impregnated stainless steel bushings in both ends of rod housing will minimize rod deflection, never need lubrication, and ensure consistent long-term operation.

TANK FILL

One (1) 2" gated full flow pump to tank refill line controlled at the pump panel will be provided. A deflector shield inside the tank will be furnished. Tank fill plumbing will utilize 2" high pressure hose for tank connection to accommodate flexing between components.

TANK FILL - 2" AKRON BRASS SWING OUT VALVE

An Akron Brass 2" Generation II Swing-Out™ Valve will be provided between the pump discharge manifold and the water tank. The valve will have an all brass body with flow optimizing stainless steel ball and dual polymer seats.

TANK FILL - INNOVATIVE CONTROLS 1/4 TURN PUSH PULL T- HANDLE

The tank fill valve will be actuated with an Innovative Controls Side Mount Valve Control on the operator's panel.

The ergonomically designed ¼ turn push-pull T-handle will be chrome-plated zinc with recessed labels for color-coding and verbiage. The patented geared control rod, double-laminated locking clips, and rod housing will be stainless steel and provide a true positive lock that will eliminate valve drift. Bronze and Teflon impregnated stainless steel bushings in both ends of rod housing will minimize rod deflection, never need lubrication, and ensure consistent long-term operation.



**** DISCHARGES & ACCESSORIES -SIDE MOUNT ****

DRIVER'S SIDE MAIN DISCHARGE #1

A discharge will be provided and located at the driver's side pump panel. The driver's side discharges # 1 will terminate with NST threads, through the left panel above the main pump intake.

The main pump discharge will be plumbed directly from the pump discharge manifold utilizing direct connect discharge valve flanges.

DRIVER'S SIDE DISCHARGE #1 - 2 1/2" AKRON BRASS SWING OUT VALVE

An Akron Brass 2 1/2" Generation II Swing-Out™ Valve will be provided for the driver's side #1 discharge. The valve will have an all brass body with stainless steel ball valve utilizing HydroMax Technology.

The discharge valve will be equipped with a straight 2 1/2" NST adapter that will be equipped with a 2 1/2" NST, 30-degree, chrome plated elbow.

DRIVER'S SIDE DISCHARGE #1 - 2 1/2" NST PRESSURE VENTED CAP

A 2 1/2 " NST chrome plated pressure vented cap will be installed on driver's side #1 discharge.

DRIVER SIDE DISCHARGE #1 - INNOVATIVE CONTROLS 1/4 TURN PUSH PULL T- HANDLE

The driver's side #1 discharge valve will be equipped with an Innovative Controls Side Mount Valve Control on the operator's panel.

The ergonomically designed ¼ turn push-pull T-handle will be chrome-plated zinc with recessed labels for color-coding and verbiage. The patented geared control rod, double-laminated locking clips, and rod housing will be stainless steel and provide a true positive lock that will eliminate valve drift. Bronze and Teflon impregnated stainless steel bushings in both ends of rod housing will minimize rod deflection, never need lubrication, and ensure consistent long-term operation.

INNOVATIVE CONTROLS PRESSURE GAUGE DRIVER SIDE DISCHARGE #1

The driver's side # will be equipped with a 2 ½" diameter Innovative Controls pressure gauge. The gauge will have a rugged corrosion free stainless steel case and clear scratch resistant molded crystals with captive O-ring seals to ensure distortion free viewing and seal the gauge. The gauge will be filled with glycerin to dampen shock and vibration, lubricate the internal mechanisms, prevent lens condensation and ensure proper operation from -40°F to +160°F.

The gauge will exceed ANSI B40.1 Grade A requirements with an accuracy of +/- 1.5% full scale and include a size appropriate phosphorous bronze bourdon tube with a reinforced lap joint and large tube base to increase the tube life and gauge accuracy.

A polished chrome-plated stainless steel bezel will be provided to prevent corrosion and protect the lens and gauge case. The gauge will have black graphics on a white background.



DRIVER'S SIDE MAIN DISCHARGE #2

A discharge will be provided and located at the driver's side pump panel. The driver's side discharges # 2 will terminate with NST threads, through the left panel above the main pump intake.

The main pump discharge will be plumbed directly from the pump discharge manifold utilizing direct connect discharge valve flanges.

DRIVER'S SIDE DISCHARGE #2 - 2 1/2" AKRON BRASS SWING OUT VALVE

An Akron Brass 2 1/2" Generation II Swing-Out™ Valve will be provided for the driver's side #2 discharge. The valve will have an all brass body with flow optimizing stainless steel ball and dual polymer seats.

The discharge valve will be equipped with a straight 2 1/2" NST adapter that will be equipped with a 2 1/2" NST, 30-degree, chrome plated elbow.

DRIVER'S SIDE DISCHARGE #2 - 2 1/2" NST PRESSURE VENTED CAP

A 2 1/2 " NST chrome plated pressure vented cap will be installed on driver's side #2 discharge.

DRIVER SIDE DISCHARGE #2 - INNOVATIVE CONTROLS 1/4 TURN PUSH PULL T- HANDLE

The driver's side #2 discharge valve will be equipped with an Innovative Controls Side Mount Valve Control on the operator's panel.

The ergonomically designed ¼ turn push-pull T-handle will be chrome-plated zinc with recessed labels for color-coding and verbiage. The patented geared control rod, double-laminated locking clips, and rod housing will be stainless steel and provide a true positive lock that will eliminate valve drift. Bronze and Teflon impregnated stainless steel bushings in both ends of rod housing will minimize rod deflection, never need lubrication, and ensure consistent long-term operation.

INNOVATIVE CONTROLS PRESSURE GAUGE DRIVER SIDE DISCHARGE #2

The driver's side discharge #2 will be equipped with a 2 ½" diameter Innovative Controls pressure gauge. The gauge will have a rugged corrosion free stainless steel case and clear scratch resistant molded crystals with captive O-ring seals to ensure distortion free viewing and seal the gauge. The gauge will be filled with glycerin to dampen shock and vibration, lubricate the internal mechanisms, prevent lens condensation and ensure proper operation from -40°F to +160°F.

The gauge will exceed ANSI B40.1 Grade A requirements with an accuracy of +/- 1.5% full scale and include a size appropriate phosphorous bronze bourdon tube with a reinforced lap joint and large tube base to increase the tube life and gauge accuracy.

A polished chrome-plated stainless steel bezel will be provided to prevent corrosion and protect the lens and gauge case. The gauge will have black graphics on a white background.



OFFICER'S SIDE MAIN DISCHARGE #1

A discharge will be provided and located at the officer's side pump panel. The officer's side discharges #1 will terminate with NST threads, through the officer's side panel above the main pump intake.

The main pump discharge will be plumbed directly from the pump discharge manifold utilizing direct connect discharge valve flanges.

OFFICER'S SIDE DISCHARGE #1 - 3" AKRON BRASS SWING OUT VALVE

An Akron Brass 3" Generation II Swing-Out™ Valve will be provided for the officer's side #1 discharge. The valve will have an all brass body with flow optimizing stainless steel ball and dual polymer seats.

The discharge valve will be equipped with a straight 3" NST adapter that will be equipped with a 3" NST, 30-degree, chrome plated elbow.

OFFICER'S SIDE DISCHARGE #1 - 3" NSTF X 5" STORZ STRAIGHT ADAPTER WITH CAP

One (1) 3" NSTF X 5" Storz Kocheck S37S straight adapter with cap will be provided on the officer's side #1 discharge.

OFFICER SIDE DISCHARGE #1 - INNOVATIVE CONTROLS 1/4 TURN PUSH PULL T- HANDLE

The officer's side #1 discharge valve will be equipped with an Innovative Controls Side Mount Valve Control on the operator's panel.

The ergonomically designed ¼ turn push-pull T-handle will be chrome-plated zinc with recessed labels for color-coding and verbiage. The patented geared control rod, double-laminated locking clips, and rod housing will be stainless steel and provide a true positive lock that will eliminate valve drift. Bronze and Teflon impregnated stainless steel bushings in both ends of rod housing will minimize rod deflection, never need lubrication, and ensure consistent long-term operation.

INNOVATIVE CONTROLS PRESSURE GAUGE OFFICER SIDE DISCHARGE #1

The officer's side discharge #1 will be equipped with a 2 ½" diameter Innovative Controls pressure gauge. The gauge will have a rugged corrosion free stainless steel case and clear scratch resistant molded crystals with captive O-ring seals to ensure distortion free viewing and seal the gauge. The gauge will be filled with glycerin to dampen shock and vibration, lubricate the internal mechanisms, prevent lens condensation and ensure proper operation from -40°F to +160°F.

The gauge will exceed ANSI B40.1 Grade A requirements with an accuracy of +/- 1.5% full scale and include a size appropriate phosphorous bronze bourdon tube with a reinforced lap joint and large tube base to increase the tube life and gauge accuracy.

A polished chrome-plated stainless steel bezel will be provided to prevent corrosion and protect the lens and gauge case. The gauge will have black graphics on a white background.



OFFICER'S SIDE MAIN DISCHARGE #2

A discharge will be provided and located at the officer's side pump panel. The officer's side discharges #2 will terminate with NST threads, through the officer's side panel above the main pump intake.

The main pump discharge will be plumbed directly from the pump discharge manifold utilizing direct connect discharge valve flanges.

OFFICER'S SIDE DISCHARGE #2 - 2 1/2" AKRON BRASS SWING OUT VALVE

An Akron Brass 2 1/2" Generation II Swing-Out™ Valve will be provided for the officer's side #2 discharge. The valve will have an all brass body with flow optimizing stainless steel ball and dual polymer seats.

The discharge valve will be equipped with a straight 2 1/2" NST adapter that will be equipped with a 2 1/2" NST, 30-degree, chrome plated elbow.

OFFICER'S SIDE DISCHARGE #2 - 2 1/2" NST PRESSURE VENTED CAP

A 2 1/2 " NST chrome plated pressure vented cap will be installed on officer's side #2 discharge.

OFFICER SIDE DISCHARGE #2 - INNOVATIVE CONTROLS 1/4 TURN PUSH PULL T- HANDLE

The officer's side #2 discharge valve will be equipped with an Innovative Controls Side Mount Valve Control on the operator's panel.

The ergonomically designed ¼ turn push-pull T-handle will be chrome-plated zinc with recessed labels for color-coding and verbiage. The patented geared control rod, double-laminated locking clips, and rod housing will be stainless steel and provide a true positive lock that will eliminate valve drift. Bronze and Teflon impregnated stainless steel bushings in both ends of rod housing will minimize rod deflection, never need lubrication, and ensure consistent long-term operation.

INNOVATIVE CONTROLS PRESSURE GAUGE OFFICER SIDE DISCHARGE #2

The officer's side discharge #2 will be equipped with a 2 ½" diameter Innovative Controls pressure gauge. The gauge will have a rugged corrosion free stainless steel case and clear scratch resistant molded crystals with captive O-ring seals to ensure distortion free viewing and seal the gauge. The gauge will be filled with glycerin to dampen shock and vibration, lubricate the internal mechanisms, prevent lens condensation and ensure proper operation from -40°F to +160°F.

The gauge will exceed ANSI B40.1 Grade A requirements with an accuracy of +/- 1.5% full scale and include a size appropriate phosphorous bronze bourdon tube with a reinforced lap joint and large tube base to increase the tube life and gauge accuracy.

A polished chrome-plated stainless steel bezel will be provided to prevent corrosion and protect the lens and gauge case. The gauge will have black graphics on a white background.



DRIVER SIDE HOSE BED DISCHARGE

A 2 1/2" NST rear hose bed discharge will be plumbed to the upper front body panel, extending into the front of the hose bed.

The rear hose bed discharge will terminate just above the hose bed floor, in the driver side front of the hose bed.

The driver side hose bed discharge pipe will be equipped with a chrome 2 1/2" NSTM thread adapter.

The driver side hose bed discharge will be plumbed utilizing 2 1/2" schedule 10 stainless steel piping, 45 degree elbows and a limited number of 90 degree sweep elbows in an assembly from the pump to the rear of the vehicle.

A minimum of one (1) grooved pipe coupling will be furnished in this assembly to allow for flex and serviceability.

DRIVER'S SIDE HOSE BED DISCHARGE - 2 1/2" AKRON BRASS SWING OUT VALVE

An Akron Brass 2 1/2" Generation II Swing-Out™ Valve will be provided for the driver's side hose bed discharge. The valve will have an all brass body with flow optimizing stainless steel ball and dual polymer seats.

DRIVER'S SIDE HOSE BED DISCHARGE #1 - INNOVATIVE CONTROLS 1/4 TURN PUSH PULL T-HANDLE

The driver's side hose bed discharge valve will be equipped with an Innovative Controls Side Mount Valve Control on the operator's panel.

The ergonomically designed ¼ turn push-pull T-handle will be chrome-plated zinc with recessed labels for color-coding and verbiage. The patented geared control rod, double-laminated locking clips, and rod housing will be stainless steel and provide a true positive lock that will eliminate valve drift. Bronze and Teflon impregnated stainless steel bushings in both ends of rod housing will minimize rod deflection, never need lubrication, and ensure consistent long-term operation.

INNOVATIVE CONTROLS PRESSURE GAUGE DRIVER SIDE HOSE BED DISCHARGE

The driver's side hose bed discharge will be equipped with a 2 ½" diameter Innovative Controls pressure gauge. The gauge will have a rugged corrosion free stainless steel case and clear scratch resistant molded crystals with captive O-ring seals to ensure distortion free viewing and seal the gauge. The gauge will be filled with glycerin to dampen shock and vibration, lubricate the internal mechanisms, prevent lens condensation and ensure proper operation from -40°F to +160°F.

The gauge will exceed ANSI B40.1 Grade A requirements with an accuracy of +/- 1.5% full scale and include a size appropriate phosphorous bronze bourdon tube with a reinforced lap joint and large tube base to increase the tube life and gauge accuracy.

A polished chrome-plated stainless steel bezel will be provided to prevent corrosion and protect the lens and gauge case. The gauge will have black graphics on a white background.



DECK GUN DISCHARGE

A deck gun discharge will be plumbed from the pump to an area on top of the vehicle. The deck gun piping will be firmly supported and braced.

The deck gun discharge will be located in the dunnage area above the pump module on the officer's side of the vehicle. A pedestal type, 1/4" steel plate support assembly will be provided to stabilize deck gun plumbing below deck gun mount flange.

The deck gun discharge pipe will terminate with a 4-bolt flange.

DECK GUN DISCHARGE NOT TO EXCEED TALLEST POINT

The deck gun piping will be designed so the overall height of the deck gun in the mounted/stowed position does not exceed the tallest point on the cab/body.

DECK GUN DISCHARGE PLUMBING

The deck gun discharge will be plumbed utilizing 3" schedule 10 stainless steel piping, 45 degree elbows and a limited number of 90 degree sweep elbows in an assembly from the pump to the deck gun location.

A minimum of one (1) grooved pipe coupling will be furnished in this assembly to allow for flex and serviceability.

DECK GUN DISCHARGE - 3" AKRON BRASS SWING OUT VALVE

An Akron Brass 3" Generation II Swing-Out™ Valve will be provided for the deck gun discharge. The valve will have an all brass body with flow optimizing stainless steel ball and dual polymer seats.

DECK GUN DISCHARGE #1 - INNOVATIVE CONTROLS 1/4 TURN PUSH PULL T- HANDLE

The deck gun discharge valve will be equipped with an Innovative Controls Side Mount Valve Control on the operator's panel.

The ergonomically designed ¼ turn push-pull T-handle will be chrome-plated zinc with recessed labels for color-coding and verbiage. The patented geared control rod, double-laminated locking clips, and rod housing will be stainless steel and provide a true positive lock that will eliminate valve drift. Bronze and Teflon impregnated stainless steel bushings in both ends of rod housing will minimize rod deflection, never need lubrication, and ensure consistent long-term operation.

INNOVATIVE CONTROLS PRESSURE GAUGE DECK GUN DISCHARGE

The deck gun discharge will be equipped with a 2 ½" diameter Innovative Controls pressure gauge. The gauge will have a rugged corrosion free stainless steel case and clear scratch resistant molded crystals with captive O-ring seals to ensure distortion free viewing and seal the gauge. The gauge will be filled with glycerin to dampen shock and vibration, lubricate the internal mechanisms, prevent lens condensation and ensure proper operation from -40°F to +160°F.

The gauge will exceed ANSI B40.1 Grade A requirements with an accuracy of +/- 1.5% full scale and include a size appropriate phosphorous bronze bourdon tube with a reinforced lap joint and large tube base to increase the tube life and gauge accuracy.

A polished chrome-plated stainless steel bezel will be provided to prevent corrosion and protect the lens and gauge case. The gauge will have black graphics on a white background.



1-1/2" FRONT DISCHARGE #1

A 1 1/2" front #1 discharge will be plumbed to the front bumper of the vehicle.

The front #1 discharge will terminate on the top center of the front bumper extension gravel shield with a chrome 1 1/2" NSTM chicksan swivel adapter.

The front #1 discharge will be plumbed utilizing 2" schedule 10 stainless steel piping and/or flexible hose, 45 degree elbows and a limited number of 90 degree sweep elbows in an assembly from the pump to the front of the vehicle.

A minimum of one (1) grooved pipe coupling will be furnished in this assembly to allow for flex and serviceability. Automatic discharge drains will be provided at all low points in the plumbing.

FRONT DISCHARGE #1 - 2" AKRON BRASS SWING OUT VALVE

An Akron Brass 2" Generation II Swing-Out™ Valve will be provided for the front #1 discharge. The valve will have an all brass body with flow optimizing stainless steel ball and dual polymer seats.

FRONT DISCHARGE #1 - INNOVATIVE CONTROLS 1/4 TURN PUSH PULL T- HANDLE

The front discharge #1 valve will be equipped with an Innovative Controls Side Mount Valve Control on the operator's panel.

The ergonomically designed ¼ turn push-pull T-handle will be chrome-plated zinc with recessed labels for color-coding and verbiage. The patented geared control rod, double-laminated locking clips, and rod housing will be stainless steel and provide a true positive lock that will eliminate valve drift. Bronze and Teflon impregnated stainless steel bushings in both ends of rod housing will minimize rod deflection, never need lubrication, and ensure consistent long-term operation.

INNOVATIVE CONTROLS PRESSURE GAUGE FRONT DISCHARGE #1

The front discharge #1 will be equipped with a 2 ½" diameter Innovative Controls pressure gauge. The gauge will have a rugged corrosion free stainless steel case and clear scratch resistant molded crystals with captive O-ring seals to ensure distortion free viewing and seal the gauge. The gauge will be filled with glycerin to dampen shock and vibration, lubricate the internal mechanisms, prevent lens condensation and ensure proper operation from -40°F to +160°F.

The gauge will exceed ANSI B40.1 Grade A requirements with an accuracy of +/- 1.5% full scale and include a size appropriate phosphorous bronze bourdon tube with a reinforced lap joint and large tube base to increase the tube life and gauge accuracy.

A polished chrome-plated stainless steel bezel will be provided to prevent corrosion and protect the lens and gauge case. The gauge will have black graphics on a white background.



CROSSLAY #1

A crosslay hose bed will be provided and plumbed from the pump in a transverse design, located above the body for quick attack deployment. The crosslay hose bed flooring will be designed to be removable, constructed from brushed finish, perforated aluminum material.

Crosslay #1 will be designed to have a minimum total capacity of 3.5 cubic feet as required by NFPA - 1901 to accommodate a minimum of 200 feet of 1-3/4" fire hose.

Crosslay #1 hose bed will be designed to accommodate the fire hose in a double stack configuration.

The crosslay discharge will terminate below the hose bed floor with a 1 1/2" NSTM chicksan swivel adapter. The crosslay hose bed floor will be slotted to allow the swivel to extend up through the floor, allowing the pre-connected hose to be pulled off either side of the apparatus without kinking the hose at the coupling connection.

The crosslay #1 discharge will be plumbed utilizing 2" schedule 10 stainless steel piping and/or flexible hose, 45 degree elbows and a limited number of 90 degree sweep elbows in an assembly from the pump to crosslay hose bed.

A minimum of one (1) grooved pipe coupling will be furnished in this assembly, if necessary, to allow for flex and serviceability.

CROSSLAY DISCHARGE #1 - 2" AKRON BRASS SWING OUT VALVE

An Akron Brass 2" Generation II Swing-Out™ Valve #8820 will be provided for the crosslay #1 discharge. The valve will have an all brass body with flow optimizing stainless steel ball and dual polymer seats.

CROSSLAY DISCHARGE #1 - INNOVATIVE CONTROLS 1/4 TURN PUSH PULL T- HANDLE

The crosslay discharge #1 valve will be equipped with an Innovative Controls Side Mount Valve Control on the operator's panel.

The ergonomically designed ¼ turn push-pull T-handle will be chrome-plated zinc with recessed labels for color-coding and verbiage. The patented geared control rod, double-laminated locking clips, and rod housing will be stainless steel and provide a true positive lock that will eliminate valve drift. Bronze and Teflon impregnated stainless steel bushings in both ends of rod housing will minimize rod deflection, never need lubrication, and ensure consistent long-term operation.

INNOVATIVE CONTROLS PRESSURE GAUGE CROSSLAY #1

The crosslay discharge #1 will be equipped with a 2 ½" diameter Innovative Controls pressure gauge. The gauge will have a rugged corrosion free stainless steel case and clear scratch resistant molded crystals with captive O-ring seals to ensure distortion free viewing and seal the gauge. The gauge will be filled with glycerin to dampen shock and vibration, lubricate the internal mechanisms, prevent lens condensation and ensure proper operation from -40°F to +160°F.

The gauge will exceed ANSI B40.1 Grade A requirements with an accuracy of +/- 1.5% full scale and include a size appropriate phosphorous bronze bourdon tube with a reinforced lap joint and large tube base to increase the tube life and gauge accuracy.

A polished chrome-plated stainless steel bezel will be provided to prevent corrosion and protect the lens and gauge case. The gauge will have black graphics on a white background.



CROSSLAY #2

A crosslay hose bed will be provided and plumbed from the pump in a transverse design, located above the body for quick attack deployment. The crosslay hose bed flooring will be designed to be removable, constructed from brushed finish, perforated aluminum material.

Crosslay #2 will be designed to have a minimum total capacity of 3.5 cubic feet as required by NFPA - 1901 to accommodate a minimum of 200 feet of 1-3/4" fire hose.

Crosslay #2 hose bed will be designed to accommodate the fire hose in a double stack configuration.

The crosslay discharge will terminate below the hose bed floor with a 1 1/2" NSTM chicksan swivel adapter. The crosslay hose bed floor will be slotted to allow the swivel to extend up through the floor, allowing the pre-connected hose to be pulled off either side of the apparatus without kinking the hose at the coupling connection.

The crosslay #2 discharge will be plumbed utilizing 2" schedule 10 stainless steel piping and/or flexible hose, 45 degree elbows and a limited number of 90 degree sweep elbows in an assembly from the pump to crosslay hose bed.

A minimum of one (1) grooved pipe coupling will be furnished in this assembly, if necessary, to allow for flex and serviceability.

CROSSLAY DISCHARGE #2 - 2" AKRON BRASS SWING OUT VALVE

An Akron Brass 2" Generation II Swing-Out™ Valve will be provided for the crosslay #2 discharge. The valve will have an all brass body with flow optimizing stainless steel ball and dual polymer seats.

CROSSLAY DISCHARGE #2 - INNOVATIVE CONTROLS 1/4 TURN PUSH PULL T- HANDLE

The crosslay discharge #2 valve will be equipped with an Innovative Controls Side Mount Valve Control on the operator's panel.

The ergonomically designed ¼ turn push-pull T-handle will be chrome-plated zinc with recessed labels for color-coding and verbiage. The patented geared control rod, double-laminated locking clips, and rod housing will be stainless steel and provide a true positive lock that will eliminate valve drift. Bronze and Teflon impregnated stainless steel bushings in both ends of rod housing will minimize rod deflection, never need lubrication, and ensure consistent long-term operation.

INNOVATIVE CONTROLS PRESSURE GAUGE CROSSLAY #2

The crosslay discharge #2 will be equipped with a 2 ½" diameter Innovative Controls pressure gauge. The gauge will have a rugged corrosion free stainless steel case and clear scratch resistant molded crystals with captive O-ring seals to ensure distortion free viewing and seal the gauge. The gauge will be filled with glycerin to dampen shock and vibration, lubricate the internal mechanisms, prevent lens condensation and ensure proper operation from -40°F to +160°F.

The gauge will exceed ANSI B40.1 Grade A requirements with an accuracy of +/- 1.5% full scale and include a size appropriate phosphorous bronze bourdon tube with a reinforced lap joint and large tube base to increase the tube life and gauge accuracy.

A polished chrome-plated stainless steel bezel will be provided to prevent corrosion and protect the lens and gauge case. The gauge will have black graphics on a white background.



CROSSLAY COVER

A vinyl cross lay cover will be provided. It will be securely fastened at the front with snaps and Velcro at the rear, with straps to secure each end flap.

The crosslay cover will be red in color.



PUMP PANEL - SIDE MOUNT

The pump operator's control panel will be located on the driver side of the apparatus. The pump enclosure side panels will be completely removable and designed for easy access and servicing.

PUMP PANEL MATERIAL

The left side operator's panel, gauge panel, right side pump panel and right side access door will be fabricated from 1/8" aluminum, coated with All Pro Linings material. All Pro Linings is a 100% solids, two component, spray applied, polyurea hybrid coating.

HINGED GAUGE PANEL

A full width, vertically hinged gauge access panel will be provided at the operator's position. Chrome plated positive locks will be provided along with chain holders to prevent the front of the gauge panel from coming in contact with other panels when open.

VERTICALLY HINGED, SPLIT PUMP PANEL OFFICER SIDE

The officer's side pump panel will be split, vertically hinged, to provide complete access to the pump and plumbing on the officer side of the pump enclosure. The panels will be equipped with stainless steel hinges and secured with push type locks to hold the panels closed. The drains located on the officer's side panel will be fastened to the lower panel, which will be stationary.

CAPS AND ADAPTERS SAFETY TETHER

All applicable discharge and suction caps, plugs and adapters will be equipped with chrome plated ball chain and secured to the vehicle.

DISCHARGE GAUGE TRIM BEZELS

Each individual discharge gauge will be installed into a decorative chrome-plated mounting bezel that incorporates valve-identifying verbiage and color labels.

COLOR CODED IDENTIFICATION TAGS

Color coded identification tags will be provided for all gauges, controls, connections, switches, inlets and outlets.

PUMP OPERATOR'S PANEL LIGHT SHIELD AND STEP

The pump operator's panel will be equipped with a light shield/step that will be full width of the control panel and will be positioned to cover the lights and prevent glare. The light shield will be fabricated from aluminum tread plate, which will also serve as a step. The step will be a minimum of 8" deep X the width of the pump panel. (Note: On apparatus with lowered style crosslays, the light shield will be from the back of the crosslays to the rear of the pump house).

The light shield will be equipped with the following lights:

- Four (4) TecNiq #E18 LED lights

One (1) light under the operator's panel light shield will be actuated when fire pump is engaged in addition to the pump engaged light.



OFFICER SIDE PUMP PANEL LIGHT SHIELD AND STEP

The officer side pump panel will be equipped with a light shield/step that will be full width of the panel and will be positioned to cover the lights and prevent glare. The light shield will be fabricated from aluminum tread plate, which will also serve as a step. The step will be a minimum of 8" deep X the width of the pump panel.

The light shield will be equipped with the following lights:

- Four (4) TecNiq E18 LED lights.

The lights will be switched with the operator panel lights.

PUMP OPERATOR'S PANEL

Particular attention is to be given to functional arrangement of all controls. The pump operator's panel will accommodate the following:

- Hinged gauge panel
- Water tank fill valve
- Auxiliary suction valve control
- All discharge valve controls
- Auxiliary engine cooler controls
- Water tank suction control valve
- Pump primer valve
- Engine throttle control
- Master compound vacuum gauge
- Master pressure gauge
- Individual discharge gauges
- Pump shift engaged indicator light
- Water tank water level indicator
- Engine tachometer
- Engine oil pressure gauge with audible alarm
- Engine water temperature gauge with audible alarm
- Low voltage light and audible alarm
- Pump panel light switch
- Speed counter (Underwriters)
- Pump performance plate (Underwriters)
- Pump serial No. plate
- Master pump drain valve
- Individual drains
- Voltmeter
- Air inlet/outlet at lower driver side panel
- Fire Research #TGA300 "In Control" pressure governor control

PUMP TEST PORTS

The pump panel will be equipped with Vacuum & Pressure test plugs to allow for test equipment to monitor pump pressure and vacuum levels. Chrome plugs and labels will be provided for the test ports.

ENGINE COOLER

An auxiliary cooler or heat exchanger will be installed in the engine compartment between the engine and the chassis radiator. The cooler will permit the use of water from the pump for cooling the engine. The cooling will be done without mixing engine and pump water.



MASTER GAUGES

One (1) 4" diameter pressure gauge (labeled: "PRESSURE") and one (1) 4" diameter compound vacuum gauge (labeled: "INTAKE") will be provided. The master gauges will be Innovative Controls glycerin filled. The gauge faces will be white with black numerals.

PRESSURE & COMPOUND GAUGE RANGES

All applicable pressure gauges will have a range of 0 - 400 P.S.I., and the compound gauge will have a range of -30" - 0 - 400 P.S.I.

FIRE RESEARCH TANKVISION WATER TANK VOLUME INDICATOR

A Fire Research TankVision Pro model WLA300-A00 tank indicator kit will be provided. The kit will include an electronic indicator module, a pressure sensor, and a 10' sensor cable. The indicator will show the volume of water in the tank on nine (9) easy to see super bright RGB LEDs. A wide view lens over the LEDs will provide for a viewing angle of 180 degrees. The indicator case will be waterproof, manufactured of Polycarbonate/Nylon material, and have a distinctive blue label.

The program features will be accessed from the front of the indicator module. The program will support self-diagnostics capabilities, self-calibration, six (6) programmable colored light patterns to display tank volume, adjustable brightness control levels and a datalink to connect remote indicators. Low water warnings will include flashing LEDs at 1/4 tank, down chasing LEDs when the tank is almost empty, and an output for an audio alarm.

The indicator will receive an input signal from an electronic pressure sensor. The sensor will be mounted from the outside of the water tank near the bottom. No probe will be placed on the interior of the tank. Wiring will be weather resistant and have automotive type plug-in connectors.

Location of water tank indicator shall be: TBD

The gauge will use a pressure transducer installed near the bottom of the water tank to determine the correct volume in the tank.



1000 GALLON WATER T-TANK

The water tank will have a capacity of 1000 U.S. gallons and will be constructed of PT3™ polypropylene material. This material will be a non-corrosive stress relieved thermoplastic and UV stabilized for maximum protection. Tank shell thickness may vary depending on the application and may range from ½ to 1" as required. Internal baffles are generally 3/8" in thickness.

WATER TANK ISO CERTIFICATION

The tank must be designed and fabricated by a tank manufacturer that is ISO 9001:2008 certified in each of its locations. The ISO certification must be to the current standard in effect at the time of the design and fabrication of the tank.

WATER TANK CONSTRUCTION

The tank will be of a specific configuration and is so designed to be completely independent of the body and compartments. Joints and seams will be fused using nitrogen gas as required and tested for maximum strength and integrity. The tank construction will include PolyProSeal™ technology wherein a sealant will be installed between the plastic components prior to being fusion welded. This sealing method will provide a liquid barrier offering leak protection in the event of a weld compromise. The top of the booster tank is fitted with removable lifting assembly designed to facilitate tank removal. The transverse and longitudinal swash partitions will be manufactured of a minimum of 3/8" PT3™ polypropylene. All partitions will be equipped with vent and air holes to permit movement of air and water between compartments. The partitions will be designed to provide maximum water flow. All swash partitions interlock with one another and are completely fused to each other as well as to the walls of the tank. All partitions and spacing will comply with NFPA 1901. The walls will be welded to the floor of the tank providing maximum strength as part of the tank's unique Full Floor Design™. Tolerances in design allow for a maximum variation of 1/8" on all dimensions.

WATER TANK CAPACITY CERTIFICATION

All water and foam tanks will be tested and certified as to capacity on a calibrated and certified tilting scale. Each tank will be weighed empty and full to provide precise fluid capacity. Each Poly-Tank® III is delivered with a Certificate of Capacity delineating the weight empty and full and the resultant capacity based on weight. Engineering estimates for capacity calculations will not be permitted for capacity certification.

WATER TANK CENTER OF GRAVITY

A center of gravity calculation will be determined for each tank and provided as requested in order to provide the apparatus manufacturer with the necessary data to design and certify the apparatus with respect to the NFPA requirements regarding rollover stability. This information may be used by the apparatus manufacturer to assist in the calculation of the apparatus's ability to meet the tilt table static rollover threshold or calculated Center of Gravity requirements per NFPA. A center of gravity and weight calculation for both empty and full conditions will be required with each tank.

WATER TANK TANKNOLOGY™ TAG

A tag will be installed on the apparatus in a convenient location and contain pertinent information including a QR code readable by commercially available smart phones. The information contained on the tag will include the capacity of the water and foam (s), the maximum fill and pressure rates, the serial number of the tank, the date of manufacture, the tank manufacturer, and contact information. The QR code will allow the user to connect with the tank manufacturer for additional information and assistance.



WATER TANK LID

The tank cover will be constructed of 1/2" thick PT3 polypropylene and UV stabilized, to incorporate a multi-piece locking design, which allows for individual removal and inspection if necessary. The tank cover(s) will be flush or recessed 3/8" from the top of the tank and will be fused to the tank walls and longitudinal partitions for maximum integrity. Each one of the covers will have hold downs consisting of 2" minimum polypropylene dowels spaced a maximum of 40" apart. These dowels will extend through the covers and will assist in keeping the covers rigid under fast filling conditions. A minimum of two lifting dowels will accommodate the necessary lifting hardware.

WATER FILL TOWER AND COVER

The tank will have a combination vent and manual fill tower. The fill tower will be constructed of 1/2" PT3™ polypropylene and will be a minimum dimension of 12" x 12" outer perimeter. The fill tower will be blue in color indicating that it is a water-only fill tower. The tower will be located in the left front corner of the tank unless otherwise specified by the tank manufacturer to the purchaser. The tower will have a 1/4" thick removable polypropylene screen and a PT3™ polypropylene hinged cover. The capacity of the tank will be engraved on the top of the fill tower lid. Inside the fill tower there will be a combination vent/overflow pipe. The vent overflow will be a minimum of schedule 40 polypropylene pipe with a minimum I.D. of 4" that is designed to run through the tank and will be piped to discharge water behind the rear wheels as required in NFPA 1901 so as to not interfere with rear tire traction.

The tank cover will be constructed of 1/2" thick PT3™ polypropylene and UV stabilized, to incorporate a multi-piece locking design, which allows for individual removal and inspection if necessary. The tank cover(s) will be flush or recessed 3/8" from the top of the tank and will be fused to the tank walls and longitudinal partitions for maximum integrity. Each one of the covers will have hold downs consisting of 2" minimum polypropylene dowels spaced a maximum of 40" apart. These dowels will extend through the covers and will assist in keeping the covers rigid under fast filling conditions. A minimum of two lifting dowels will accommodate the necessary lifting hardware.

OVERFLOW AND VENT PIPE

The vent overflow will be a minimum of schedule 40 polypropylene pipe with a minimum I.D. of 4" that is designed to run through the tank and will be piped to discharge water behind the rear wheels as required in NFPA 1901 so as to not interfere with rear tire traction.

WATER TANK SUMP

There will be one (1) sump standard per tank. The sump will be constructed of a minimum of 1/2" PT3™ polypropylene and will be located in the left front quarter of the tank, unless specified otherwise.

WATER TANK 3" SUMP DRAIN

On all tanks that require a front suction, a 3" schedule 40 polypropylene pipe will be installed that will incorporate a dip tube from the front of the tank to the sump location. The sump will have a minimum 3" N.P.T. threaded outlet on the bottom for a drain plug per NFPA. This will be used as a combination clean-out and drain. All tanks will have an anti-swirl plate located approximately 3" above the inside floor.



WATER TANK OUTLETS

There will be two (2) standard tank outlets; one for tank-to-pump suction line which will be a minimum of 4" coupling and one for a tank fill line which will be a minimum of a 2" NPT coupling.

All tank fill couplings will be backed with flow deflectors to break up the stream of water entering the tank, and be capable of withstanding sustained fill rates of up to 1000 G.P.M. The addition of rear suction fittings, nurse valve fittings, dump valve fittings, and through-the-tank sleeves to accommodate rear discharge piping must be specified. All auxiliary outlets and inlets must meet all NFPA guidelines in effect at the time of manufacture.

WATER TANK MOUNTING

The UPF Poly-Tank® III will rest on the body cross members in conjunction with such additional cross members, spaced at a distance that would not allow for more than 530 square inches of unsupported area under the tank floor. In cases where overall height of the tank exceeds 40 inches, cross member spacing must be decreased to allow for not more than 400 square inches of unsupported area.

The tank must be isolated from the cross members through the use of hard rubber strips with a minimum thickness and width dimension of 1/4" x 1" and a Shore A Hardness of approximately 60 durometer. The rubber must be installed so it will not become dislodged during normal operation of the vehicle. Additionally, the tank must be supported around the entire bottom outside perimeter and captured both in the front and rear as well as side to side to prevent tank from shifting during vehicle operation.

A picture frame type cradle mount with a minimum of 2" x 2" x 1/4" mild steel, stainless steel, or aluminum angle shall be provided or the use of corner angles having a minimum dimension of 4" x 4" x 1/4" by 6" high are permitted for the purpose of capturing the tank.

Although the tank is designed on a free floating suspension principle, it is required that the tank have adequate vertical hold down restraints to minimize movement during vehicle operation. If proper retention has not been incorporated into the apparatus hose floor structure, an optional mounting restraint system shall be located on top of the tank, half way between the front and the rear on each side of the tank. These stops can be constructed of steel, stainless steel or aluminum angle having minimum dimensions of 3" x 3" x 1/4" and shall be approximately 6" to 12" long. These brackets must incorporate rubber isolating pads with a minimum thickness of 1/4" inch and a hardness of 60 durometer affixed on the underside of the angle. The angle should then be bolted to the body side walls of the vehicle while extending down to rest on the top outside edge of the upper side wall of the tank. Hose beds floors must be so designed that the floor slat supports extend full width from side wall to side wall and are not permitted to drop off the edge of the tank or in any way come in contact with the individual covers where a puncture could occur. Tank top must be capable of supporting loads up to 200 lbs. per sq. foot when evenly distributed. Other equipment such as generators, portable pumps, etc. must not be mounted directly to the tank top unless provisions have been designed into the Poly-Tank® III for that purpose. The tank shall be completely removable without disturbing or dismantling the apparatus structure.



APPARATUS BODY DESIGN CONSTRUCTION

The body side and compartment assemblies will be designed and assembled to provide maximum strength and durability under all operating conditions.

Special attention will be taken to minimize corrosion on all fabricated parts and structural members of the body. All bolt-on components will be provided with a dissimilar metals isolation barrier to prevent electric corrosion.

The body assembly will be an all-welded configuration. The body will be completely isolated from the cab and pump module structure.

BODY AND COMPARTMENT FABRICATION - 3/16" ALUMINUM

All compartment floor and back wall panels will be entirely 3/16" aluminum (5052-H32). All compartment roof and side wall panels, component storage sleeves (unless specified otherwise), and body side sheets will be entirely 1/8" aluminum (5052-H32). Each compartment panel and/or body side sheet will be both plug welded and stitch welded to ensure proper weld penetration on all panels while avoiding the possible warping caused by a full seam weld. A full seam weld will not be used due to the applied heat which could distort sheet metal and remove the protective coating from the perimeter of the welded area. All seams will be caulked prior to finish paint to ensure proper compartment seal.

BODY SUBFRAME - ALUMINUM

The main body subframe will be an all-welded configuration utilizing a combination of 3" x 2" 6061-T6 aluminum 1/4" (.250") wall tubing and 2" x 2" 6061-T6 aluminum 3/16" (.1875") wall tubing.

The rest of the body subframe structure will be an all-welded configuration utilizing a combination of 4"x 2" 6061-T6 aluminum 1/4" (.250") wall tubing, 3" x 2" 6061-T6 aluminum 1/4" (.250") wall tubing, 2" x 2" 6061-T6 aluminum 3/16" (.1875") wall tubing, 2" x 1" 6061-T6 aluminum 1/8" (.125") wall tubing, 3" x 1" 6061-T6 aluminum 1/8" (.125") wall tubing, and 3" x 3/4" (.75") 6061-T6 aluminum flatbar.

The body subframe will also utilize 2" x 2" 6061-T6 aluminum 1/4" (.25") angle and 3" x 1.5" 6061-T6 aluminum 1/4" (.25") c-channel in areas that require additional support or mounting locations.

This body subframe will be designed to totally support the full length, height, and width of the body.

STEPPING, STANDING, & WALKING SURFACES

All stepping, standing, and walking surfaces on the body will meet NFPA #1901 anti-slip standards. 3/16" (.1875") 3003-H22 aluminum tread plate utilized for stepping, standing, and walking surfaces will be ALCOA no slip type. Upon request by the Purchaser, the manufacturer will supply proof of compliance with this requirement.

DRIVER'S SIDE COMPARTMENTATION

L1 - One (1) full height/split depth compartment, with a roll up door, will be provided forward of the rear wheels. Compartment dimensions 68" high x 48" wide x 26" deep in the lower 30" high area, 12" deep in the upper 38" high area.

L2 - One (1) high side compartment, with a roll up door, will be provided above the rear wheels. Compartment dimensions 36" high x 64" wide by 12" deep.

L3 - One (1) full height/split depth compartment, with a roll up door, will be provided behind the rear wheels. Compartment dimensions 68" high x 46" wide x 26" deep in the lower 30" high area, 12" deep in the upper 38" high area.



OFFICER'S SIDE COMPARTMENTATION

R1 - One (1) full height/split depth compartment, with a roll up door, will be provided forward of the rear wheels. Compartment dimensions 68" high x 48" wide x 26" deep in the lower 30" high area, 12" deep in the upper 38" high area.

R2 - One (1) high side compartment, with a roll up door, will be provided above the rear wheels. Compartment dimensions 36" high x 64" wide by 12" deep.

R3 - One (1) full height/split depth compartment, with a roll up door, will be provided behind the rear wheels. Compartment dimensions 68" high x 46" wide x 26" deep in the lower 30" high area, 12" deep in the upper 38" high area.

ROLL-UP DOORS

Roll-up doors will be provided on all compartments. The roll-up doors will be constructed from aluminum extruded slats which will have a flexible seal between each slat for proper sealing of the door.

A synthetic rubber seal will be provided at each side, top and bottom edge of the door to prevent entry of dirt into the compartment.

The door will be equipped with a lift bar style latch mechanism which will latch at the bottom of the door mounting extrusion.

The roll-up door assembly will be furnished with a spring-loaded, counter balance assembly to assist in door actuation.

All running board and high side compartments will be equipped with roll-up doors.



ROM SERIES IV ROLL-UP SHUTTER DOORS - BRUSHED FINISH

R•O•M Series IV roll-up shutter doors will be installed. Each shutter slat, track, bottom rail, and drip rail shall be constructed from anodized 6063 T6 aluminum.

The Shutter slats will feature a double wall extrusion 0.315" thick with a concave interior surface to minimize loose equipment jamming the shutter door closed. The Shutter slats will feature an interlocking end shoe to prevent side to side binding of the shutter door during operation. The Slats must have interlocking joints with an inverted locking flange. The Slat inner seal will be a one piece PVC extrusion; seal design will be such to prevent metal to metal contact while minimizing dirt and water from entering the compartment.

The Shutter door track will be one piece design with integral overlapping flange to provide a clean finished look without the need of caulk. The Door track will feature an extruded Santoprene rubber double lip low profile side seal with a silicone co-extruded back to reduce friction during shutter operation.

The Shutter bottom rail will be a one piece double wall extrusion with integrated finger pull. The Finger pull will be curved upward with a linear striated surface to improve operator grip while operating the shutter door. The Bottom rail will have a smooth contoured interior surface to prevent loose equipment from jamming the shutter door. The Bottom rail seal will be made from Santoprene; it will be a double "V" seal to prevent water and debris from entering compartment. The Bottom rail lift bar will be a one piece "D" shaped aluminum extrusion with linear striations to improve operator grip during operation. The Lift bar will have a wall thickness of 0.125". The Lift bar will be supported by no less than two pivot blocks; pivot blocks will be constructed from Type 66 Glass filled reinforced nylon for superior strength. The Bottom rail end blocks will have incorporated drain holes which will allow any moisture that collects inside the extrusion to drain out.

The Shutter door will have an enclosed counter balance system. The Counter balance system will be 4" in diameter and held in place by 2 heavy duty 18 gauge zinc plated plates. The Counter balance system will have 2 over-molded rubber guide wheels to provide a smooth transition from vertical track to counter balance system; no foam material of any kind shall be permitted or used in this area.

Shutter door assembly will be manufactured and assembled in the United States, no exceptions.

The roll-up doors will be Robinson (ROM) brand roll-up doors, equipped with a brushed aluminum finish, with a PVC inner seal to prevent metal to metal contact and to repel moisture. The slats will be double-wall extrusion 1.366" high by .315" thick with interlocking end shoes to prevent the slats from moving side-to-side and binding the door. All slats are to have interlocking joints to prevent penetration by sharp objects.

UNPAINTED TOP GUTTER AND SIDE FRAMES

The top gutter and side frames will remain unpainted.

20" PULL STRAPS

20" elastic pull straps will be provided for the roll-up doors.

A total of seven (7) straps will be provided.



SWEEP-OUT COMPARTMENT FLOORS

Compartment floors will be welded to the compartment walls and have a sweep out design for easy cleaning.

Compartments with hinged doors will have the door opening flanges bend down to produce the sweep-out design.

Compartments with roll-up style doors will have the external floor flange stepped down, 1/2" high x 2" deep, to produce a sealing surface for the roll-up doors below the compartment floor. The sweep out design will also permit easy cleaning.

COMPARTMENT TOPS

The compartment tops will be painted.

COMPARTMENT DRIP MOLDING

Compartment tops over all side compartments will have a 45 degree flange formed out to provide protection against water runoff. A secondary extruded drip molding will be provided between low compartments and auxiliary high side compartments, when auxiliary compartments are provided.

COATED FASTENERS

All exterior fasteners will be coated stainless steel screws. Screw threads will be coated with reusable, self-locking, sealing material to provide vibration resistance. Screw heads will be coated with a sealing element to prevent galvanic corrosion between dissimilar metals. Non-coated screws will only be provided as part of vendor supplied component installations.

COMPARTMENT LOUVERS

Ventilation between compartments to atmosphere will be provided and located to avoid water entry into compartments.

ACCESS PANELS

Removable access panels will be provided (if applicable) to access fuel tank sender, electrical junction compartment and rear body mounts.

Protective panels will be located in the rear compartments providing access to the lights and associated wiring. The covers will also serve as protective covers to prevent inadvertent damage to lights or wiring from tools or equipment located in the compartment.

BODY PROTECTION PANELS

The front face of the side compartments, next to the driver and officer side pump panels will be overlaid with aluminum tread plate full height protection. The protection panel will cover the entire front face of the compartment and will wrap around the corner to the door opening.

REAR BODY PANEL

The rear body panel will extend the full width of the body. This panel will be full height from the rear step to the hose bed floor. The panel will be bolted on and removable, with no part of the rear panel attached to the booster tank. The rear body panel material will be aluminum tread plate as standard. If Chevron striping is specified for the rear of the body then smooth aluminum will be utilized.



BODY RUB RAILS

Sacrificial aluminum tread plate rub rails will be mounted at the base of the body, extend outward a minimum 3/4", downward 2" and flange inward 1". The rub rails will extend the full length of the main body and extend to the rear step or wrap around the rear body corners. The rub rails will be designed to provide for ease of replacement.

RUNNING BOARD STEPS

The driver and officer running board steps will be fabricated of 3/16" polished aluminum tread plate. The outside edge on each step will be fabricated with a double break, return flange. The steps will be rigidly reinforced with a heavy duty support structure. The running boards will not form any part of the compartment design and will be bolted into place with a minimum 1/2" clearance gap between any panel to facilitate water runoff.

REAR STEP

The rear step will be fabricated from 3/16" polished aluminum tread plate, and will be rigidly reinforced. The rear step will extend 12" past the rear edge of the body, and will be 100" wide with square corners.

The rear edge of the step will be designed to accommodate the rear clearance lights, recessed for protection in the step reinforcement channel. The step tread plate overlay will be bolted to the step frame for ease of replacement.

INTERMEDIATE REAR STEP

An eight (8) inch deep, bolt on intermediate rear step, fabricated from 3/16" aluminum tread plate, will be installed. The step will be approximately 8" deep x 48" wide.

REAR STEP COMPARTMENT

One (1) rear step compartment 30" high x 42" wide x 26" deep will be provided with a door opening of 27" high x 40" wide.

The rear step compartment door will be a roll-up door. The roll-up door will be equipped with a brushed aluminum finish.

GRAB RAILS

All hand rails will be 1-1/4" outer diameter, knurled bright anodized aluminum extrusion, designed to meet NFPA 1901 requirements.

Molded gaskets will be installed between the handrail stanchion castings and body surfaces to prevent electrolytic reaction between dissimilar metals and to protect paint.

GRAB RAIL LOCATIONS:

Grab rails will be provided at the following specified locations. Additional grab rails will be provided adjacent to any additional steps specified to comply with NFPA 1901.

Two (2) vertical rails will be mounted on the rear edge of the body, one (1) each side.

One (1) horizontal, full width handrail will be installed on the rear, below the level of the hose bed.



FOLDING STEP(S) - BODY FRONT DRIVER SIDE

Three (3) Innovative Controls large lighted folding step(s) (IC-3004234-33-1-1-1-1-0 LED), with a textured chrome plate finish, will be provided on driver side body front to provide NFPA compliant access (maximum 18" height between steps) to an upper horizontal walking surface (compartment cap, dunnage area, fabricated step, or upper body compartments).

FOLDING STEP(S) - BODY FRONT OFFICER SIDE

Three (3) Innovative Controls large lighted folding step(s) (IC-3004234-33-1-1-1-1-0 LED), with a textured chrome plate finish, will be provided on officer side body front to provide NFPA compliant access (maximum 18" height between steps) to an upper horizontal walking surface (compartment cap, dunnage area, fabricated step, or upper body compartments).

FOLDING STEP(S)- BODY REAR DRIVER SIDE

Three (3) Innovative Controls large lighted folding step(s) (IC-3004234-33-1-1-1-1-0 LED), with a textured chrome plate finish, will be provided on driver side body rear to provide NFPA compliant access (maximum 18" height between steps) to an upper horizontal walking surface (compartment cap, dunnage area, fabricated step, or upper body compartments).

FOLDING STEP(S)- BODY REAR OFFICER SIDE

Three (3) Innovative Controls large lighted folding step(s) (IC-3004234-33-1-1-1-1-0 LED), with a textured chrome plate finish, will be provided on officer side body rear to provide NFPA compliant access (maximum 18" height between steps) to an upper horizontal walking surface (compartment cap, dunnage area, fabricated step, or upper body compartments).

SAFETY SIGN(S) AT REAR STEP AND CROSS WALKWAY(S)

Safety sign(s) will be located on the vehicle at the rear step, and at any cross walkway(s), to warn personnel that riding in or on these areas while the vehicle is in motion is prohibited.

WELDED ALUMINUM REAR WHEEL WELL LINERS

Fully removable, 1/8" aluminum fender liners will be provided. The wheel well liners will be welded to the body and extend from the outer wheel well body panel, into the truck frame. Removable vertical splash shields, inward of the wheels, will be provided to give access to the hydraulic components. The completely washable fender liners will be designed to protect the front and rear compartments and main body supports from road salts, dirt accumulation and corrosion.

REAR FENDERETTES

The single rear fenders will be equipped with easily replaceable, polished stainless steel fenderettes. The fenderettes will be equipped with a rubber gasket molding between the body panel and the fender. Integral welded crown type liners will not be acceptable.



***** BODY FENDER STORAGE COMPARTMENTS *****

THREE (3) BOTTLE STORAGE DRIVER FRONT FENDER

A storage compartment will be inserted into the front driver side body fender. The compartment will be sized large enough to store three (3) SCBA cylinders or fire extinguishers, with a maximum length of 26". The compartment will have a non-abrasive lined floor area for the three (3) devices. The compartment will be enclosed by a hinged door with a thumb latch. The back side of the door will have a section of Nylatron installed to protect the door surface from the items stored in the compartment.

THREE (3) BOTTLE STORAGE DRIVER REAR FENDER

A storage compartment will be inserted into the rear driver side body fender. The compartment will be sized large enough to store three (3) SCBA cylinders or fire extinguishers, with a maximum length of 26". The compartment will have a non-abrasive floor area for the three (3) devices. The compartment will be enclosed by a hinged door with a thumb latch. The back side of the door will have a section of Nylatron installed to protect the door surface from the items stored in the compartment.

THREE (3) BOTTLE STORAGE OFFICER FRONT FENDER

A storage compartment will be inserted into the front officer side body fender. The compartment will be sized large enough to store three (3) SCBA cylinders or fire extinguishers, with a maximum length of 26". The compartment will have a non-abrasive floor area for the three (3) devices. The compartment will be enclosed by a hinged door with a thumb latch. The back side of the door will have a section of Nylatron installed to protect the door surface from the items stored in the compartment.

THREE (3) BOTTLE STORAGE OFFICER REAR FENDER

A storage compartment will be inserted into the rear officer side body fender. The compartment will be sized large enough to store three (3) SCBA cylinders or fire extinguishers, with a maximum length of 26". The compartment will have a non-abrasive floor area for the three (3) devices. The compartment will be enclosed by a hinged door with a thumb latch. The back side of the door will have a section of Nylatron installed to protect the door surface from the items stored in the compartment.

NYLON STRAP FOR SCBA CYLINDER(S)

Twelve (12) nylon strap will be provided, one (1) for each SCBA bottle body fender storage compartment to provide a secondary means to hold each SCBA bottle in place. The strap will be a 1" nylon webbing formed in a loop. The strap will be secured to the SCBA bottle tray and will loop around the SCBA cylinder to hold in place.

FENDER STORAGE DOOR - PAINTED

The fender storage area will be painted the primary body color.

REAR MUD FLAPS

Heavy duty mud flaps will be provided behind the rear wheels.

PAINTED REAR TOW EYES

Two (2) painted tow eyes will be furnished on the rear of the vehicle. The tow eyes will be made from plate steel and will be bolted directly to the chassis frame rails with grade 8 bolts and will extend below the body. The tow eyes will be smooth and free from sharp edges and have a minimum eyelet hole of 2-1/2". The tow eyes will be painted.



HOSE BED CAPACITY

The hose bed will be located directly above the booster tank and will be free from all sharp objects such as bolts, nuts, etc., to avoid damage to fire hose.

The hose bed will provide approximately 126 cubic feet of hose storage area for 2 ½" or larger fire hose, exceeding NFPA 1901 minimum pumper hose storage requirements. The hose bed depth will be 16".

The apparatus weight analysis will be based on 800' of 2 ½" hose unless otherwise specified. If the hose load to be carried exceeds this minimum, the purchaser must advise the manufacturer prior to contract so adequate chassis carrying capacity can be provided.

For added strength, the hose bed side walls will be 2" thick, this will provide a mounting surface for devices like warning lights and scene lights. The inner hose bed side walls will be brushed aluminum panels, which will prevent damage to painted surfaces when deploying hose. The front and side walls on the hose bed will be constructed of a combination of two inch rounded structural thick wall square tubing and two inch square aluminum extrusion depending on body design requirements.

HOSE BED FLOORING

Flooring to be constructed from extruded aluminum and be properly spaced for ventilation. The flooring will be smooth and free from sharp edges to avoid hose damage. The hose bed floor will be removable to provide access to inner body framework.

TWO (2) HOSE BED PARTITIONS

Two (2) fully adjustable 3/16", brushed finish, aluminum hose bed partitions will be provided. The partitions will be easily adjustable by means of Unistrut channels located at the front and rear of the hose bed.

HOSE BED COVER, VINYL WITH VELCRO

A hose bed cover will be provided and installed. The cover will be made from 22 ounce; heavy-duty vinyl coated polyester fabric (TXN 226). The cover will be sewn with ultraviolet resistant thread and will have 2" wide nylon webbing sewn around the perimeter to provide additional strength.

The cover will be secured to the top front body flange with Velcro and quarter turn fasteners and will be secured to the top side body flanges with Velcro. A weighted flap will be furnished on the rear of the cover with two (2) bungee cords.

The Hypalon material will be red in color.



LADDER STORAGE - OFFICER'S SIDE OF WATER TANK

The ground ladders will be stored vertically next to the water tank, behind the side body compartments, on the officer side of the apparatus.

To secure the ground ladders, a hinged rear access door will be provided and tied into the "Do Not Move Apparatus" warning system.

A hinged rear access door with d-ring latch will be provided on the rear of the body to access the ladder storage. The door will be tied into the "Do Not Move Apparatus" warning system.

A hinged rear access door will be finished with smooth aluminum with chevron to match the rear chevron on the rear of the body.

GROUND LADDERS

The following Alco-Lite ground ladder complement will be provided:

- One (1) Alco-Lite model PEL-24; 24', aluminum, two (2) section extension ladder will be provided.
- One (1) Alco-Lite model PRL-14; 14', aluminum, straight roof ladder with folding hooks will be provided.
- One (1) Alco-Lite model FL-10; 10', folding, aluminum, attic ladder will be provided.

PIKE POLE STORAGE

Two (2) pike pole tube(s) will be provided. Each holder will be accessible from the rear of the apparatus. Each pike pole holder will be labeled to indicate the pike pole length.

The pike pole tube(s) will be mounted in the ladder storage compartment built in to the body.

SUCTION HOSE STORAGE - DRIVER & OFFICER SIDE BEHIND ROLL UP DOOR

The suction hoses will be located one (1) on the driver's side and one (1) on the officer's side between the water tank and compartments behind the roll up the door. The hose storage area will be accessed from the rear of the apparatus. The storage area will be enclosed with a hinged door on the rear of the body.

A hinged rear access door with d-ring latch will be provided on the rear of the body to access the suction hose storage. The door will be tied into the "Do Not Move Apparatus" warning system.

The hinged rear access door will be finished with smooth aluminum with chevron to match the rear chevron on the rear of the body.

SUCTION HOSE

Two (2) 10' sections of six (6) inch Kochek (PVC) suction hose with lightweight hard coat couplings will be furnished, 2P601-10-A52. Couplings will include a long handle, female swivel on one end and a rocker lug male on the other end. All threads will be six (6) inch N.S.T.

NOTE: All PVC suction hoses are strictly drafting hoses and must not be used on hydrants or in pressure applications, as serious personal injury or death may occur.



EQUIPMENT CLARIFICATION

The NFPA-1901 required suction strainer will "NOT" be provided by the apparatus manufacturer.

EQUIPMENT CLARIFICATION

The NFPA-1901 recommended double female hydrant adapter will not be provided by the apparatus manufacturer.

ADDITIONAL ITEMS SUPPLIED WITH THE VEHICLE

- 1 - Pint of touch up paint for each color
- 1 -Bag of assorted stainless steel nuts and bolts

WHEEL CHOCKS

Two (2) ZICO #SAC-44-E folding wheel chocks will be mounted forward of the rear wheels on the driver side below the side running board compartments.



PAINT, PREPARATION AND FINISH

The apparatus body will be painted Sikkens [#COL]. The paint process will meet or exceed current state regulations concerning paint operations. Pollution control will include measures to protect the atmosphere, water, and soil. Contractor will, upon demand, provide evidence that the manufacturing facility is in compliance with State EPA rules and regulations.

The exterior will have no mounted components prior to painting to assure full coverage of metal treatments and paint to the exterior surfaces of the body. Any vertically or horizontally hinged smooth-plate compartment doors will be painted separately to assure proper paint coverage on body, door jambs and door edges.

Paint process will feature Sikkens high solid LV products and be performed in the following steps:

- Corrosion Prevention - all aluminum surfaces will be pre-treated with the Alodine 5700 conversion coating to provide superior corrosion resistance and excellent adhesion of the base coat.
- Sikkens Sealer/Primer LV - acrylic urethane sealer/primer will be applied to guarantee excellent gloss hold-out, chip resistance and a uniform base color.
- Sikkens High Solid LVBT650 (Base coat) - a lead-free, chromate-free high solid acrylic urethane base coat will be applied, providing excellent coverage and durability. A minimum of two (2) coats will be applied.
- Sikkens High Solid LVBT650 (Clear coat) - high solid LV clear coat will be applied as the final step in order to ensure full gloss and color retention and durability. A minimum of two (2) coats will be applied.

Any location where the material is penetrated after painting, for the purpose of mounting steps, hand rails, doors, lights, or other specified components will be treated at the point of penetration with a corrosion inhibiting pre-treatment (ECK Corrosion Control). The pre-treatment will be applied to the aluminum sheet metal or aluminum extrusions in all locations where the aluminum has been penetrated. All hardware used in mounting steps, hand rails, doors, lights, or other specified components will be individually treated with the corrosion inhibiting pre-treatment.

After the paint process is complete, the gloss rating of the unit will be tested with a 20 degree gloss meter. Coating thickness will be measured with a digital MIL gauge and the orange peel with a digital wave scan device.

BODY PRIMER & PREPARATION

All exposed welds will be ground smooth for final finishing of areas to be painted. The compartments and doors are totally degreased and phosphatized. After final body work is completed, grinding (36 and 80 grit), and finish sanding will be used in preparation for priming.

BODY FINISH PAINT

The body will be finish sanded and prepared for final paint. Upon completion of final preparation, the body will be painted utilizing the highest quality, state of the art, low V.O.C., polyurethane base paint. Finish paint will be applied in multiple coats to ensure proper paint coverage with a high gloss finish.

The entire body will be buffed and detailed.

UNDERBODY BODY PAINT

The inside and underside areas of the complete body assembly will be painted black using a Sikkens paint system, prior to the installation of the body on the chassis.



GRAY ZOLATONE COMPARTMENT PAINT

The interior of the compartments will be finish painted with gray Zolatone scuff resistant paint to provide a protective application over all of the compartment interior surfaces.

FENDER STORAGE COMPARTMENTS - GRAY ZOLATONE

The interior of the fender storage compartments (if fender compartments are specified) will be finish painted with gray Zolatone finish to provide a protective finish.

SINGLE COLOR BODY PAINT

The body paint finish will be Sikkens paint system in a single color, to match customer furnished paint codes and requirements.

SINGLE COLOR CHASSIS CAB PAINT

The commercial cab exterior will be finish painted in a single color by the chassis manufacturer with Purchaser's choice of color as available.

COMMERCIAL CAB PAINT FINISH GUIDELINES

The chassis will be painted and detailed as provided from the chassis OEM and will meet their quality guidelines.

WHEEL PAINT

The chassis wheels will be painted as provided by the commercial chassis manufacturer.

TOUCH-UP PAINT

One (1) pint of each exterior color paint for touch-up purposes will be supplied when the apparatus is delivered to the end user.

FINALIZATION & DETAILING

Prior to delivery of the vehicle, the interior and exterior be cleaned and detailed. The finalization process detailing will include installation of NFPA required labels, checking fluid levels, sealing and caulking required areas of the cab and body, rust proofing, paint touch-up, etc.

UNDERBODY ANTI-CORROSION PAINT TREATMENT

Upon completion, the underside of the apparatus, from the pump enclosure-back, will have anti-corrosion textured paint applied to help inhibit rust and the corrosion process. The Quick Dry Rubberized undercoat paint will be applied using an air driven spray gun. The paint will be applied as a minimum to the following areas: body substructure, underside of all body compartments, running board supports and rear step supports. No paint will be applied directly to the exhaust system or wheel wells.



****** LETTERING AND STRIPING ******

COMPUTER GENERATED LETTERING

The lettering and striping will be custom designed utilizing state of the art computer software and computerized cutting machines. The manufacturer will employ a full time artist / designer to generate all lettering, decals, and striping to meet the requirements of the Fire Department. The artwork for the lettering and striping will be kept on record by the apparatus manufacturer to allow for ease in duplication for the Fire Department.

******NFPA REQUIRED SCOTCH-LITE STRIPING ******

SCOTCH-LITE STRIPE

A four (4) inch high "Scotch-Lite" stripe will be provided. The stripe will be applied on a minimum of 60 percent of each side of the unit, 60 percent on the rear of the unit and 40 percent on the front of the unit. The Scotch-Lite stripe layout will be determined by the Fire Department.

The Scotch-Lite will be white in color.

REAR CHEVRON STRIPING

At least 50% of the rear facing vertical surface will be covered with alternating strips of reflective striping.

The striping will be 6" Scotch-Lite.

The Scotch-Lite will be Ruby Red and Yellow in color.



FES WARRANTY, STARTING ON IN-SERVICE DATE

Warranty coverage by FES will begin when the customer places the unit in service. This date may not exceed 60 days from the date of delivery to the customer.

The Customer must email feswarranty@safeindustries.com within 60 days of delivery, or the warranty start date will default to the original delivery date.

ONE (1) YEAR - NEW PRODUCT MATERIAL AND WORKMANSHIP WARRANTY

FES (the "Company") warrants each new item of fire and rescue apparatus manufactured by it against defects in material and workmanship provided the apparatus is used in a normal and reasonable manner. This warranty is extended only to the original user-purchaser for a period of one year from the date of delivery to the original user-purchaser.

FES's obligation under this warranty is strictly limited to replacing or repairing, as the Company may elect, any part or parts of such apparatus which the Company's examination discloses to be defective in material or workmanship.

The Company reserves the right to require any such repairs to be made either at a Company owned service facility or another approved service facility at the Company's option. Transportation cost to and from the servicing location is the responsibility of the user-purchaser.

The FES warranty shall not apply to:

- Major components or trade accessories such as purchased chassis, engines, transmissions, tires, pumps, signaling devices, or batteries that have a separate warranty by the original manufacturer or to ancillary equipment used in fire fighting.
- Normal adjustments and maintenance services.
- Replacement of consumable parts including, but not limited to; filters, lubricants, belts, light bulbs, wiper blades, brake linings and brake pads.
- Failure resulting from the apparatus being operated in a manner or for a purpose not recommended by FES.
- Any apparatus, which shall have been repaired, modified or altered in any way so as, in the Company's sole judgment, to have adversely affected the unit's stability or reliability.
- Items subjected to misuse, negligence, accident or improper maintenance.
- Loss of time or use of the vehicle, inconvenience or other incidental expenses.

Nothing contained in this warranty shall make FES liable beyond the express limitations hereof, for loss, injury or damage of any kind to any person or entity resulting from any defect or failure in this vehicle.

To the extent permitted by law, THIS WARRANTY IS IN LIEU OF ALL OTHER WARRANTIES, EXPRESS OR IMPLIED, INCLUDING WITHOUT LIMITATION, ANY IMPLIED WARRANTIES OF MERCHANTABILITY AND FITNESS FOR A PARTICULAR PURPOSE.

To the extent permitted by law, this warranty is also in lieu of all other obligations or liabilities on the part of FES or the Seller, including liability for incidental and consequential damages.



ONE (1) YEAR - NEW PRODUCT MATERIAL AND WORKMANSHIP WARRANTY, CONT'D.

FES makes no representation that the vehicle has the capacity to perform any functions other than as contained in the Company's written literature, catalogs or specifications accompanying delivery of the vehicle.

No person or affiliated Company representative is authorized to give any other warranties or to assume any other liability on behalf of FES in connection with sale, service or repair of any apparatus manufactured by the Company.

FES reserves the right to make design changes or improvements in its products without imposing any obligation upon itself to change or improve previously manufactured products.

Whenever a performance bond is required under a contract or purchase order, coverage under the performance bond shall only extend for one year from the delivery date of the equipment. This limitation under the performance bond shall not affect any extended warranties offered by FES or any OEM's.

TEN (10) YEAR BODY STRUCTURE WARRANTY

The proposed body will be warranted against structural defects for a period of ten (10) years from the date of acceptance of the unit. Details of warranty coverage, limitations and exclusions are included in the specific warranty document.

TEN (10) YEAR CORROSION WARRANTY

The proposed body will be warranted against rust-through or perforation, due to corrosion from within, for a period of ten (10) years. Perforation is defined as a condition in which an actual hole occurs in a sheet metal panel due to rust or corrosion from within. Surface rust or corrosion caused by chips or scratches in the paint is not covered by this warranty.

SEVEN (7) YEAR PAINT WARRANTY

The proposed paint finish will be warranted for a period of seven (7) years from the date of acceptance of the unit. Details of warranty coverage, limitations and exclusions are included in the specific warranty document.

FIVE (5) YEAR LETTERING WARRANTY

Fire Equipment Sales and Services (FES) shall provide a five (5) year warranty against defects in material and workmanship for all graphic processes. Any valid claims must be made in writing within 15 days of the determination of any defects to FES. FES will at its option make any necessary repairs either at a local authorized service center or at the factory, if required. FES will make the final decision as to where the repairs are to be made and any transportation cost are the owners responsibility, FES will at its option repair or replace any verified defects in workmanship or materials at no cost to the owner provided all the requirements of this warranty have been met.

FES shall not be liable to the original purchaser or anyone else for consequential, incidental, special or direct damages, including, but not limited to, any claims for loss of profits, down time, loss of use or inconvenience. THE COMPANY MAKES NO OTHER WARRANTY, EXPRESSED OR IMPLIED, AND SPECIFICALLY, DISCLAIMS ANY IMPLIED WARRANTY INCLUDING THE WARRANTY OF MERCHANTABILITY.

FES continually strives to improve its products and therefore, reserves the right to make improvements or changes without incurring any obligations to make such changes or additions on equipment previously sold.



ONE (1) YEAR BRIGHTWORK WARRANTY

Fire Equipment Sales and Services (FES) warrants all bright finish components used in the construction of FES Apparatus against defects and workmanship provided the apparatus is used in a normal and reasonable manner. This warranty is extended only to the original user-purchaser for a period of one (1) year from the date of delivery / acceptance to the original user-purchaser, whichever occurs first.

The expressed warranty excludes corrosion or degradation of bright finished components caused by damage to the component.

TEN (10) YEAR STAINLESS STEEL PLUMBING WARRANTY

The proposed stainless steel plumbing will be warranted for a period of ten (10) years from the date of acceptance of the unit. Details of warranty coverage, limitations and exclusions are included in the specific warranty document.

LIFETIME WATER TANK WARRANTY

The proposed water tank will be warranted by the water tank manufacturer for the "Lifetime" of the unit. A copy of the manufacturer's warranty will be supplied to define additional details of the warranty provisions.

STANDARD HALE FIRE PUMP WARRANTY

Hale Products, Incorporated ("Hale") hereby warrants to the original buyer that products manufactured by Hale will be free of defects in material and workmanship for a period of five (5) years from the date product is first placed into service or five and one-half (5 1/2) years from date of shipment by Hale, whichever period will be first to expire. Within this warranty period Hale will cover parts and labor for the first two (2) years and parts only for years three (3) through five (5).

AKRON HEAVY DUTY VALVES WARRANTY

Akron Brass warrants Heavy Duty Swing-Out Valves for a period of ten (10) years after purchase against defects in material or workmanship. Akron Brass will repair or replace any Heavy Duty Swing Out Valve which fails to satisfy this warranty.