

CURBTENDER TOMCAT SATELLITE STANDARD FEATURES

6 YD BODY CAPACITY

SATELLITE REAR LIFT ASSEMBLY

HOPPER DOORS

AUTO TAILGATE LOCKS

ANTI-SAIL MUD FLAPS AHEAD OF REAR AXLE

FULL EJECT

HOT SHIFT PTO, DM PUMP, W/ OVERSPEED PROTECTION

ALL LED BODY LIGHTS

DUAL PTO SHUT-OFF SWITCHES

COLOR LCD REAR VISION CAMERA SYSTEM

FACTORY MOUNTING

FACTORY PAINTING- PERFORMANCE WHITE

DELIVERY ANYWHERE IN NC

1 YEAR BODY & HYDRAULIC WARRANTY

1 YEAR CYLINDER WARRANTY

\$99,930.00

TOMCAT

Satellite Transfer Model



CURBTENDER

www.curbtender.com

TOMCAT

Satellite Transfer Model

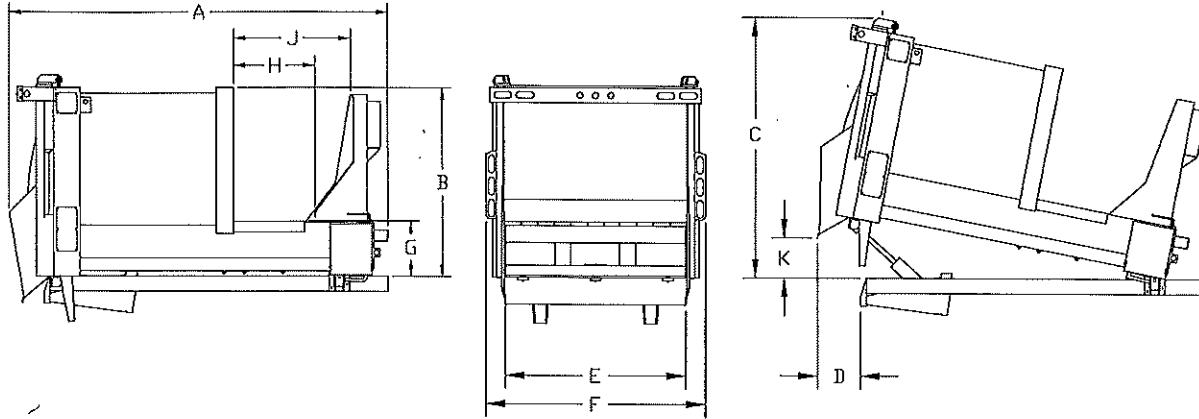

Body Specifications	Satellite Dump			Flat TG, Rigid Mount	
	6 CU. YD.	10 CU. YD.	14 CU. YD.	6 CU. YD.	10CU. YD
A LENGTH OF BODY	148"	166"	197"	148"	166"
B HEIGHT ABOVE CHASSIS FRAME	75"	88"	88"	75"	88"
C HEIGHT ABOVE CHASSIS FRAME, TRANSFER MODE	110"	113"	113"	-	-
D BODY HORIZONTAL CLEARANCE, TRANSFER MODE	16"	17"	17"	-	-
E WIDTH OF TAILGATE	69 1/2"	69 1/2"	69 1/2"	69 1/2"	69 1/2"
F WIDTH OF BODY	79"	82"	82"	79"	82"
G LOADING SILL HEIGHT ABOVE CHASSIS FRAME	23"	23"	23"	21"	21"
H LOADING AREA WIDTH	31"	31"	31"	31"	31"
J TOP OF HOPPER OPENING OFF FRAME	46"	46"	46"	46"	46"
K BODY CLEARANCE ABOVE FRAME, TRANSFER MODE	15"	13"	13"	-	-
- BODY WEIGHT	5,100 LBS	6,700 LBS	7,150 LBS	5,100 LBS	6,700 LBS
- DYNAMIC HOPPER CAPACITY	4 CU. YD.	4 CU. YD.	4 CU. YD.	4 CU. YD.	4 CU. YD.
- PRACTICAL FILLABLE LOADING VOLUME	1 CU. YD.	1 CU. YD.	1 CU. YD.	1 CU. YD.	1 CU. YD.

Minimum Chassis Requirements

- Minimum CGWR	17,950 LBS	23,500 LBS	30,000 LBS	17,950 LBS	23,000 LBS
- FRONT AXLE	6,830 LBS	8,000 LBS	10,000 LBS	6,830 LBS	8,000 LBS
- REAR AXLE	12,980 LBS	15,500 LBS	20,000 LBS	12,980 LBS	15,500 LBS
- CAB TO AXLE	84"	108"	138"	102"	120"
- FRAME HEIGHT	30" TO 37.5"	34" TO 37.5"	34" TO 37.5"	30" TO 37.5"	34" TO 37.5"

Features

- Satellite Dump into Rear Loader
- Flat, Sliding Tailgate
- Chiseled Body Shell Design
- Ultra-High Strength-to-Weight Ratio
- Low Loading Sill Height
- Ambidextrous Loading Sills
- 14-16 Second Packing Cycle Time
- Standard 8" Side Doors
- No-Fallback Design
- Extra Large Hopper Clean-Out Doors
- Single Piece Formed AR450 Body Floor

Hydraulic System

- Pump - Vane Type
- Capacity: 12 GPM @ 1,200 RPM
- Maximum Operation Pressure: 3,000 PSI
- 12 gallons Hydraulic Tank
- Sight Gauge on Tank
- 10 Micron Return Line Filter with By-pass Valve

Body Construction

- Sides: 11 gauge GR50
- Roof: 11 gauge GR50
- Floor: 3/16" AR450
- Packer Face Panel: 3/8" 50,000 PSI

Optional Equipment

- Strobe Lights & Beacons
- Cart Tipplers
- Hopper Cover
- Work Lights
- Upper Hopper Doors

CURBTENDER
www.curbtender.com

701 PERFORMANCE DRIVE, CEDAR FALLS, IA 50613
PHONE: 319.266.1721, FAX: 319.266.8207

© 2017 Curbtender Inc., All Rights Reserved. Specifications subject to change.