

CURBTENDER TOMCAT STANDARD FEATURES

6 YD BODY CAPACITY

HOPPER DOORS

AUTO TAILGATE LOCKS

ANTI-SAIL MUD FLAPS AHEAD OF REAR AXLE

FULL EJECT

HOT SHIFT PTO, DM PUMP, W/ OVERSPEED PROTECTION

ALL LED BODY LIGHTS

DUAL PTO SHUT-OFF SWITCHES

COLOR LCD REAR VISION CAMERA SYSTEM

FACTORY MOUNTING

FACTORY PAINTING- PERFORMANCE WHITE

DELIVERY ANYWHERE IN NC

1 YEAR BODY & HYDRAULIC WARRANTY

1 YEAR CYLINDER WARRANTY

\$96,943.00

TOMCAT

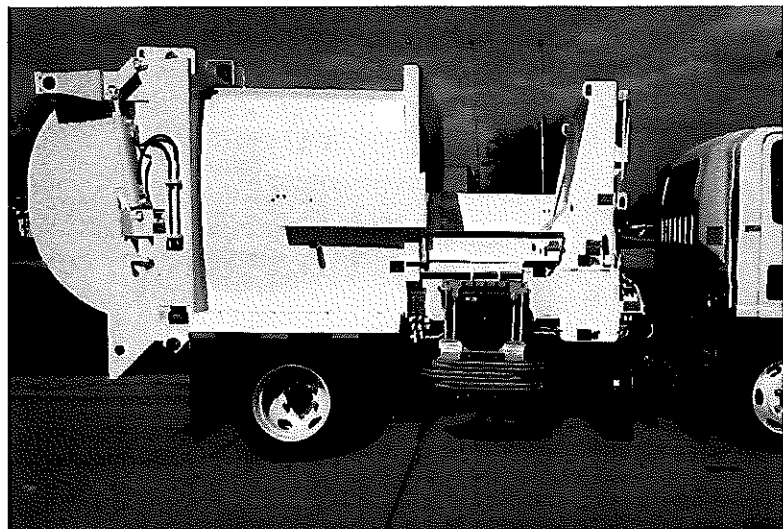

CURBTENDER

www.curbtender.com

TOMCAT

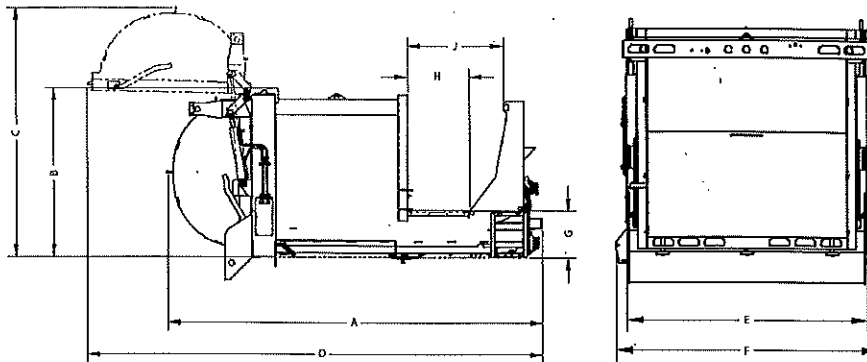

Body Specifications	8 CU. YD.	11 CU. YD.	12 CU. YD.	13 CU. YD.	14 CU. YD.	16 CU. YD.	17 CU. YD.	18 CU. YD.
A LENGTH OF BODY	169"	178"	178"	196"	196"	210"	228"	228"
B HEIGHT ABOVE CHASSIS FRAME	75"	88"	88"	88"	88"	88"	88"	88"
C HEIGHT ABOVE CHASSIS FRAME, TAIL GATE RAISED	110"	119"	119"	137"	137"	119"	137"	137"
D LENGTH OF BODY, TAIL GATE RAISED	205"	236"	236"	250"	250"	268"	282"	282"
E WIDTH OF BODY	80"	83"	83"	83"	83"	83"	83"	83"
F WIDTH OF FENDERS	85",92",96"	85",92",96"	85",92",96"	85",92",96"	85",92",96"	85",92",96"	85",92",96"	85",92",96"
G LOADING SILL HEIGHT ABOVE CHASSIS FRAME	21"	21"	21"	21"	21"	21"	21"	21"
H LOADING AREA WIDTH	31"	46"	31"	46"	31"	46"	46"	31"
J TOP OF HOPPER OPENING OFF FRAME	46"	61"	46"	61"	46"	61"	46"	46"
BODY WEIGHT	5,100 LBS	6,400 LBS	6,400 LBS	6,480 LBS	6,480 LBS	7,520 LBS	7,600 LBS	7,600 LBS
DYNAMIC HOPPER CAPACITY	4 CU. YD.	6 CU. YD.	4 CU. YD.	6 CU. YD.	4 CU. YD.	4 CU. YD.	6 CU. YD.	4 CU. YD.
PRACTICAL FILLABLE LOADING VOLUME	1 CU. YD.	1.5 CU. YD.	1 CU. YD.	1.5 CU. YD.	1 CU. YD.	1 CU. YD.	1.5 CU. YD.	1 CU. YD.

Minimum Chassis Requirements

Minimum CGWR	19,500 LBS	26,000 LBS	26,000 LBS	27,500 LBS	27,500 LBS	29,000 LBS	31,000 LBS	31,000 LBS
FRONT AXLE	7,250 LBS	10,000 LBS	10,000 LBS	10,000 LBS	10,000 LBS	10,000 LBS	10,000 LBS	10,000 LBS
REAR AXLE	13,650 LBS	16,000 LBS	16,000 LBS	17,500 LBS	17,500 LBS	19,000 LBS	21,000 LBS	21,000 LBS
CAB TO AXLE	102"	120"	120"	120"	120"	152"	152"	152"
REQUIRED FRAME HEIGHT	36" TO 37.5"	34" TO 37.5"	34" TO 37.5"	34" TO 37.5"	34" TO 37.5"	34" TO 37.5"	34" TO 37.5"	34" TO 37.5"

Features

- Chiseled Shell Design: Ultra-high strength-to-weight ratio.
- Low loading sill height
- Ambidextrous loading sills
- One-piece formed Hardox body floor
- 14-16 second packing cycle times
- Standard 8" side doors
- No-Fallback design
- Clean-out tray and doors both sides

Hydraulic Cylinders

- All Cylinders double acting
- Pack (2) 3" diameter
- Eject
- TC8 - 2.5" diameter
- TC11 to 18 - 3.5" diameter
- Tailgate (2) 3" diameter cylinders

Pump

- Vane type
- Capacity: 12 GPM @ 1,200 RPM
- Maximum operation pressure: 3,000 PSI

Hydraulic tank

- Capacity: 12 gallons
- Location: upper front
- Sight gauge: on tank
- Filter: 10 micron return line filter with by-pass valve

Body Construction

- Sides: 11 gauge GR50
- Roof: 11 gauge GR50
- Floor: 3/16" Hardox
- Packer Face Panel: 3/8" 50,000 PSI

Optional Equipment

- Strobe lights & Work Lights
- Cart tippers
- Hopper cover
- Upper hopper doors
- Split body (available in 8, 12, 14, 18 CU. YD.)

CURBTENDER
www.curbtender.com

701 PERFORMANCE DRIVE, CEDAR FALLS, IA 50613
PHONE: 319.266.1721, FAX: 319.266.8207

© 2017 Curbtender Inc., All Rights Reserved. Specifications subject to change.