

**MDG75DF4 | 4.5 L | 75 kVA**

MOBILE DIESEL GENERATOR SET

EPA Emissions Certification: Tier 4 Final



**Standby Power Rating**

68 kW, 85 kVA, 60 Hz

**Prime Power Rating**

60 kW, 75 kVA, 60 Hz



Image used for illustration purposes only



\*Assembled in the USA using domestic and foreign parts

**Codes and Standards**

Generac Mobile products are designed to the following standards:



CSA CERTIFIED



NATM



TIER 4 FINAL EMISSIONS



UN31 A, UL142, ULC-S601 CERTIFIED

**Power When and Where You Need It**

Generac Mobile diesel generators are designed and engineered to power a variety of projects, in the most extreme environments. Gensets are configured to meet customer needs, including choice of containment, cold weather packages, trailer options, and more.

Generac Mobile diesel generators are manufactured to deliver reliable power, when and where you need it.

# MDG75DF4 | 4.5 L | 75 kVA

## MOBILE DIESEL GENERATOR SET

EPA Emissions Certification: Tier 4 Final

### STANDARD FEATURES

#### ENGINE SYSTEM

- John Deere® 4045HFG04
- 4 Cylinder
- Turbocharged & Aftercooled
- 275 in<sup>3</sup> (4.5 L) Displacement
- EPA Tier 4 Final
- Power @ 1,800 rpm – hp (kW):
  - Prime: 97 (73)
  - Standby: 107 (80)
- Paper Element Air Filter
- Electronic Isochronous Governing
- Variable Speed Fan
- One Spin-on Cartridge Oil Filter
- Oil Drain Extension
- One CCV System Filter
- One Fuel/Water Separator-Filter
- One Fuel Filter
- One 12 V, 720 CCA Wet Cell Battery

#### COOLING SYSTEM

- Capable of operating at 107° F (41.7° C) Ambient
- 50/50 Coolant (50% Ethylene Glycol)
- Coolant Drain Extension

#### FUEL SYSTEM

- Single Wall Fuel Tank
- Fuel tank capacity – gal (L):
  - Total: 165 (625)
  - Usable: 146 (552)
- Maximum Run Time @ 75% Load: 39 hr

- DEF Tank Capacity – gal (L):
  - Total: 12 (45.4)
  - Usable: 9.1 (34.4)
- Padlockable Fuel and DEF Tank Caps

#### CONTROL SYSTEM

- Deep Sea Electronics® 7310 MKII Controller
- 3-Position Voltage Selection Switch
- 300 A Main Circuit Breaker (MCB), Manual
- Individual Convenience Receptacle Circuit Breakers
- Emergency Stop Switch
- Remote 2-wire Start/Stop Contacts

#### ALTERNATOR SYSTEM

- 60 Hz Engine-Drive Alternator
- Standard Alternator
  - Brushless
  - 4-pole
  - 2/3 Pitch
  - Class H insulation
  - Corrosion Protection
- Marathon Electric® PM500 AVR
- Shunt Excitation System

#### POWER DISTRIBUTION

- Connection Lugs
- Convenience Receptacles
  - Two 120 V, 20 A, GFCE Duplex Receptacles (NEMA 5-20R)
  - Three 120/240 V, 50 A, 3 Pole, 4 Wire Twist-lock Receptacles (CS6369)

#### ENCLOSURE

- Aluminum, Sound Attenuated Enclosure, Insulated and Baffled
- UV and Fade Resistant, High Temperature Cured, White Polyester Powder Paint
- Central Lifting Point
- Fully Lockable Enclosure
- Multi-lingual Operating and Safety Decals
- Document Holder with Owner's Manual – Includes AC and DC Wiring Diagrams

#### TRAILER

- Hydraulic Surge Brakes
- 3 in (76.2 mm) Pintle Ring, Adjustable
- Single 6,000 lb (2,722 kg) Axle
- 15 in. Tires, Tubeless, 10 ply
- Heavy Duty Trailer Jack
- Safety Chains with Spring Loaded Safety Hooks
- Transportation Tie Downs
- Plug Adapter, Round 7 Blade (SAE J2863)
- DOT Approved Tail, Side, Brake, and Directional Lights

#### WARRANTY

- 2 Year Limited or 2,000 Hours
  - Unlimited Hours Covered in First Year

#### CONTROL SYSTEM



010643

#### Deep Sea Electronics® CONTROLLER AND DISPLAY

- Model DSE7310 MKII
- 4 Line Back Lit LCD Text Display
- -40 to 158 °F (-40 to 70 °C) Operating Temperature Range
- Multiple Language Options
- Configurable Timers and Alarms
- Configurable Start/Stop Timers

- Configurable Maintenance Alarms
- Heated Display

#### PUSH BUTTONS FOR EASY OPERATION

- Manual or Auto Start
- Engine Start
- Engine Stop/Reset
- User Friendly Setup and Button Layout
- Five Key Menu Navigation
- Hours Counter
- Multiple Parameters are Monitored and Displayed Simultaneously for Full Visibility
- View Controller Parameters (Configuration, Firmware Version, Connections)

#### LCD ALARM INDICATION

- Generator Diagnostic Display
  - System kVA Output Display
  - Line Output and Frequency Display
- Alarm Types: Warning, Shutdown, Electrical Trip, Engine
- Alarm List – Warnings/Shutdowns; 250 Event History Log – Date/Time Stamped
  - Fuel Level: Warning – 15%; Shutdown – 5%

- Overspeed Protection: Shutdown – 110%
- Engine Diagnostic Warnings Communicated Through J1939 CANbus
- Battery Voltage: Over – 15 VDC; Under – 11 VDC
- Generator Over Voltage: Warning – 110%; Electrical Trip – 115%
- Generator Under Voltage: Warning – 90%; Shutdown – 85%
- Generator Over Frequency: Warning – 105%; Electrical Trip – 110%
- Generator Under Frequency: Warning – 95%; Electrical Trip – 90%
- Auto Schedule
- Status

#### ELECTRICAL CONTROLS

- Lockable control box door with diagnostics window
- Lockable lug box with safety switch
  - Trips main breaker when door is opened
  - Disables voltage regulator
- Output ground connection lug inside lug box
- Voltage adjustment ±10%

# MDG75DF4 | 4.5 L | 75 kVA

## MOBILE DIESEL GENERATOR SET

EPA Emissions Certification: Tier 4 Final

# GENERAC® | MOBILE

### CONFIGURABLE OPTIONS\*

#### ENGINE SYSTEM

- Positive Air Shutdown (PAS), Electronic
- Oil Evacuation System - requires customer-sourced, specialized equipment to use for oil change

#### COLD WEATHER

- Engine Block Heater - included with selection of any other CW heater option
- Two Fuel Filter Heaters
- Oil Heater
- Crankcase Ventilation (CCV) System Heater
- Battery Heater
- 10 A Battery Charger
- 60/40 Coolant (60% Ethylene Glycol)

#### FUEL SYSTEM

- Containment Pan - for use with standard single wall fuel tank
  - 110% Containment - engine fluid (oil, coolant, & DEF) and fuel
- Double Wall Fuel Tank
  - 110% Containment - engine fluid (oil, coolant, & DEF) and fuel
  - UN31A Certification
  - UL142/ULC-S601 Certification

- Fuel Tank Capacity - gal (L)
  - Total: 128 (485)
  - Usable: 120 (454)
- Runtime @ 75% load: 32 hr
- Engine Fluid & Fuel Leak Detection Sensor - option available only with selection of double wall fuel tank option

#### CONTROL SYSTEM

- 4-Position Voltage Selection Switch
- Paralleling Capability
  - Deep Sea Electronics® 8610 MKII Controller
  - 300 A Main Circuit Breaker (MCB), Motorized
  - Mobile Switching Center (MSC) Cable Connections
- Telemetry
- Lojack Equipment Recovery System
- Battery Disconnect Switch

#### ALTERNATOR SYSTEM

- SUPERSTART® Alternator
- VFLEX (600V) Alternator
- Marathon Electric® DVR2400 DVR
- Permanent Magnet Generator (PMG) Excitation System

#### POWER DISTRIBUTION

- Camlocks - one set, female (US or Canada color code)
- Buck Transformer

#### ENCLOSURE

- Control Panel Lights
- Interior Lights
- Fire Extinguisher

#### TRAILER

- Skid Mount (Non-trailer)
- Electric Brakes
- Tandem Axle
- 2-5/16 in. (58.7 mm) Ball Hitch, Adjustable
- 2 in. (50.8 mm) Ball Hitch, Adjustable
- Rear Stabilizer Jacks
- Toolbox Aluminum, 49 x 15 x 18.5 in. (125 x 38 x 47 cm)
- Spare Tire

### RATING DEFINITIONS

*Standby:* Applies to varying emergency load for the duration of a utility power outage.

*Prime:* Applies to supplying power to a varying load in lieu of utility for an unlimited amount of running time.

\*Consult factory for availability.



# MDG75DF4 | 4.5 L | 75 kVA

## MOBILE DIESEL GENERATOR SET

EPA Emissions Certification: Tier 4 Final



### APPLICATION AND ENGINEERING DATA

#### ENGINE SPECIFICATIONS

##### General

Make (Model)	John Deere (4045HFG04)
EPA Emissions Compliance	Tier 4 Final
After Treatment System	DOC and SCR
Cylinders – Qty	4
Type	In-Line
Displacement – in <sup>3</sup> (L)	275 (4.5)
Bore – in (cm)	4.2 (10.6)
Stroke – in (cm)	5.0 (12.7)
Compression Ratio	17:1
Intake Air Method	Turbocharged & Aftercooled

##### Engine Governing

Governor	Electronic
Frequency Regulation (Steady State)	2%

##### Lubrication System

Oil Pump Type	Gear
Oil Filter Type	Spin-On Cartridge
Crankcase Capacity – qt (L)	15.9 (15)

##### Cooling System

Cooling System Type	Radiator and CAC
Water Pump Type	Engine Belt Driven
Fan Type	Pusher
Fan Speed – rpm	Variable Speed Clutch
Fan Diameter – in (cm)	23.2 (59.0)
Cooling System Capacity – qt (L)	22 (20.8)

##### Fuel System

Fuel Type	Ultra Low Sulfur Diesel
Fuel Specifications	EN590 / ASTM D975
Fuel Filtering – $\mu$	Primary: 10 Secondary: 2
Fuel Inject Pump – Make (Model)	Denso (HP3)
Fuel Pump Type	Engine Gear Driven
Injector Type	Electronic
Engine Type	Direct Injection High Pressure Common Rail
Fuel Supply Line Diameter – in (mm)	0.375 (9.5)
Fuel Return Line Diameter – in (mm)	0.375 (9.5)

##### Engine Electrical System

System Voltage – VDC	12
Battery Charger Alternator – VDC (A)	12 (90)
Battery – CCA	720
Battery – V (Qty)	12 (1)
Ground Polarity	Negative (-)

#### STANDARD ALTERNATOR SPECIFICATIONS

Make (Model)	Marathon Electric (361PSL1647)
Poles – Qty	4
Field Type	Rotating
Insulation Class – Rotor	H
Insulation Class – Stator	H
Total Harmonic Distortion	<3.5%
Telephone Interference Factor	<50

Standard Excitation	Shunt
Bearings	Single Bearing
Coupling	Direct Flexible Disc
Prototype Short Circuit Test	Yes
Voltage Regulator Type	AVR
Quantity of Sensed Phases	1
Regulation Accuracy (Steady State)	$\pm 0.5\%$

#### SUPERSTART ALTERNATOR SPECIFICATIONS

Make (Model)	Marathon Electric (362PSL1650)
Poles – Qty	4
Field Type	Rotating
Insulation Class – Rotor	H
Insulation Class – Stator	H
Total Harmonic Distortion	<3.5%
Telephone Interference Factor	<50

Standard Excitation	Shunt
Bearings	Single Bearing
Coupling	Direct Flexible Disc
Prototype Short Circuit Test	Yes
Voltage Regulator Type	AVR
Quantity of Sensed Phases	1
Regulation Accuracy (Steady State)	$\pm 0.5\%$

# MDG75DF4 | 4.5 L | 75 kVA

## MOBILE DIESEL GENERATOR SET

EPA Emissions Certification: Tier 4 Final



### APPLICATION AND ENGINEERING DATA (CONTINUED)

#### VFLEX ALTERNATOR SPECIFICATIONS

Make (Model)	Marathon Electric (361PSL36113)	Standard Excitation	Shunt
Poles – Qty	4	Bearings	Single Bearing
Field Type	Rotating	Coupling	Direct Flexible Disc
Insulation Class – Rotor	H	Prototype Short Circuit Test	Yes
Insulation Class – Stator	H	Voltage Regulator Type	AVR
Total Harmonic Distortion	<3.5%	Quantity of Sensed Phases	1
Telephone Interference Factor	<50	Regulation Accuracy (Steady State)	±0.5%

#### OPERATING DATA

##### POWER RATINGS

	Standard Alternator		SUPERSTART Alternator		VFLEX Alternator	
	Standby: kW/kVA (A)	Prime: kW/kVA (A)	Standby: kW/kVA (A)	Prime: kW/kVA (A)	Standby: kW/kVA (A)	Prime: kW/kVA (A)
1-phase, 120/240 VAC @ 1.0 pf-zig zag*	55/55 (229)	55/55 (229)	55/55 (229)	55/55 (229)	29/29 (121)	29/29 (121)
3-phase, 208/120 VAC @ 0.8 pf-low wye	68/85 (236)	60/75 (208)	68/85 (236)	60/75 (208)	60/75 (208)	52/65 (180)
3-phase, 240/120 VAC @ 0.8 pf-delta**	68/85 (204)	60/75 (180)	68/85 (204)	60/75 (180)	60/75 (180)	52/65 (156)
3-phase, 480/277 VAC @ 0.8 pf-high wye	68/85 (102)	60/75 (90)	68/85 (102)	60/75 (90)	68/85 (102)	60/75 (97)
3-phase, 600/346 VAC @ 0.8 pf-high wye	N/A	N/A	N/A	N/A	68/85 (81)	60/75 (75)

\*Alternator limited.

\*\*Power ratings achieved through use of optional 4-position voltage selection switch.

##### FUEL AND DEF CONSUMPTION RATES

Prime Load	Fuel: gph (L/hr)	DEF: gph (L/hr)
25%	1.7 (6.4)	0.05 (0.19)
50%	2.6 (9.8)	0.10 (0.38)
75%	3.7 (14.0)	0.16 (0.61)
100%	4.9 (18.5)	0.21 (0.79)
110% (Standby)	5.1 (19.3)	0.22 (0.83)

Deration – Operational characteristics consider maximum ambient conditions. Derate factors may apply under atypical site conditions.

Please contact a Generac Mobile Authorized Service Dealer for additional details. All performance ratings in accordance with ISO3046, BS5514, ISO8528, ISO8665, SAE J1228, SAE J1995, and DIN6271 standards.

# MDG75DF4 | 4.5 L | 75 kVA

## MOBILE DIESEL GENERATOR SET

EPA Emissions Certification: Tier 4 Final



### DIMENSIONS AND WEIGHTS\*

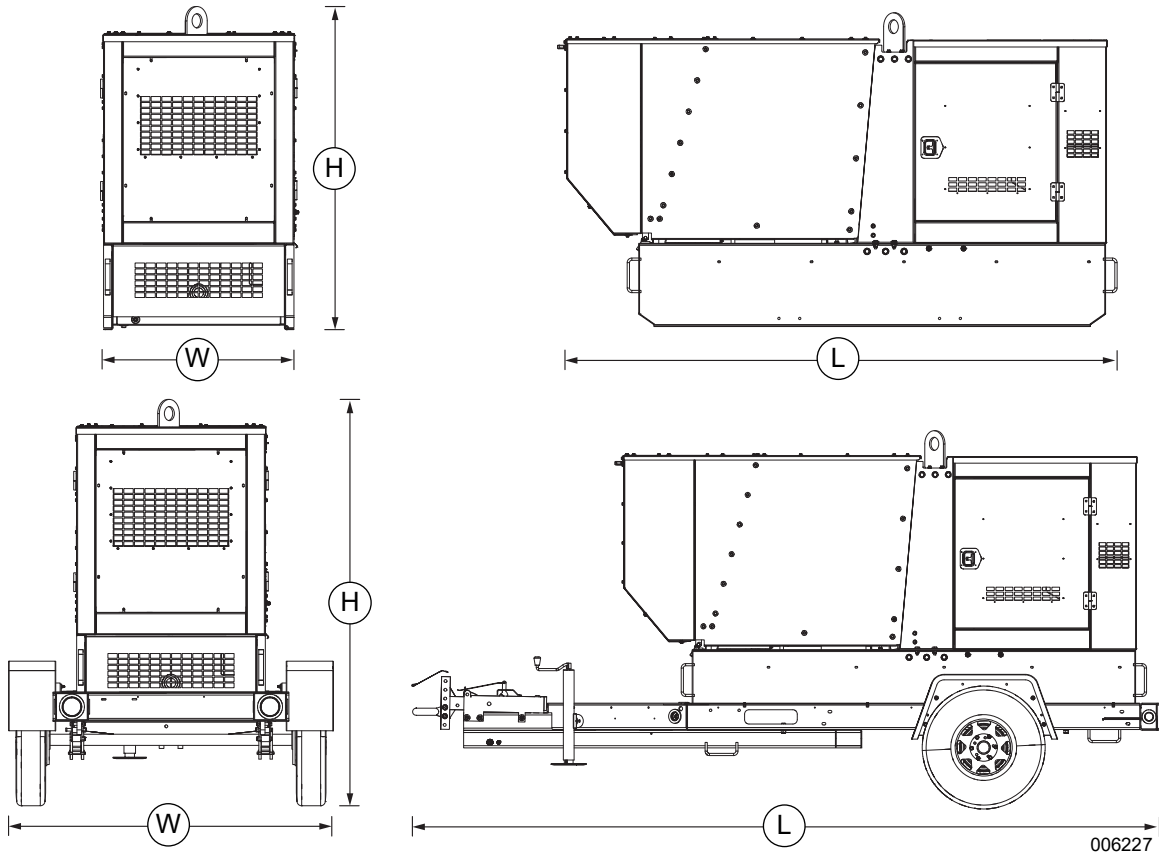

	Runtime: hr*	Usable Fuel Capacity: gal (L)	Dimensions – L×W×H: in (m)	Weight: lb (kg)
Skid	39	146 (552)	119 (3.02)×40 (1.02)×62 (1.57)	Dry: 3,830 (1,740) Operating: 4,790 (2,170)
Trailer	39	146 (552)	170 (4.31)×69 (1.75)×80 (2.03)	Dry: 4,530 (2055) Operating: 5,490 (2,490)

\* Runtime based on 75% prime rated power.

### SOUND RATING

- 74 dB(A) @ 23 ft (7 m) @ 100% prime rated power

\* All measurements are approximate and for estimation purposes only.

**YOUR FACTORY RECOGNIZED GENERAC MOBILE DEALER**

Specification characteristics may change without notice. Dimensions and weights are for preliminary purposes only. Please consult a Generac Mobile Authorized Service Dealer for detailed installation drawings.