

Prepared For:

NC SHERIFFS ASSOC.
 CONTRACT SALES NCSA
 323 W Jones St.
 Raleigh, NC 27603-1365
 (919)743 - 7433
 Reference ID: HV507

Presented By:

WHITE'S INTERNATIONAL TRUCK
 Rick Beavan
 7045 ALBERT PICK RD,
 PO BOX 18605
 GREENSBORO NC 27419 -
 (336)553-4712

NC SHERIFF'S ASSOC. BID 24-08-0421. STANDARD SPECIFICATIONS FOR THE MODEL ARE SHOWN BELOW. OPTIONAL EQUIPMENT IS AVAILABLE TO CUSTOMIZE VEHICLE TO MEET USER SPECIFICATIONS. ALL OPTIONS ARE DISCOUNTED AT THE PUBLISHED RATE.

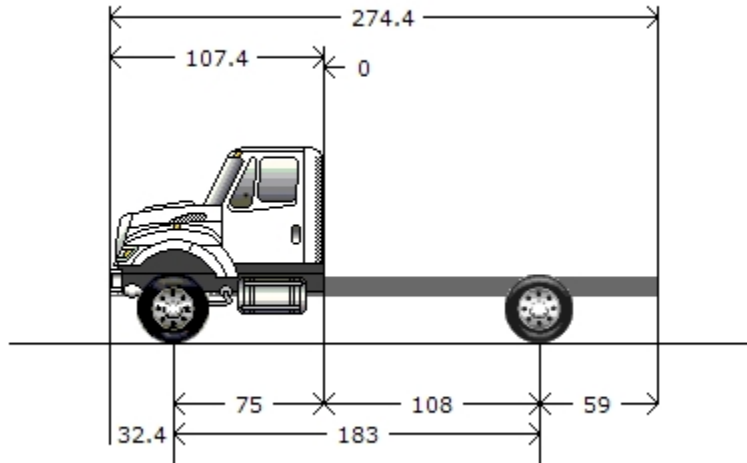

Model Profile
2025 HV507 SFA (HV507)

AXLE CONFIG:	4X2
MISSION:	Requested GVWR: 35000. Calc. GVWR: 35000. Calc. GCWR: 50000 Calc. Start / Grade Ability: 24.46% / 1.84% @ 55 MPH Calc. Geared Speed: 88.3 MPH
DIMENSION:	Wheelbase: 183.00, CA: 108.00, Axle to Frame: 59.00
ENGINE, DIESEL:	{Cummins B6.7 250} EPA 2021, 250HP @ 2400 RPM, 660 lb-ft Torque @ 1600 RPM, 2600 RPM Governed Speed, 250 Peak HP (Max)
TRANSMISSION, AUTOMATIC:	{Allison 3500 RDS} 6th Generation Controls, Wide Ratio, 5-Speed with Overdrive, with PTO Provision, Less Retarder, Includes Oil Level Sensor, with 80,000-lb GVW and GCW Max, On/Off Highway
CLUTCH:	Omit Item (Clutch & Control)
AXLE, FRONT NON-DRIVING:	{Meritor MFS-12-143A} Wide Track, I-Beam Type, 12,000-lb Capacity
AXLE, REAR, SINGLE:	{Dana Spicer S23-172} Single Reduction, 23,000-lb Capacity, R Wheel Ends Gear Ratio: 4.78
CAB:	Conventional, Day Cab
TIRE, FRONT:	(2) 11R22.5 Load Range G ECOPLUS HS3+ (CONTINENTAL), 495 rev/mile, 75 MPH, All-Position
TIRE, REAR:	(4) 11R22.5 Load Range G HDL2 (CONTINENTAL), 493 rev/mile, 75 MPH, Drive
SUSPENSION, REAR, SINGLE:	23,500-lb Capacity, Vari-Rate Springs, with 4500-lb Capacity Auxiliary Rubber Springs
PAINT:	Cab schematic 100WK Location 1: 9219, Winter White (Std) Chassis schematic N/A