

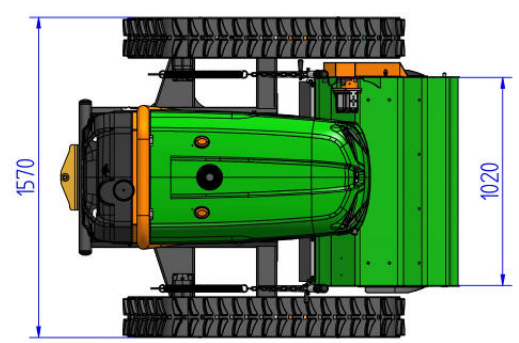

Green Climber^{NA}

The Green Climber F300 PRO Remote- Controlled Slope Mower

- YANMAR DIESEL, TIER IV FINAL ENGINES
- EPA & CA EMISSION COMPLIANT
- 60 DEGREE SLOPE CAPACITY, **ALL DIRECTIONS**
- 500 FT RADIO REMOTE RANGE
- 0-2 INCH CUTTING CAPACITY
- ON-BOARD BATTERY CHARGER
- CLEAN-FIX AUTO REVERSING FAN
- ADJUSTABLE CUTTING HEIGHTS 0-6 INCHES
- LOW CENTER OF GRAVITY FOR ADVANCED STABILITY
- EASY TRANSPORT
- LOW OPERATING COSTS!

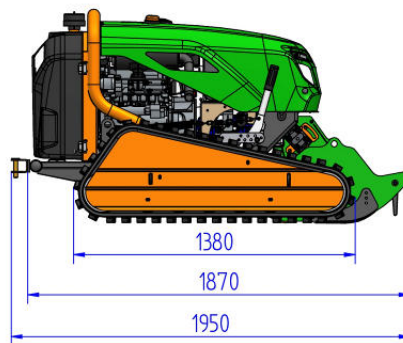
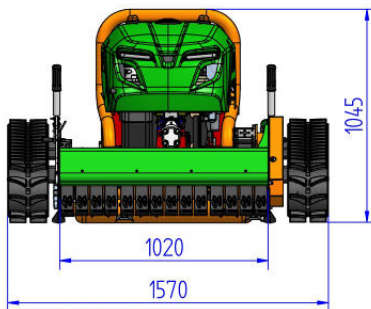

Green Climber F300 PRO is a long range remote controlled flail mower. The remote technology of the F300 keeps the operator at a safe distance while conquering high risk jobs.

Green Climber F300 is equipped with a high performance flails for roadside maintenance. The Yanmar diesel engines are equipped with a special patent system that warrants engine lubrication even when working on high gradient slopes of the workday of the machine.





Green Climber^{NA}

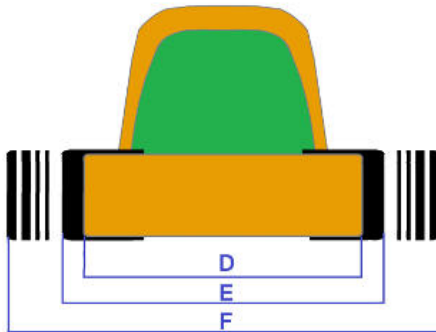
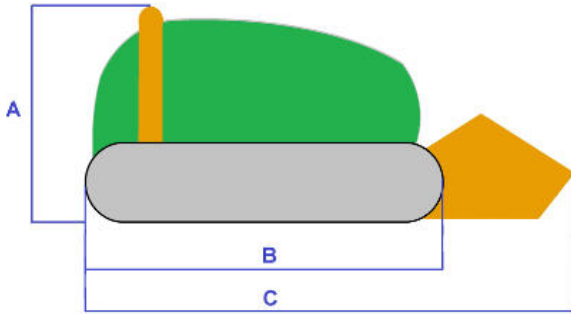

MODEL	F300 PRO
A - max. height	41"
B - length without accessory	74"
C - length with accessory	77"
D - Flail width	44"
E - minimum machine width	62"
F - maximum machine width	62"
Dry weight	1642 lbs
Max working gradients	60°
Speed	5 mph
Engine Diesel	YANMAR 3TNV80
Cylinders	3
EPA - TIER 4	Yes
Engine power	25 Hp
Engine torque	69 Nm
Cooling system	Liquid
Fuel tank	4 Gal
Hydraulic oil tank	3.2
Flail weight	242 lbs
Flail speed	3000 rpm

GREEN CLIMBER F300 PRO STRONG POINTS:

Climbing Capability

The wider undercarriage & tracks make Green Climber F300 PRO unstoppable on any slope. In extreme situations the undercarriage width of 62" and the low center of gravity is perfect to allow stability and balance. Green Climber F300 PRO has the lowest center of balance among slope mowers in its class.

Perfect traction on extreme slopes
Thanks to its low weight and low center of gravity, it can work on unbelievable steep slopes up to 60°. The flail placed in between the tracks allows extreme versatility and stability in areas of uneven ground or extreme slopes!

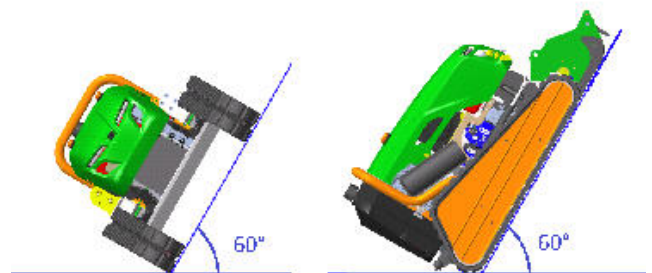



Green Climber^{NA}

The Remote control

The iMET M880 remote control system can reach a distance of up to 500 ft. The radio remote controls engine start/stop, acceleration, and attachment start/stop. Furthermore, it has a self-correcting steering system that, in the case of a very steep slope it can be used to correct the direction.

There is an on-board battery charger with extra battery always on the machine.

Diesel Engines :EPA and TIER 4 final

The F300 is equipped with a Yanmar engine, compliant with EPA & California regulations. Thanks to a bigger oil sump engine lubrication is assured on any slopes. The engine, the radiator and the pumps are fixed to the main frame with high quality silent blocks.

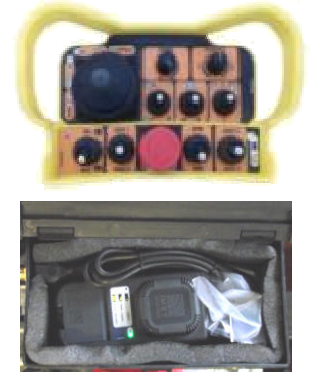

Mower Deck:

The F300 PRO offers flail style cutting. The high performance steel flails come in standard bent knife flails or t-style flails. The heavy duty style allows the F300 to cut through heavy, stubborn grass and brush.

The mower deck is located in between the tracks instead of in front.

This gives the machine a higher climbing capacity and prevents the cutting area from getting stuck in ditches or steep crevices.



~~Double~~ Double-step air filtering system to assure good "engine breathing" with a "spinning" pre-filter system. It has a rotating device that prevents debris from entering the main air filter; it improves the engine performance and reduces fuel consumption.



Hydraulic system:

The hydraulic system is fully proportional allowing the operator to have smooth movements and to control the machine drive and attachments perfectly. The tracks traction motors have electronic variable speed (EVS) rather than 2 speed. The EVS always gives the maximum torque and power at any speed.

Undercarriage:

The F300 PRO has a special design patent for its undercarriage to avoid any de-tracking risk in extreme steep conditions and to assure the highest traction on slopes.





Green Climber^{NA}

Automatic cleaning system "CLEANFIX"

The Clean-Fix system reverses the air flow automatically and cleans all debris from the machine rear. If needed, the cleaning of the radiator can be manually actuated also with a button on the side of the remote control. When the radiator is kept clean there is lower fuel consumption and lower engine temperature.

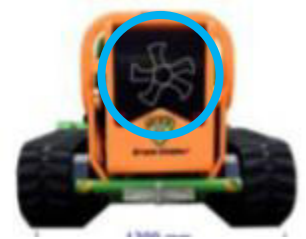

The Green Climber Advantage:

- Protective hood that covers and protects the engine, computer, remote receiver, air filter, etc;
- Headlights to work even when it is dark
- Roll bar
- Towing hook
- Electronic control panel + beepers + warning lights which give information about the state of the machine: low fuel level, oil pressure, overheating, etc.
- On-Board battery & battery charger for the iMET remote

- Only requires a single operator to perform the work of 10 people!
- Can be easily transported on a trailer or small van
- Can reach areas with very steep slopes (up to 60°) in any direction
- 10 times faster in performance compared to traditional systems
- Maximum safety: the remote control and the special protection of the mower deck prevent objects being thrown towards the operator
- Agility to avoid obstacles such as trees, road signs or other objects
- Low operative costs compared to traditional systems
- Maximum safety for operators
- Can access more extreme areas that tractors or boom mowers can not
- Reduces risk and liability on the job
- Allowing technology to work in your favor!