



WHEEL LOADER | 427/437

427 – Gross engine power: 179 hp (133 kW) Operating weight: 28880 - 36376 lbs (13.1-16.5 t)
Full turn tipping load: 18966 lbs (8603 kg) Standard bucket capacity 3.1 yd³ (2.3 m³)

437 – Gross engine power: 183 hp (136 kW) Operating weight: 33272 - 39242 lbs (15.1-17.8 t)
Full turn tipping load: 21215 lbs (9623 kg) Standard bucket capacity 3.5 yd³ (2.7 m³)



A QUALITY PROCESS.

WE KNOW THAT A WHEEL LOADER IS A KEY PART OF THE ON-SITE PROCESS. THAT'S WHY THE JCB 427 AND 437 ARE BUILT ON A FOUNDATION OF QUALITY AND RELIABILITY. THE PROCESSES WE'VE USED THROUGH DESIGN AND MANUFACTURE WILL SAFEGUARD YOUR WORKING PROCESS, HOUR AFTER HOUR, DAY AFTER DAY.

Designed to work hard.

1 Finite element analysis, as well as extensive endurance and rig testing ensure superior structural strength and durability. Cold cell testing guarantees the standard starting performance at -4°F (20°C).

2 The new front chassis is more durable than ever; it's been strengthened with additional ribs and gussets for maximum service life.

Precision machining provides high tolerances and accurate location of pins and bushings.

3 The JCB 427 and 437 can be specified for heavy-duty applications like waste or corrosive material handling.



Protecting ancillaries.

4 A solid cast rear counterweight protects the rear of the machine – including the rear lights and cooling pack – from damage. You can choose for additional guards on the front screen, lights, underbelly and rear grill. For additional protection, there are impact-resistant fender edges and trims fitted.

Well articulated.

5 Hoses are neatly routed and clamped through the articulation joint, well away from any pinch points.

6 Designed to tolerate both vertical and horizontal loadings, the articulation joint has a heavy-duty center pin and oversized bushing, as well as twin taper roller bearings on the top box joints.

These machines have integral steel fluid tanks for the ultimate in leak protection; a far superior solution to the plastic tanks favored by some competitors.

The articulation joint on the JCB 427 and 437 has a heavy-duty box section that's much stronger than a single plate with a boss. Steering rams are positioned high up and well protected from possible impact and site damage.

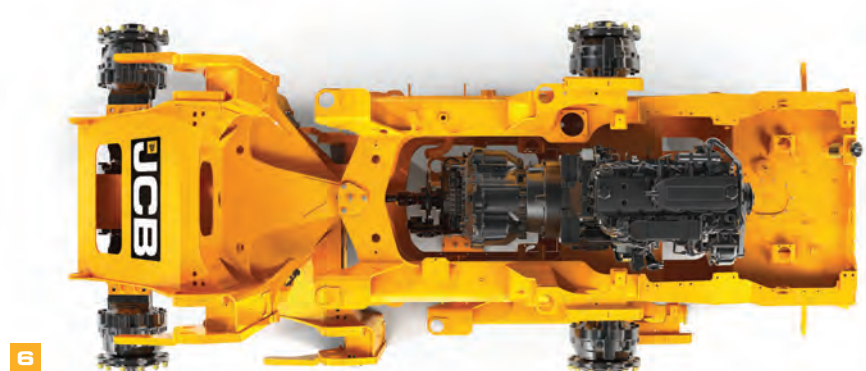

PRODUCTIVE PERFORMANCE.

THE 427 AND 437 CAN PERFORM GREAT FEATS OF PRODUCTIVITY. WITH HIGH POWER AND TORQUE, BOTH MACHINES MEET TIER 4 FINAL/STAGE IV EMISSIONS LEGISLATION WITHOUT NEEDING A DPF WHICH ELIMINATES THE NEED FOR PERIODIC REGENERATION.

Drivetrain performance.

1 The Cummins QSB 408in³ (6.7 liter) engine achieves maximum engine power (179hp/133kW in the 427, 183hp/136kW in the 437) and peak torque (620lbs-ft/841Nm) at low revs for excellent response.

A variable geometry turbocharger provides increased performance at low engine speed for improved cycle times and tractive effort.

Loading productivity.

2 JCB's optional quickhitch makes attachment changing quick and efficient. The quickhitch is designed to be compatible with aftermarket attachments too.

3 Powerful twin variable displacement piston pump hydraulics can circulate a massive 66.5gal/min (252l/min) for fast cycles and excellent multi-function capability.

COMMANDPLUS controls.

A choice of 3 or 4-spool hydraulics gives you the scope for invaluable extra versatility. Flow can be adjusted from the cab via the all-new Command Plus controls.

There's no need to worry about wasting time and money replacing a diesel particulate filter (DPF) on your loader; its Cummins engine meets Tier 4 Final/Stage IV legislation using only exhaust gas recirculation (EGR), selective catalytic reduction (SCR) and diesel oxidation catalyst (DOC). This setup also improves fuel economy.





Z bar (ZX)

HT Standard Lift

HT High Lift

HT Super High Lift

4

Loading productivity (continued).

4 You can choose your ideal loader arm on a 427 and 437, with Z-bar linkage (ZX) for high breakout applications or high torque (HT) for parallel lift and multi-attachment use.

Choose a HT high lift on the 427 or 437, or HT super high lift on the 437 and you can use the machine for higher loading height applications.

- > Standard differentials are ideal for hard standing ground conditions.
- > Limited slip differentials is perfect for soft, muddy terrain with reduced traction.
- > Standard rear differential with an automatic locking front axle differential provide excellent traction in varied ground conditions.

Drivetrain productivity.

5 The 427 and 437's optional 5-speed transmission with torque convertor lock-up provides closer ratios for better acceleration, hill climbing and travel performance. The lock-up element eliminates losses from the torque converter for faster cycle times and improved efficiency.

6 With a range of axle options, you can tailor performance to any application.

6



5

The innovative electronic management performs progressive clutch cut-off for efficient, productive loader control. This feature controls tractive effort via the transmission, diverting maximum power to the loader hydraulics and reducing service brake wear and fuel consumption.

EFFICIENT BY DESIGN.

THE JCB 427 AND 437 ARE DESIGNED TO MOVE MORE MATERIAL FOR LESS. TO ACHIEVE THIS, WE'VE DESIGNED THE ENGINE, AXLES, DRIVELINE AND HYDRAULICS TO WORK IN HARMONY WITH EACH OTHER, FOR ULTIMATE EFFICIENCY AND DURABILITY.



Automatic idle returns the engine to 700rpm after 30 seconds of inactivity.

An efficient engine.

1 A hydraulic cooling fan automatically reacts to ambient temperature and adjusts the fan speed to optimize energy and reduce fuel consumption. An additional benefit of this setup is reduced noise levels.

2 Eco Mode caps engine speed at 1800rpm for reduced fuel consumption. Productivity nonetheless remains formidable.

3 Our torque lock-up 5 speed transmission gives you up to 100% efficiency in gears 2 to 5 for improved fuel consumption. Closer gear ratios provide lower engine speed in each gear.



1



2



An efficient engine (continued).

- 4** Wheel speed braking means the brakes rotate at the same speed as the wheels for heat and drag reduction, as well as improved fuel economy and access for maintenance and repairs.
- 5** Unloaded spool valves in the valve block mean that arms lower under gravitational, not hydraulic force, reducing fuel consumption.
- 6** JCB's innovative variable displacement pumps feed a load-sensing valve block which only consumes power on demand, providing precise, efficient loader control.
- 7** No DPF means potentially periodic dangerous temperatures involved in regeneration and downtime caused through DPF maintenance or failures are eliminated. The fuel that would have been needed to restore your DPF can be used instead for production work.



COMMANDPLUS controls.
 JCB Smoothride load suspension limits shock loadings and therefore reduces material spillage and structural stress, as well as increasing operator comfort. The speed of engagement is adjustable from within the cab using the latest state-of-the-art CommandPlus controls.



Adjustable SRS engagement speed.



Adjustable Auxiliary control.

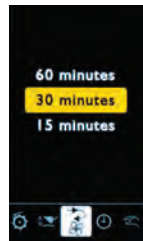

Adjustable reversing fan intervals.



COMMANDPLUS.

THE LATEST JCB 427 AND 437 WHEEL LOADERS BOAST OUR ALL-NEW COMMAND PLUS CAB. THIS UNIQUE APPROACH TO ERGONOMICS IS THE RESULT OF A RADICAL RETHINK AND AN EXTENSIVE RESEARCH PROGRAM. EXPECT BEST-IN-CLASS COMFORT, VISIBILITY, ERGONOMICS AND QUIETNESS.

See the difference.

1 You'll immediately notice the totally redesigned ROPS structure; this has allowed the A pillars to be moved to the same width as the rear of the cab, providing a larger interior with a superb panoramic front windscreen. All switches and auxiliary controls are now located on the right-hand A-pillar for easier access.



2 Using your machine's simple, dedicated menu interface is easily done with an intuitive optional rotary controller.

3 Operating your 427 or 437 loader is now easier than ever. All of the controls are seat-mounted, even going as far as to move with the seat suspension. You can also select the control system that's best for your operators: choose from single lever joystick or multi-lever configurations, all using electro-hydraulics for the ultimate in precision.



4 There are two full color LCD screens to navigate the operating menus, one of which doubles as a monitor for the optional rear-view camera and CommandPlus control menu.



The noise level in the cab is an incredibly low 68dB(a): so quiet you can hardly hear the engine running.

5 To keep the operator environment comfortable for working at all times, we've positively pressurized the cab to eliminate dust and fumes.

6 After extensive research into operator ergonomics, we've devised the Command Driving Position, which boasts the optimal control layout for a multitude of different driver shapes and sizes, ranging from an air suspension standard seat to a super deluxe half leather seat, featuring fully adjustable heating and cooling functionality, electrically adjustable lumbar support and adjustable dampers.

7 A set and forget feature makes operator access even easier. In short, your preferred steering wheel position is stored and can be instantly returned to, even after you've folded the wheel away.

Specify your 427 or 437 with either air conditioning or automatic climate control to create perfect working temperatures.

With a dedicated media port on board, you can be assured of superb connectivity for all your electronic devices.

A sliding window on both sides of the cab allows easy communication with people outside the machine.

The electronic parking brake offers numerous advantages: it's quick and easy to operate, and, because there's no cable, there are fewer holes in the cab. This helps to isolate the operator environment further.

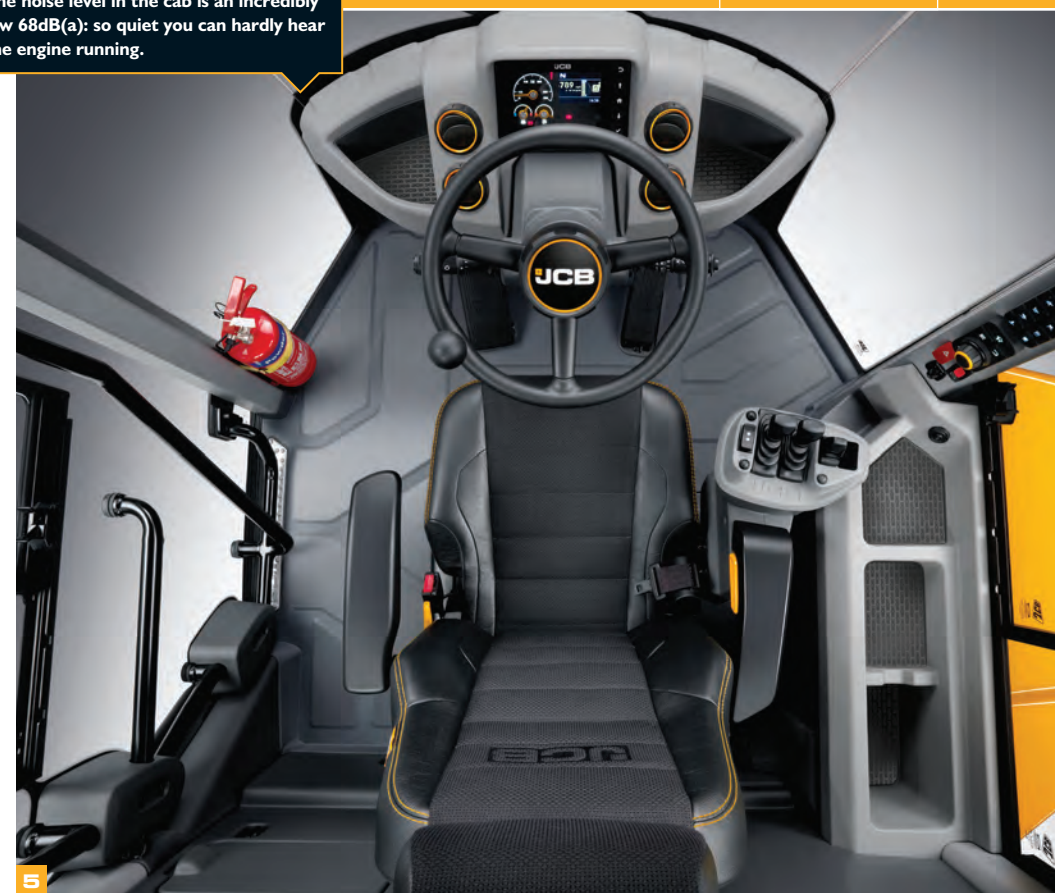

LOW MAINTENANCE LONG INTERVALS.

WHEEL LOADERS NEED TO SPEND THE MAXIMUM AMOUNT OF TIME HARD AT WORK. WE'VE DESIGNED THE 427 AND 437 TO DO JUST THAT, WITH LONG SERVICE INTERVALS AND QUALITY COMPONENTS.

Routine maintenance.

- 1 It's easy to get to the engine on a new JCB 427 and 437 with a large automatic opening single-piece engine hood.
- 2 Accessing the diesel and DEF (Diesel Exhaust Fluid) tanks is similarly straightforward via the lockable grill at the rear of the machine.

You can check washer fluid level, engine oil and coolant from inside the cab, with all other routine checks and grease points located at ground level. This makes life both easier and safer.

- 3 Most Tier 4 Final/Stage IV engines use a costly Diesel Particulate Filter (DPF) that can cost a lot of money and time when it needs replacing. The Cummins engine is DPF-free, reducing your servicing and running costs.

- 4 A large single-faced wide-core cooling pack package provides quick, easy and safe cleaning.
- 5 With the optional auto lubrication kit, your machine will take care of its own greasing requirements.



Less servicing, more uptime.

5 The CommandPlus cab relays machine condition giving real time alerts, safeguarding both the machine and the operator.

The intuitive CommandPlus help function provides the operator with meaningful descriptions of in-cab switch function. Using the "?" button, this allows new or unfamiliar operators to quickly and easily understand machine functions without having to refer to the operators manual.

6 By using premium components in the 427 and 437 (Cummins engine, ZF transmissions and axles, Rexroth pumps and Parker valve blocks), we've built in long service life as standard.

7 Full hydraulic dual circuit braking with multiple oil immersed discs gives the braking system a virtually maintenance-free lifespan.

A cyclonic engine fan scavenge filter provides four times the filtering capacity of a standard air filter. It's a longer life system, with fewer components and a higher level of efficiency, making for better engine protection. There's a large 76.6 US Gallon (290 Liter) fuel tank fitted, which ensures maximum working hours between refills.

Heating and ventilation filters are conveniently located behind an external access panel.

The main fuse board and relays have been repositioned next to the door for easy access.

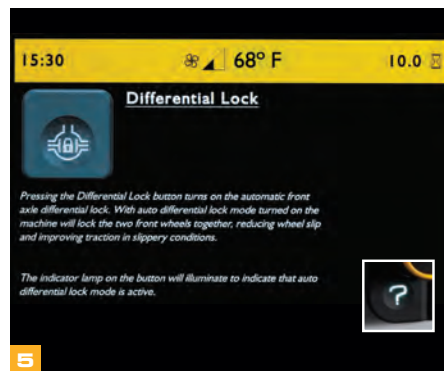
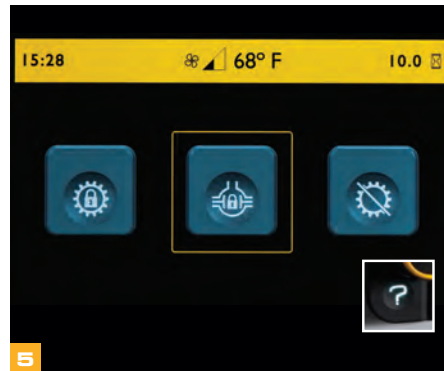

COMMANDPLUS controls.
If you're planning to use your wheel loader in environments with large amounts of airborne debris, opt for the adjustable reversing fan. The fan can be operated via the CommandPlus controls, and even swings out for easy cleaning access.

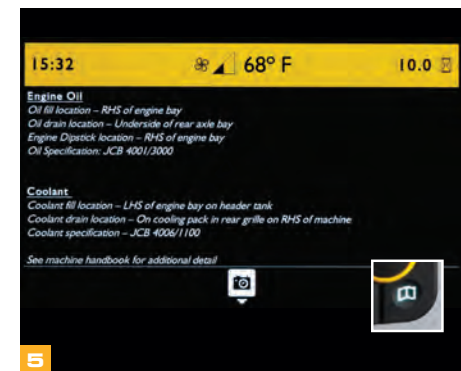
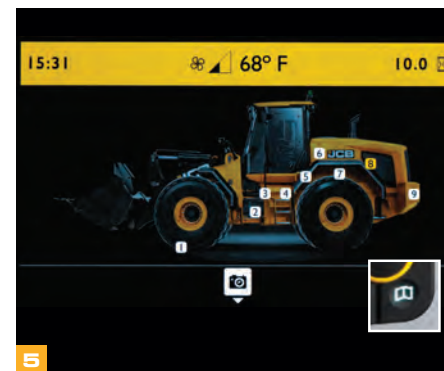

DRIVE SAFELY.

THE NEW JCB 427 AND 437 ARE DESIGNED TO KEEP THE OPERATOR AND YOUR WORKSITE SAFE AT ALL TIMES. GREAT VISIBILITY, NON-SLIP SURFACES AND FULL ROPS/FOPS PROTECTION ARE JUST THE START.

Safely does it.

- 1 Our optional rear-view camera displays an unobstructed rear view on the in-cab color monitor onboard your 427 and 437.
- 2 Superb visibility in dark conditions is guaranteed with JCB's optional LED lighting.
- 3 You'll find the rear-view mirrors mounted in front of the A-pillars for improved all-around visibility.
- 4 Visibility over the rear engine hood is excellent because the air cleaner is underneath the engine hood and the exhaust stack is located centrally.



Safely does it (continued).

5 Access steps on the 427 and 437 are inclined and equally spaced, complemented by well positioned grab handles for three points of contact at all times.

6 Full fender coverage flaps have been carefully designed to keep forward spray to a minimum for all tire options. This increases safety and decreases debris build-up.

7 Door hinges are now mounted on the A-pillar; this simple change has created much better access via a larger and wider door opening. It also means you can access the rear of your loader more safely.

The battery and tool box are lockable for added security.

8 The cab is isolator-mounted, compliant with ROPS/FOPS standards, and positively pressurized against dust. You can choose from fresh air or carbon filters as well.

9 Engines fitted with a DPF can pose an increased fire risk because extreme heat can be created in regeneration mode. The new 427 and 437 don't use DPFs, so this is no cause for concern.

Non-slip walkways and additional grab handle options allow for safe movement around the machine.



LIVELINK, WORK SMARTER.

LIVELINK IS AN INNOVATIVE SOFTWARE SYSTEM THAT LETS YOU MANAGE JCB MACHINES REMOTELY – ONLINE, BY EMAIL OR BY MOBILE PHONE. ACCESS EVERYTHING FROM MACHINE ALERTS TO FUEL REPORTS AND HISTORY INFORMATION, WITH ALL DATA STORED AT A SECURE CENTER.

Productivity and cost benefits

By providing information like idle time monitoring and machine fuel consumption, JCB Livelink helps reduce your fuel usage, saving money and improving productivity. Machine location information can help improve efficiency and perhaps even reduce insurance costs.

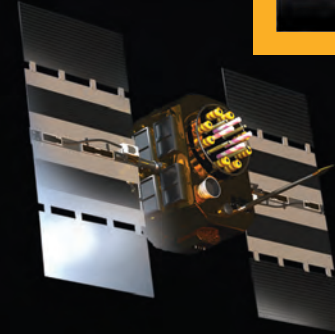

Maintenance benefits

Manage machine maintenance easily – accurate hours monitoring and service alerts improve maintenance planning, while real-time location data helps you manage your fleet. Critical machine alerts and maintenance history records are also available.



Security benefits

Livelink's real-time geofencing alerts tell you when machines move out of predetermined zones, and real-time curfew alerts inform you of unauthorized usage. Further benefits include real-time location information.



A GREAT BUSINESS DECISION.

WE'LL PROVIDE YOU WITH FIRST CLASS SUPPORT AND ASSISTANCE TO SUIT YOUR EXACT BUSINESS NEEDS RIGHT FROM DAY ONE. SO WHEREVER YOU ARE, YOUR MACHINE WILL ALWAYS PERFORM TO ITS FULL POTENTIAL – ONE OF MANY REASONS WHY STARTING A WORKING RELATIONSHIP WITH JCB IS A GREAT BUSINESS DECISION.

Machine selection

Your JCB dealer has the right technical knowledge and expertise to ensure that you access all the machine options available to you. This includes rental options and new or used machine sales.

Rebuild and refurbishment program

If your business isn't in a position to buy a brand new machine, then JCB's rebuild and refurbishment program can help you to extend the service life of your current vehicle cost-effectively.

Technical support

All local JCB dealers have instant access to factory expertise and technical support to provide you with the maximum machine uptime. JCB's Global Parts Centers, meanwhile, deliver around 95% of all parts anywhere in the world within 24 hours.

Component monitoring

JCB machines benefit from a sophisticated component monitoring program that provides preventive maintenance and oil sampling to keep everything working at its optimum level.

Service support

We offer a range of extended warranties, from JCB PremierCover (full comprehensive coverage) to JCB PowertrainCover (engine, axles, transmission and hydraulic pump coverage). Service agreements, as well as service-only or Repair and Maintenance contracts ensure that we have the up-time of your wheel loader totally covered. Our dealer maintenance specialists around the world charge competitive labor rates, and offer non-obligation quotations as well as fast, efficient repair work.

Finance

Finance specialists are always on-hand to provide fast, flexible, competitive quotes. Packages can be tailored to suit your specific business needs.



STATIC DIMENSIONS

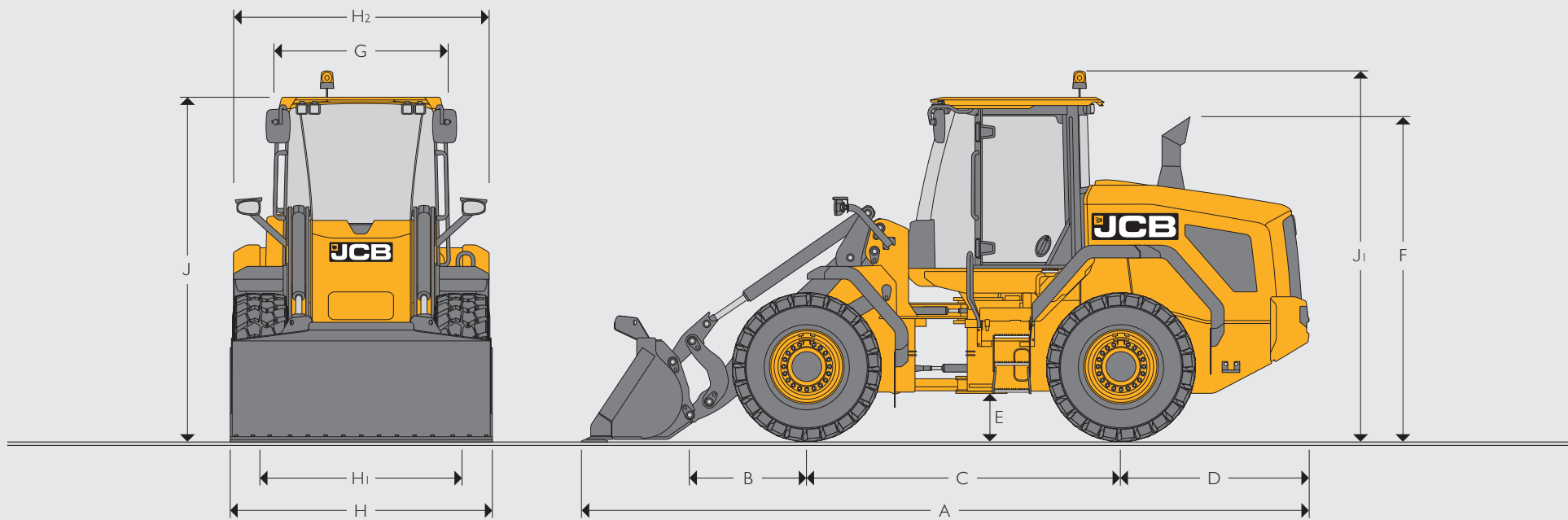

		427 HT	427 HT HL	427ZX	437 HT	437 HT HL	437 HT SHL	437 ZX	
A	Overall length	ft-in (mm)	23-2 (7070)	24-9 (7532)	23-2 (7069)	23-11 (7301)	26-0 (7928)	27-10 (8485)	24-0 (7306)
B	Axle to pivot pin	ft-in (mm)	3-9 (1134)	5-3 (1596)	3-8 (1108)	4-1 (1246)	6-2 (1873)	8-0 (2430)	4-1 (1251)
C	Wheel base	ft-in (mm)	10-0 (3050)	10-0 (3050)	10-0 (3050)	10-0 (3050)	10-0 (3050)	10-0 (3050)	10-0 (3050)
D	Axle to counterweight face	ft-in (mm)	6-0 (1833)	6-0 (1833)	6-0 (1833)	6-0 (1833)	6-0 (1833)	6-0 (1833)	6-0 (1833)
E	Minimum ground clearance	ft-in (mm)	1-7 (472)	1-7 (472)	1-7 (472)	1-7 (472)	1-7 (472)	1-7 (472)	1-7 (472)
F	Height over exhaust	ft-in (mm)	10-3 (3133)	10-3 (3133)	10-3 (3133)	10-3 (3133)	10-3 (3133)	10-3 (3133)	10-3 (3133)
G	Width over cab roof	ft-in (mm)	5-3 (1594)	5-3 (1594)	5-3 (1594)	5-3 (1594)	5-3 (1594)	5-3 (1594)	5-3 (1594)
H	Maximum width over tires	ft-in (mm)	8-2 (2483)	8-2 (2483)	8-2 (2483)	8-6 (2598)	8-6 (2598)	8-6 (2598)	8-6 (2598)
H1	Wheel track	ft-in (mm)	6-5 (1955)	6-5 (1955)	6-5 (1953)	6-9 (2054)	6-9 (2054)	6-9 (2054)	6-9 (2054)
H2	Maximum width over fenders	ft-in (mm)	8-2 (2484)	8-2 (2484)	8-2 (2477)	8-5 (2560)	8-5 (2560)	8-5 (2560)	8-5 (2556)
J	Height over cab roof and lowered beacon	ft-in (mm)	11-0 (3360)	11-0 (3360)	11-0 (3360)	11-0 (3360)	11-0 (3360)	11-0 (3360)	11-0 (3360)
J1	Height over raised beacon	ft-in (mm)	12-3 (3720)	12-3 (3720)	12-2 (3720)	12-2 (3720)	12-2 (3720)	12-2 (3720)	12-2 (3720)
	Front axle weight	lb (kg)	12685 (5754)	13184 (5980)	13847 (6281)	13975 (6339)	15047 (6825)	17946 (8140)	16021 (7267)
	Rear axle weight	lb (kg)	16815 (7627)	16779 (7611)	16255 (7373)	19297 (8753)	19149 (8686)	17242 (7821)	18065 (8194)
	Total weight	lb (kg)	29500 (13381)	29963 (13591)	30102 (13654)	33272 (15092)	34196 (15511)	35188 (15961)	34086 (15461)
	Height over engine cover from ground fully open	ft-in (mm)	11-0 (3611)	11-0 (3611)	11-0 (3611)	11-0 (3611)	11-0 (3611)	11-0 (3611)	11-0 (3611)
	Increase in vehicle length with engine hood open (rear grill shut)	ft-in (mm)	+3-1 (+928)	+3-1 (+928)	+3-1 (+928)	+3-1 (+928)	+3-1 (+928)	+3-1 (+928)	+3-1 (+928)

427 based on a machine equipped with Michelin 20.5R25 XHA2 (L3) radial tires & direct mount 2.5 yd³ (1.9m³) bucket and toe plates.

437 based on a machine equipped with Michelin 20.5R25 XHA2 (L3) radial tires & direct mount 3.0 yd³ (2.3m³) bucket and toe plates.

STATIC DIMENSIONS

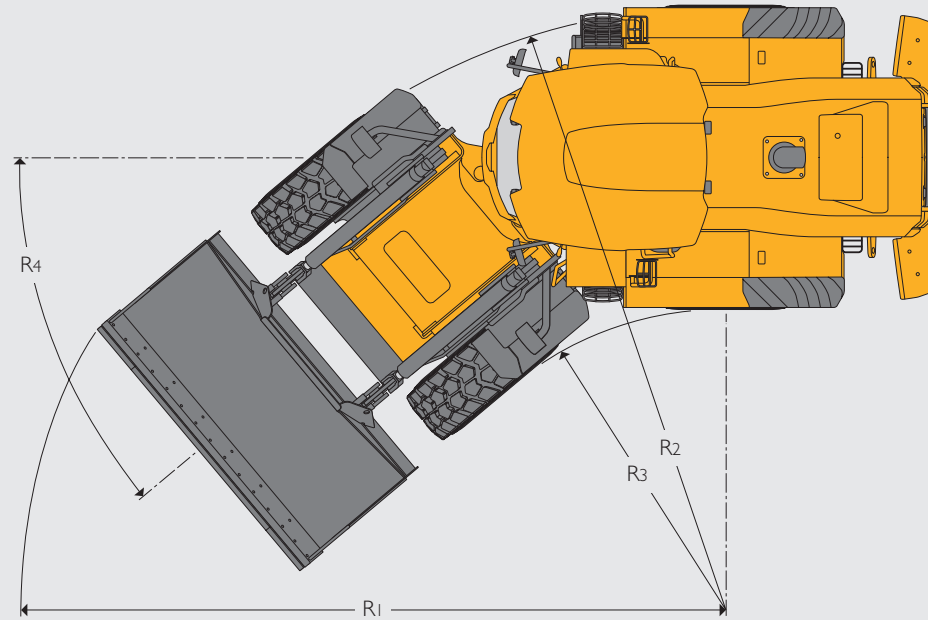

			427HT	427 HT HL	427ZX	437 HT	437 HT HL	437 HT SHL	437 ZX
R1	Maximum turn radius over bucket	ft-in (mm)	19-4 (5902)	19-10 (6035)	19-6 (5933)	19-9 (6021)	20-7 (6286)	21-9 (6626)	19-10 (6041)
R2	Maximum turn radius over tire	ft-in (mm)	18-0 (5483)	18-0 (5483)	18-0 (5483)	18-0 (5483)	18-0 (5483)	18-0 (5483)	18-0 (5483)
R3	Inside turn radius	ft-in (mm)	9-6 (2896)	9-6 (2896)	9-6 (2896)	9-6 (2896)	9-6 (2896)	9-6 (2896)	9-6 (2896)
R4	Articulation angle	degrees	40	40	40	40	40	40	40

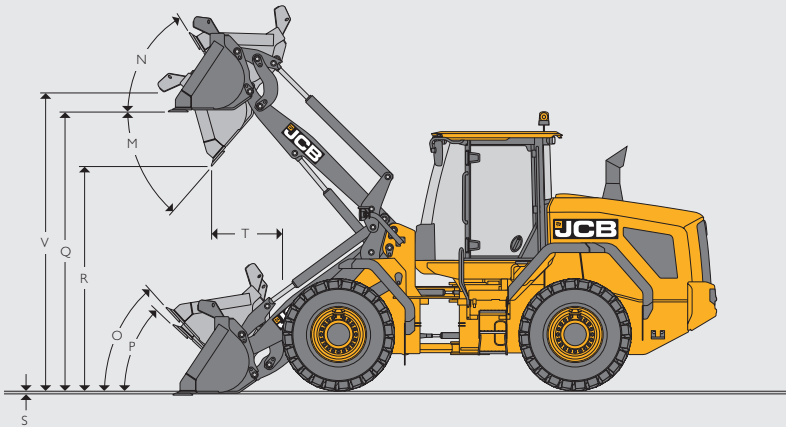

TIRE SIZE 427 HT

Tire size	Manufacturer	Type	Rating	Operating weight lbs (kg)	HT		Dimensions	
					STL lbs (kg)	FTTL lbs (kg)	Vertical in (mm)	Width in (mm)
20.5R25	Michelin	XHA2	L3	0 (0)	0 (0)	0 (0)	0.0 (0)	0.0 (0)
20.5R25	Michelin	XTLA	L2	-247 (-112)	-174 (-79)	-150 (-68)	-0.3 (-7)	0.2 (4)
20.5R25	Michelin	XLDD2A	L5	1155 (524)	814 (369)	703 (319)	1.2 (30)	0.2 (6)
20.5R25	Michelin	XMINED2	L5	1561 (708)	1098 (498)	950 (431)	2.3 (58)	1.3 (34)
550/65R25	Michelin	XLDD2A	L3	-168 (-76)	-119 (-54)	-101 (-46)	-1.7 (-44)	0.8 (21)
20.5R25	Michelin	XSNOPPLUS	L2	-168 (-76)	-119 (-54)	-101 (-46)	-0.4 (-11)	0.2 (6)
620/75R26	Michelin	MEGAXBIB	N/A	-696 (-315.6)	-489 (-222)	-423 (-192)	2.7 (68)	4.3 (108)
650/65R25	Michelin	XLD	L3	1215 (551.2)	855 (388)	739 (335)	-0.4 (-10)	9.8 (249)
750/65R26	Michelin	MEGAXBIB	N/A	-146 (-66.4)	-104 (-47)	-88 (-40)	3.2 (81)	18.7 (474)
20.5-25	Goodyear	SGL (16 ply)	L2	-520 (-236)	-366 (-166)	-317 (-144)	-0.2 (-5)	0.2 (4)
20.5-25	Goodyear	HRL (16 ply)	L3	-53 (-24)	-37 (-17)	-33 (-15)	1.5 (37)	0.2 (4)
20.5R25	Goodyear	TL-3A+	L3	644 (292)	454 (206)	392 (178)	0.4 (11)	0.2 (4)
20.5R25	Goodyear	RL-5K	L5	1199 (544)	844 (383)	730 (331)	1.9 (49)	0.2 (4)
20.5R25	JCB	Earthmover	L3	203 (92)	143 (65)	123 (56)	1.6 (41)	0.5 (12)
20.5R25	SG Revolution	SE	Solid	4504 (2043.2)	3172 (1439)	2740 (1243)	0.7 (17)	3.7 (95)
20.5R25	SG Revolution	S2 C2 DWL	Solid	4778 (2167.2)	3364 (1526)	2908 (1319)	0.2 (6)	3.7 (95)
20.5-25	JCB	Sitemaster (16ply)	L3	-344 (-156)	-243 (-110)	-209 (-95)	0.8 (21)	-0.3 (-7)
20.5R25	Nokian	GRIP TL	L3	-441 (-200)	-311 (-141)	-269 (-122)	0.2 (4)	-0.3 (-7)

Heavy-duty axles (required with 5 speed and 750 width agricultural tires and high lift arms).

LOADER DIMENSIONS 427 HT

		Direct						Quickhitch					
		General purpose						General purpose					
		Tipped teeth		Reversible toeplate				Tipped teeth		Reversible toeplate			
Bucket mounting													
Bucket type													
Bucket equipment		Tipped teeth		Reversible toeplate				Tipped teeth		Reversible toeplate			
Bucket capacity (SAE heaped 100%)	yd ³ (m ³)	2.35 (1.8)	2.62 (2)	2.49 (1.9)	2.75 (2.1)	3.14 (2.4)	3.53 (2.7)	2.35 (1.8)	2.62 (2)	2.49 (1.9)	2.75 (2.1)	3.14 (2.4)	3.53 (2.7)
Bucket capacity (struck)	yd ³ (m ³)	2.04 (1.556)	2.31 (1.765)	2.11 (1.616)	2.39 (1.83)	2.69 (2.057)	3.07 (2.346)	2.03 (1.554)	2.29 (1.749)	2.08 (1.594)	2.34 (1.787)	2.69 (2.057)	3.07 (2.346)
Bucket width	ft-in (mm)	8-4 (2550)	8-4 (2550)	8-4 (2550)	8-4 (2550)	8-10 (2700)	8-10 (2700)	8-4 (2550)	8-4 (2550)	8-4 (2550)	8-4 (2550)	8-10 (2700)	8-10 (2700)
Bucket weight	lb (kg)	2538 (810)	2698 (850)	2564 (810)	2725 (850)	2478 (1136)	2643 (1211)	2504 (800)	2670 (850)	2538 (800)	2698 (850)	2564 (1136)	2725 (1211)
Maximum material density *	lb/yd ³ (kg/m ³)	4438 (2633)	3954 (2346)	4204 (2494)	3766 (2234)	3204 (1901)	2810 (1667)	4109 (2438)	3661 (2172)	3894 (2310)	3487 (2069)	2968 (1761)	2602 (1544)
Tipping load straight *	lb (kg)	24334 (11038)	24101 (10932)	24334 (11038)	24101 (10932)	23514 (10666)	23215 (10530)	22619 (10260)	22402 (10162)	22619 (10260)	22402 (10162)	21873 (9921)	21589 (9793)
Tipping load full turn *	lb (kg)	20896 (9478)	20684 (9382)	20896 (9478)	20684 (9382)	20115 (9124)	19841 (9000)	19352 (8778)	19154 (8688)	19352 (8778)	19154 (8688)	18640 (8455)	18380 (8337)
Payload *	lb (kg)	10448 (4739)	10342 (4691)	10448 (4739)	10342 (4691)	10057 (4562)	9920 (4500)	9676 (4389)	9577 (4344)	9676 (4389)	9577 (4344)	9320 (4228)	9190 (4168)
Maximum breakout force	lbf (kN)	31024 (138)	28776 (128)	31024 (138)	28776 (128)	27651 (123)	25853 (115)	27202 (121)	25403 (113)	27202 (121)	25403 (113)	23830 (106)	22256 (99)
M Dump angle maximum	degrees	49	49	49	49	49	49	49	49	49	49	49	49
N Roll back angle full height	degrees	58	58	58	58	58	58	58	58	58	58	58	58
O Roll back at carry	degrees	48	48	48	48	48	48	48	48	48	48	48	48
P Roll back at ground level	degrees	43	43	43	43	43	43	43	43	43	43	43	43
Q Load over height	ft-in (mm)	11-11 (3627)	11-11 (3627)	11-10 (3612)	11-10 (3612)	11-10 (3610)	11-10 (3610)	11-11 (3627)	11-11 (3627)	11-10 (3612)	11-10 (3612)	11-10 (3610)	11-10 (3610)
R Dump height (45 deg dump)	ft-in (mm)	9-5 (2871)	9-1 (2767)	9-8 (2944)	9-6 (2896)	9-5 (2860)	9-2 (2796)	8-10 (2697)	8-8 (2647)	9-4 (2848)	9-1 (2775)	9-0 (2739)	8-9 (2676)
S Dig depth	ft-in (mm)	0-2 (50)	0-2 (50)	0-2 (47)	0-2 (47)	0-2 (47)	0-2 (47)	0-2 (50)	0-2 (50)	0-2 (47)	0-2 (47)	0-2 (47)	0-2 (47)
T Reach at dump height	ft-in (mm)	3-4 (1022)	3-6 (1072)	2-11 (897)	3-2 (963)	3-3 (979)	3-5 (1043)	3-5 (1142)	3-11 (1191)	3-3 (1003)	3-6 (1069)	3-7 (1100)	3-10 (1164)
V Pin height	ft-in (mm)	12-9 (3876)	12-9 (3876)	12-9 (3876)	12-9 (3876)	12-9 (3876)	12-9 (3876)	12-9 (3876)	12-9 (3876)	12-9 (3876)	12-9 (3876)	12-9 (3876)	12-9 (3876)
Reach maximum (45 deg dump) horizontal arm	ft-in (mm)	5-10 (1769)	6-0 (1819)	5-5 (1644)	5-7 (1694)	5-8 (1726)	5-10 (1790)	6-2 (1889)	6-4 (1938)	5-9 (1751)	5-11 (1816)	6-1 (1847)	6-3 (1911)
Operating weight (includes 165lbs (75kg) operator and full fuel and DEF tanks)	lb (kg)	29500 (13381)	29597 (13425)	29500 (13381)	59597 (13425)	30170 (13685)	30309 (13748)	30150 (13676)	30247 (13720)	30150 (13676)	30247 (13720)	30770 (13957)	30907 (14019)

*Assumes machine is fitted with Michelin 20.5XHA tires, 5 speed transmission and non parallel links.

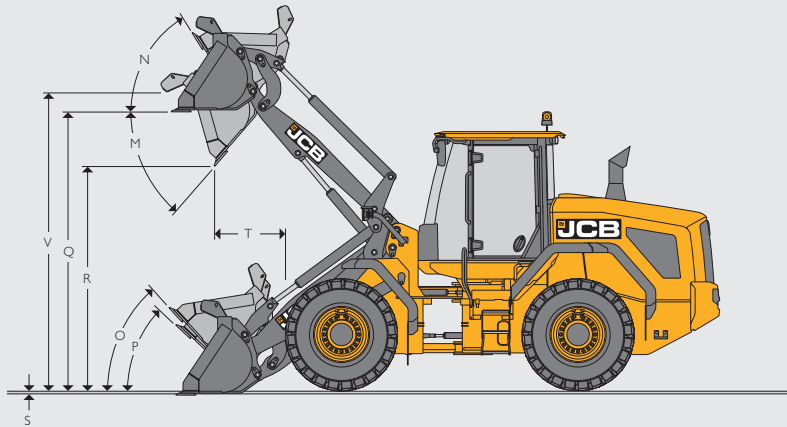

TIRE SIZE 427 HT HL

Tire size	Manufacturer	Type	Rating	Operating weight lbs (kg)	HT HL		Dimensions	
					STL lbs (kg)	FTTL lbs (kg)	Vertical in (mm)	Width in (mm)
20.5R25	Michelin	XHA2	L3	0 (0)	0 (0)	0 (0)	0.0 (0)	0.0 (0)
20.5R25	Michelin	XTLA	L2	-247 (-112)	-148 (-67)	-91 (-41)	-0.3 (-7)	0.2 (4)
20.5R25	Michelin	XLDD2A	L5	1155 (524)	694 (315)	423 (192)	1.2 (30)	0.2 (6)
20.5R25	Michelin	XMIND2	L5	1561 (708)	939 (426)	571 (259)	2.3 (58)	1.3 (34)
550/65R25	Michelin	XLDD2A	L3	-168 (-76)	-101 (-46)	-62 (-28)	-1.7 (-44)	0.8 (21)
20.5R25	Michelin	XSNOPPLUS	L2	-168 (-76)	-101 (-46)	-62 (-28)	-0.4 (-11)	0.2 (6)
620/75R26	Michelin	MEGAXBIB	N/A	-696 (-315.6)	-419 (-190)	-254 (-115)	2.7 (68)	4.3 (108)
650/65R25	Michelin	XLD	L3	1215 (551.2)	730 (331)	444 (202)	-0.4 (-10)	9.8 (249)
750/65R26	Michelin	MEGAXBIB	N/A	-146 (-66.4)	-88 (-40)	-54 (-24)	3.2 (81)	18.7 (474)
20.5-25	Goodyear	SGL (16 ply)	L2	-520 (-236)	-313 (-142)	-190 (-86)	-0.2 (-5)	0.2 (4)
20.5-25	Goodyear	HRL (16 ply)	L3	-53 (-24)	-31 (-14)	-19 (-9)	1.5 (37)	0.2 (4)
20.5R25	Goodyear	TL-3A+	L3	644 (292)	388 (176)	236 (107)	0.4 (11)	0.2 (4)
20.5R25	Goodyear	RL-5K	L5	1199 (544)	721 (327)	439 (199)	1.9 (49)	0.2 (4)
20.5R25	JCB	Earthmover	L3	203 (92)	121 (55)	75 (34)	1.6 (41)	0.5 (12)
20.5R25	SG Revolution	SE	Solid	4504 (2043.2)	2709 (1229)	1649 (748)	0.7 (17)	3.7 (95)
20.5R25	SG Revolution	S2 C2 DWL	Solid	4778 (2167.2)	2873 (1303)	1748 (793)	0.2 (6)	3.7 (95)
20.5-25	JCB	Sitemaster (16ply)	L3	-344 (-156)	-207 (-94)	-126 (-57)	0.8 (21)	-0.3 (-7)
20.5R25	Nokian	GRIP TL	L3	-441 (-200)	-265 (-120)	-162 (-73)	0.2 (4)	-0.3 (-7)

Heavy-duty axles (required with 5 speed and 750 width agricultural tires and high lift arms).

LOADER DIMENSIONS 427 HT HL

	Bucket mounting	Direct						Quickhitch					
		General purpose						General purpose					
		Tipped teeth		Reversible toeplate				Tipped teeth		Reversible toeplate			
Bucket capacity (SAE heaped 100%)	yd ³ (m ³)	2.35 (1.8)	2.62 (2)	2.49 (1.9)	2.75 (2.1)	3.14 (2.4)	3.53 (2.7)	2.35 (1.8)	2.62 (2)	2.49 (1.9)	2.75 (2.1)	3.14 (2.4)	3.53 (2.7)
Bucket capacity (struck)	yd ³ (m ³)	2.04 (1.556)	2.31 (1.765)	2.11 (1.616)	2.39 (1.83)	2.69 (2.057)	3.07 (2.346)	2.03 (1.554)	2.29 (1.749)	2.08 (1.594)	2.34 (1.787)	2.69 (2.057)	3.07 (2.346)
Bucket width	ft-in (mm)	8-4 (2550)	8-4 (2550)	8-4 (2550)	8-4 (2550)	8-10 (2700)	8-10 (2700)	8-4 (2550)	8-4 (2550)	8-4 (2550)	8-4 (2550)	8-10 (2700)	8-10 (2700)
Bucket weight	lb (kg)	2478 (810)	2643 (850)	2504 (810)	2670 (850)	2538 (1136)	2698 (1211)	2564 (800)	2725 (850)	2478 (800)	2643 (850)	2504 (1136)	2670 (1211)
Maximum material density *	lb/yd ³ (kg/m ³)	3740 (2219)	3332 (1977)	3543 (2102)	3174 (1883)	2688 (1595)	2356 (1398)	3469 (2058)	3090 (1833)	3285 (1949)	2943 (1746)	2493 (1479)	2184 (1296)
Tipping load straight *	lb (kg)	20538 (9316)	20343 (9228)	20538 (9316)	20343 (9228)	19778 (8971)	19524 (8856)	19130 (8677)	18954 (8598)	19130 (8677)	18954 (8598)	18427 (8358)	18182 (8247)
Tipping load full turn *	lb (kg)	17610 (7988)	17431 (7907)	17610 (7988)	17431 (7907)	16881 (7657)	16645 (7550)	16330 (7407)	16168 (7334)	16330 (7407)	16168 (7334)	15656 (7102)	15429 (6999)
Payload *	lb (kg)	8805 (3994)	8716 (3953)	8805 (3994)	8716 (3953)	8440 (3828)	8323 (3775)	8165 (3704)	8084 (3667)	8165 (3704)	8084 (3667)	7828 (3551)	7715 (3499)
Maximum breakout force	lbf (kN)	31024 (138)	28776 (128)	31024 (138)	28776 (128)	27651 (123)	25853 (115)	27202 (121)	25403 (113)	27202 (121)	25403 (113)	23830 (106)	22256 (99)
M Dump angle maximum	degrees	45	45	45	45	45	45	45	45	45	45	45	45
N Roll back angle full height	degrees	58	58	58	58	58	58	58	58	58	58	58	58
O Roll back at carry	degrees	50	50	50	50	50	50	50	50	50	50	50	50
P Roll back at ground level	degrees	48	48	48	48	48	48	48	48	48	48	48	48
Q Load over height	ft-in (mm)	13-4 (4057)	13-4 (4057)	13-3 (4042)	13-3 (4042)	13-3 (4040)	13-3 (4040)	13-4 (4057)	13-4 (4057)	13-3 (4042)	13-3 (4042)	13-3 (4040)	13-3 (4040)
R Dump height (45 deg dump)	ft-in (mm)	10-8 (3247)	10-6 (3197)	10-6 (3374)	10-11 (3326)	10-10 (3290)	10-7 (3226)	10-6 (3212)	10-3 (3127)	10-9 (3278)	10-6 (3205)	10-5 (3169)	10-2 (3106)
S Dig depth	ft-in (mm)	0-4 (113)	0-4 (113)	0-4 (110)	0-4 (110)	0-4 (110)	0-4 (110)	0-5 (128)	0-4 (113)	0-4 (110)	0-4 (110)	0-4 (110)	0-4 (110)
T Reach at dump height	ft-in (mm)	3-11 (1184)	6-4 (1934)	3-6 (1059)	3-8 (1109)	3-9 (1141)	3-11 (1205)	3-11 (1195)	3-11 (1204)	3-10 (1165)	4-0 (1231)	4-2 (1262)	4-4 (1326)
V Pin height	ft-in (mm)	14-2 (4306)	14-2 (4306)	14-2 (4306)	14-2 (4306)	14-2 (4306)	14-2 (4306)	14-2 (4306)	14-2 (4306)	14-2 (4306)	14-2 (4306)	14-2 (4306)	14-2 (4306)
Reach maximum (45 deg dump) horizontal arm	ft-in (mm)	7-1 (2117)	7-1 (2167)	6-6 (1992)	6-8 (2042)	6-10 (2074)	7-0 (2138)	7-0 (2128)	7-4 (2237)	6-11 (2099)	7-1 (2164)	7-2 (2195)	7-5 (2259)
Operating weight (includes 165lbs (75kg) operator and full fuel and DEF tanks)	lb (kg)	30060 (13591)	30060 (13635)	29963 (13591)	30060 (13635)	30633 (13895)	30772 (13958)	30613 (13886)	30710 (13930)	30613 (13886)	30710 (13930)	31233 (14167)	31370 (14229)

*Assumes machine is fitted with Michelin 20.5XHA tires, 5 speed transmission and non parallel links.

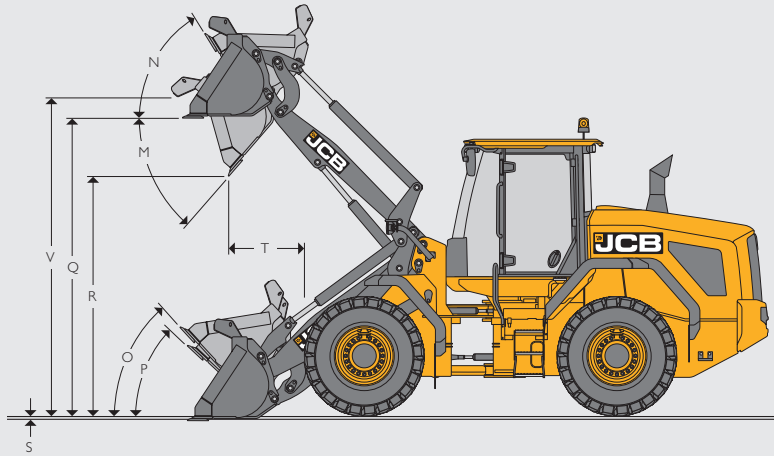

TIRE SIZE 437 HT

Tire size	Manufacturer	Type	Rating	Operating weight lbs (kg)	HT		Dimensions	
					STL lbs (kg)	FTTL lbs (kg)	Vertical in (mm)	Width in (mm)
20.5R25	Michelin	XHA	L3	0 (0)	0 (0)	0 (0)	0 (0)	0 (0)
20.5R25	Michelin	XTLA	L2	-247 (-112)	-165 (-75)	-143 (-65)	-0.3 (-7)	0.2 (4)
550/65R25	Michelin	XLD	L5	-168 (-76)	-112 (-51)	-97 (-44)	-1.7 (-44)	0.8 (21)
20.5R25	Michelin	XSNOPPLUS	L5	-168 (-76)	-112 (-51)	-97 (-44)	-0.4 (-11)	0.2 (6)
20.5R25	Michelin	XLDD2A	L3	1155 (524)	776 (352)	670 (304)	1.2 (30)	0.2 (6)
20.5R25	Michelin	XMINED2	L2	1561 (708)	1047 (475)	906 (411)	2.3 (58)	1.3 (34)
620/75R26	Michelin	MEGAXBIB	N/A	-703 (-318.8)	-472 (-214)	-408 (-185)	2.7 (68)	-0.3 (-7)
650/65R25	Michelin	XLD	L3	1208 (548)	811 (368)	701 (318)	-0.4 (-10)	5.3 (134)
750/65R26	Michelin	MEGAXBIB	N/A	-153 (-69.6)	-104 (-47)	-88 (-40)	3.2 (81)	14.1 (359)
20.5-25	Goodyear	SGL (16 ply)	L2	-397 (-180)	-267 (-121)	-229 (-104)	-0.2 (-5)	1.0 (26)
20.5R25	Goodyear	TL-3A+	L3	644 (292)	432 (196)	373 (169)	0.4 (11)	0.7 (17)
20.5R25	Goodyear	RL-5K	L3	1358 (616)	911 (413)	787 (357)	1.9 (49)	1.0 (26)
20.5-25	Goodyear	HRL (16 ply)	L5	-53 (-24)	-35 (-16)	-31 (-14)	1.5 (37)	1.0 (26)
20.5R25	JCB	Earthmover	L3	203 (92)	137 (62)	117 (53)	1.6 (41)	0.5 (12)
20.5R25	SG Revolution	SE	N/A	4497 (2040)	3018 (1369)	2608 (1183)	0.7 (17)	-0.8 (-20)
20.5R25	SG Revolution	S2 C2 DWL	N/A	4771 (2164)	3201 (1452)	2767 (1255)	0.2 (6)	-0.8 (-20)
20.5-25	JCB	Stemaster (16ply)	L3	220 (100)	148 (67)	128 (58)	0.8 (21)	-0.3 (-7)
20.5R25	Nokian	GRIP TL	L3	-441 (-200)	-295 (-134)	-256 (-116)	0.2 (4)	-0.3 (-7)

Heavy-duty axles (required with 5 speed and 750 width agricultural tires and high lift arms).

LOADER DIMENSIONS 437 HT

		Direct				Quickhitch			
		General purpose				General purpose			
		Tipped teeth		Reversible toeplate		Tipped teeth		Reversible toeplate	
Bucket mounting									
Bucket type									
Bucket equipment									
Bucket capacity (SAE heaped 100%)	yd³ (m³)	3.01 (2.3)	3.4 (2.6)	3.14 (2.4)	3.53 (2.7)	3.01 (2.3)	3.4 (2.6)	3.14 (2.4)	3.53 (2.7)
Bucket capacity (struck)	yd³ (m³)	2.59 (1.984)	2.97 (2.27)	2.69 (2.057)	3.07 (2.346)	2.59 (1.984)	2.97 (2.27)	2.69 (2.057)	3.07 (2.346)
Bucket width	ft-in (mm)	9-0 (2740)	9-0 (2740)	8-10 (2700)	8-10 (2700)	9-0 (2740)	9-0 (2740)	8-10 (2700)	8-10 (2700)
Bucket weight	lb (kg)	2538 (1151)	2698 (1224)	2564 (1163)	2725 (1236)	2478 (1124)	2643 (1199)	2504 (1136)	2670 (1211)
Maximum material density *	lb/yd³ (kg/m³)	3610 (2142)	3154 (1871)	3460 (2053)	3036 (1801)	3359 (1993)	2933 (1740)	3219 (1910)	2825 (1676)
Tipping load straight *	lb (kg)	25519 (11575)	25214 (11437)	25519 (11575)	25214 (11437)	23834 (10811)	23545 (10680)	23834(10811)	23545 (10680)
Tipping load full turn *	lb (kg)	21724 (9854)	21449 (9729)	21724 (9854)	21449 (9729)	20219 (9171)	19954 (9051)	20219 (9171)	19954 (9051)
Payload *	lb (kg)	10862 (4927)	10723 (4864)	10862 (4927)	10723 (4864)	10108 (4585)	9976 (4525)	10108 (4585)	9976 (4525)
Maximum breakout force	lbf (kN)	33047 (147)	30124 (134)	33047 (147)	30124 (134)	29450 (131)	27427 (122)	29450 (131)	27427 (122)
M Dump angle maximum	degrees	49	49	49	49	49	49	49	49
N Roll back angle full height	degrees	58	58	58	58	58	58	58	58
O Roll back at carry	degrees	48	48	48	48	48	48	48	48
P Roll back at ground level	degrees	43	43	43	43	43	43	43	43
Q Load over height	ft-in (mm)	12-4 (3760)	12-4 (3760)	12-4 (3755)	12-4 (3755)	12-4 (3760)	12-4 (3760)	12-4 (3755)	12-4 (3755)
R Dump height (45 deg dump)	ft-in (mm)	9-2 (2794)	8-11 (2730)	9-9 (2962)	9-5 (2871)	8-11 (2709)	8-8 (2645)	9-4 (2850)	9-2 (2786)
S Dig depth	ft-in (mm)	0-5 (132)	0-5 (132)	0-4 (106)	0-4 (106)	0-5 (132)	0-5 (132)	0-4 (106)	0-4 (106)
T Reach at dump height	ft-in (mm)	3-8 (1115)	3-10 (1174)	3-4 (1011)	3-6 (1070)	3-11 (1192)	4-1 (1250)	3-7 (1088)	3-9 (1146)
V Pin height	ft-in (mm)	13-2 (4021)	13-2 (4021)	13-2 (4021)	13-2 (4021)	13-2 (4021)	13-2 (4021)	13-2 (4021)	13-2 (4021)
Reach maximum (45 deg dump) horizontal arm	ft-in (mm)	6-5 (1954)	6-7 (2018)	6-1 (1850)	6-3 (1914)	5-8 (1739)	6-11 (2103)	6-4 (1935)	6-7 (1999)
Operating weight (includes 165lbs (75kg) operator and full fuel and DEF tanks)	lb (kg)	33272 (15092)	33411 (15155)	33272 (15092)	33411 (15155)	33872 (15364)	34009 (15426)	33872 (15364)	34009 (15426)

*Assumes machine is fitted with Michelin 20.5R25 XHA2 (L3) tires, 5 speed transmission and non parallel links.

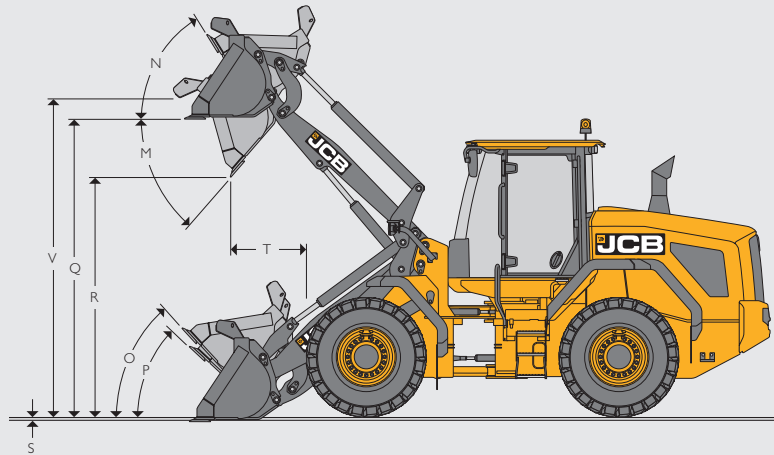

TIRE SIZE 437 HT HL

Tire size	Manufacturer	Type	Rating	Operating weight lbs (kg)	HT HL		Dimensions	
					STL lbs (kg)	FTTL lbs (kg)	Vertical in (mm)	Width in (mm)
20.5R25	Michelin	XHA	L3	0 (0)	0 (0)	0 (0)	0 (0)	0 (0)
20.5R25	Michelin	XTLA	L2	-247 (-112)	-135 (-61)	-78 (-35)	-0.3 (-7)	0.2 (4)
550/65R25	Michelin	XLD	L5	-168 (-76)	-91 (-42)	-53 (-24)	-1.7 (-44)	0.8 (21)
20.5R25	Michelin	XSNOPPLUS	L5	-168 (-76)	-91 (-42)	-53 (-24)	-0.4 (-11)	0.2 (6)
20.5R25	Michelin	XLDD2A	L3	1155 (524)	631 (286)	366 (166)	1.2 (30)	0.2 (6)
20.5R25	Michelin	XMINED2	L2	1561 (708)	852 (387)	494 (224)	2.3 (58)	1.3 (34)
620/75R26	Michelin	MEGAXBIB	N/A	-703 (-318.8)	-384 (-174)	-223 (-101)	2.7 (68)	-0.3 (-7)
650/65R25	Michelin	XLD	L3	1208 (548)	659 (299)	383 (174)	-0.4 (-10)	5.3 (134)
750/65R26	Michelin	MEGAXBIB	N/A	-153 (-69.6)	-84 (-38)	-49 (-22)	3.2 (81)	14.1 (359)
20.5-25	Goodyear	SGL (16 ply)	L2	-397 (-180)	-217 (-98)	-126 (-57)	-0.2 (-5)	1.0 (26)
20.5R25	Goodyear	TL-3A+	L3	644 (292)	351 (159)	204 (93)	0.4 (11)	0.7 (17)
20.5R25	Goodyear	RL-5K	L3	1358 (616)	741 (336)	429 (195)	1.9 (49)	1.0 (26)
20.5-25	Goodyear	HRL (16 ply)	L5	-53 (-24)	-29 (-13)	-17 (-8)	1.5 (37)	1.0 (26)
20.5R25	JCB	Earthmover	L3	203 (92)	111 (50)	64 (29)	1.6 (41)	0.5 (12)
20.5R25	SG Revolution	SE	N/A	4497 (2040)	2455 (1114)	1424 (646)	0.7 (17)	-0.8 (-20)
20.5R25	SG Revolution	S2 C2 DWL	N/A	4771 (2164)	2604 (1181)	1510 (685)	0.2 (6)	-0.8 (-20)
20.5-25	JCB	Stemaster (16ply)	L3	220 (100)	120 (55)	70 (32)	0.8 (21)	-0.3 (-7)
20.5R25	Nokian	GRIP TL	L3	-441 (-200)	-241 (-109)	-139 (-63)	0.2 (4)	-0.3 (-7)

Heavy-duty axles (required with 5 speed and 750 width agricultural tires and high lift arms).

LOADER DIMENSIONS 437 HT HL

		Direct				Quickhitch			
		General purpose				General purpose			
		Tipped teeth		Reversible toeplate		Tipped teeth		Reversible toeplate	
Bucket mounting									
Bucket type									
Bucket equipment									
Bucket capacity (SAE heaped 100%)	yd ³ (m ³)	3.01 (2.3)	3.4 (2.6)	3.14 (2.4)	3.53 (2.7)	3.01 (2.3)	3.4 (2.6)	3.14 (2.4)	3.53 (2.7)
Bucket capacity (struck)	yd ³ (m ³)	2.59 (1.984)	2.97 (2.27)	2.69 (2.057)	3.07 (2.346)	2.59 (1.984)	2.97 (2.27)	2.69 (2.057)	3.07 (2.346)
Bucket width	ft-in (mm)	9-0 (2740)	9-0 (2740)	8-10 (2700)	8-10 (2700)	9-0 (2740)	9-0 (2740)	8-10 (2700)	8-10 (2700)
Bucket weight	lb (kg)	2538 (1151)	2698 (1224)	2564 (1163)	2725 (1236)	2478 (1124)	2643 (1199)	2504 (1136)	2670 (1211)
Maximum material density *	lb/yd ³ (kg/m ³)	2901 (1721)	2533 (1503)	2781 (1650)	2441 (1448)	2709 (1607)	2365 (1403)	2596 (1540)	2277 (1351)
Tipping load straight *	lb (kg)	20578 (9334)	20338 (9225)	20578 (9334)	20338 (9225)	19295 (8752)	19063 (8647)	19295 (8752)	19063 (8647)
Tipping load full turn *	lb (kg)	17456 (7918)	17236 (7818)	17456 (7918)	17236 (7818)	16294 (7391)	16078 (7293)	16294 (7391)	16078 (7293)
Payload *	lb (kg)	8728 (3959)	8618 (3909)	8728 (3959)	8618 (3909)	8148 (3696)	8040 (3647)	8148 (3696)	8040 (3647)
Maximum breakout force	lbf (kN)	33047 (147)	30124 (134)	33047 (147)	30124 (134)	29450 (131)	27427 (122)	29450 (131)	27427 (122)
M Dump angle maximum	degrees	45	45	45	45	45	45	45	45
N Roll back angle full height	degrees	60	60	60	60	60	60	60	60
O Roll back at carry	degrees	54	54	54	54	54	54	54	54
P Roll back at ground level	degrees	45	45	45	45	45	45	45	45
Q Load over height	ft-in (mm)	14-6 (4414)	14-6 (4414)	14-6 (4409)	14-6 (4409)	14-6 (4414)	14-6 (4414)	14-6 (4409)	14-6 (4409)
R Dump height (45 deg dump)	ft-in (mm)	11-4 (3448)	11-1 (3384)	11-10 (3616)	11-7 (3525)	11-0 (3363)	10-10 (3299)	11-6 (3504)	11-3 (3440)
S Dig depth	ft-in (mm)	0-5 (127)	0-5 (127)	0-4 (101)	0-4 (101)	0-5 (127)	0-5 (127)	0-4 (101)	0-4 (101)
T Reach at dump height	ft-in (mm)	3-8 (1115)	3-10 (1174)	3-4 (1011)	3-6 (1070)	3-11 (1192)	4-1 (1250)	3-7 (1088)	3-9 (1146)
V Pin height	ft-in (mm)	15-4 (4675)	15-4 (4675)	15-4 (4675)	15-4 (4675)	15-4 (4675)	15-4 (4675)	15-4 (4675)	15-4 (4675)
Reach maximum (45 deg dump) horizontal arm	ft-in (mm)	8-0 (2444)	8-3 (2508)	7-8 (2340)	7-11 (2404)	7-4 (2229)	8-6 (2593)	7-11 (2425)	8-2 (2489)
Operating weight (includes 165lbs (75kg) operator and full fuel and DEF tanks)	lb (kg)	34196 (15511)	34335 (15574)	34196 (15511)	34335 (15574)	34796 (15783)	34932 (15845)	34796 (15783)	34932 (15845)

*Assumes machine is fitted with Michelin 20.5R25 XHA2 (L3) tires, 5 speed transmission and non parallel links.

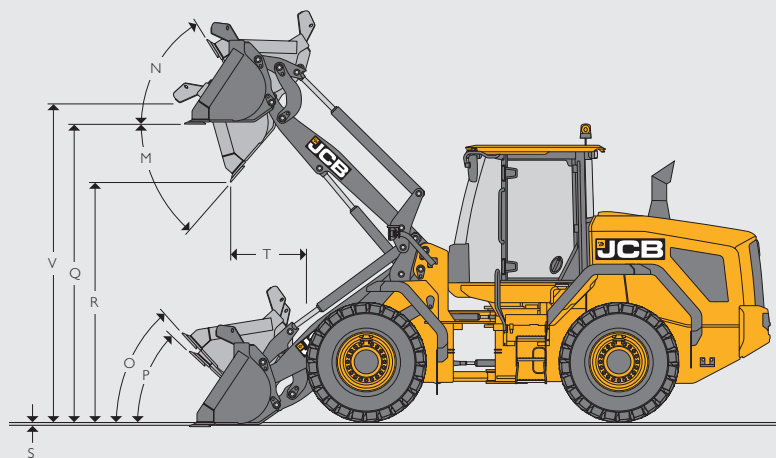

TIRE SIZE 437 HT SHL

Tire size	Manufacturer	Type	Rating	Operating weight lbs (kg)	HT SHL		Dimensions	
					STL lbs (kg)	FTTL lbs (kg)	Vertical in (mm)	Width in (mm)
20.5R25	Michelin	XHA	L3	0 (0)	0 (0)	0 (0)	0 (0)	0 (0)
20.5R25	Michelin	XTLA	L2	-247 (-112)	-77 (-35)	-54 (-24)	-0.3 (-7)	0.2 (4)
550/65R25	Michelin	XLD	L5	-168 (-76)	-52 (-24)	-37 (-17)	-1.7 (-44)	0.8 (21)
20.5R25	Michelin	XSNOPPLUS	L5	-168 (-76)	-52 (-24)	-37 (-17)	-0.4 (-11)	0.2 (6)
20.5R25	Michelin	XLDD2A	L3	1155 (524)	359 (163)	252 (114)	1.2 (30)	0.2 (6)
20.5R25	Michelin	XMINED2	L2	1561 (708)	485 (220)	341 (155)	2.3 (58)	1.3 (34)
620/75R26	Michelin	MEGAXBIB	N/A	-703 (-318.8)	-218 (-99)	-153 (-70)	2.7 (68)	-0.3 (-7)
650/65R25	Michelin	XLD	L3	1208 (548)	376 (170)	264 (120)	-0.4 (-10)	5.3 (134)
750/65R26	Michelin	MEGAXBIB	N/A	-153 (-69.6)	-48 (-22)	-34 (-15)	3.2 (81)	14.1 (359)
20.5-25	Goodyear	SGL (16 ply)	L2	-397 (-180)	-123 (-56)	-87 (-39)	-0.2 (-5)	1.0 (26)
20.5R25	Goodyear	TL-3A+	L3	644 (292)	200 (91)	141 (64)	0.4 (11)	0.7 (17)
20.5R25	Goodyear	RL-5K	L3	1358 (616)	422 (191)	297 (135)	1.9 (49)	1.0 (26)
20.5-25	Goodyear	HRL (16 ply)	L5	-53 (-24)	-16 (-7)	-11 (-5)	1.5 (37)	1.0 (26)
20.5R25	JCB	Earthmover	L3	203 (92)	63 (29)	44 (20)	1.6 (41)	0.5 (12)
20.5R25	SG Revolution	SE	N/A	4497 (2040)	1398 (634)	982 (446)	0.7 (17)	-0.8 (-20)
20.5R25	SG Revolution	S2 C2 DWL	N/A	4771 (2164)	1482 (672)	1042 (473)	0.2 (6)	-0.8 (-20)
20.5-25	JCB	Sitemaster (16ply)	L3	220 (100)	68 (31)	48 (22)	0.8 (21)	-0.3 (-7)
20.5R25	Nokian	GRIP TL	L3	-441 (-200)	-137 (-62)	-96 (-44)	0.2 (4)	-0.3 (-7)

Heavy-duty axles (required with 5 speed and 750 width agricultural tires and high lift arms).

LOADER DIMENSIONS 437 HT SHL

		Direct				Quickhitch			
		General purpose				General purpose			
		Tipped teeth		Reversible toeplate		Tipped teeth		Reversible toeplate	
Bucket mounting									
Bucket type									
Bucket equipment									
Bucket capacity (SAE heaped 100%)	yd ³ (m ³)	3.01 (2.3)	3.4 (2.6)	3.14 (2.4)	3.53 (2.7)	3.01 (2.3)	3.4 (2.6)	3.14 (2.4)	3.53 (2.7)
Bucket capacity (struck)	yd ³ (m ³)	2.59 (1.984)	2.97 (2.27)	2.69 (2.057)	3.07 (2.346)	2.59 (1.984)	2.97 (2.27)	2.69 (2.057)	3.07 (2.346)
Bucket width	ft-in (mm)	9-0 (2740)	9-0 (2740)	8-10 (2700)	8-10 (2700)	9-0 (2740)	9-0 (2740)	8-10 (2700)	8-10 (2700)
Bucket weight	lb (kg)	2538 (1151)	2698 (1224)	2564 (1163)	2725 (1236)	2478 (1124)	2643 (1199)	2504 (1136)	2670 (1211)
Maximum material density *	lb/yd ³ (kg/m ³)	2124 (1260)	1849 (1097)	2036 (1208)	1780 (1056)	1960 (1163)	1706 (1012)	1879 (1115)	1642 (974)
Tipping load straight *	lb (kg)	15177 (6884)	14952 (6782)	15177 (6884)	14952 (6782)	14105 (6398)	13887 (6299)	14105 (6398)	13887 (6299)
Tipping load full turn *	lb (kg)	12782 (5798)	12571 (5702)	12782 (5798)	12571 (5702)	11801 (5353)	11596 (5260)	11801 (5353)	11596 (5260)
Payload *	lb (kg)	6391 (2899)	6285 (2851)	6391 (2899)	6285 (2851)	5900 (2676)	5798 (2630)	5900 (2676)	5798 (2630)
Maximum breakout force	lbf (kN)	34396 (153)	31248 (139)	34396 (153)	31248 (139)	30574 (136)	27876 (124)	30574 (136)	28551 (127)
M Dump angle maximum	degrees	50	50	50	50	50	50	50	50
N Roll back angle full height	degrees	58	58	58	58	58	58	58	58
O Roll back at carry	degrees	48	48	48	48	48	48	48	48
P Roll back at ground level	degrees	43	43	43	43	43	43	43	43
Q Load over height	ft-in (mm)	16-4 (4981)	16-4 (4981)	16-4 (4976)	16-4 (4976)	16-4 (4981)	16-4 (4981)	16-4 (4976)	16-4 (4976)
R Dump height (45 deg dump)	ft-in (mm)	13-2 (4011)	12-11 (3947)	13-9 (4179)	13-5 (4088)	12-11 (3926)	12-8 (3862)	13-4 (4067)	13-2 (4003)
S Dig depth	ft-in (mm)	0-4 (105)	0-4 (105)	0-3 (79)	0-3 (79)	0-4 (105)	0-4 (105)	0-3 (79)	0-3 (79)
T Reach at dump height	ft-in (mm)	3-9 (1139)	3-11 (1198)	3-5 (1035)	3-7 (1094)	4-0 (1216)	4-2 (1274)	3-8 (1112)	3-11 (1197)
V Pin height	ft-in (mm)	17-2 (5242)	17-2 (5242)	17-2 (5242)	17-2 (5242)	17-2 (5242)	17-2 (5242)	17-2 (5242)	17-2 (5242)
Reach maximum (45 deg dump) horizontal arm	ft-in (mm)	9-7 (2919)	9-9 (2983)	9-3 (2815)	9-5 (2879)	8-10 (2704)	10-1 (3068)	9-6 (2900)	9-9 (2964)
Operating weight (includes 165lbs (75kg) operator and full fuel and DEF tanks)	lb (kg)	35188 (15961)	35327 (16024)	35188 (15961)	35327 (16024)	35788 (16233)	35924 (16295)	35788 (16233)	35924 (16295)

*Assumes machine is fitted with Michelin 20.5R25 XHA2 (L3) tires, 5 speed transmission and non parallel links.

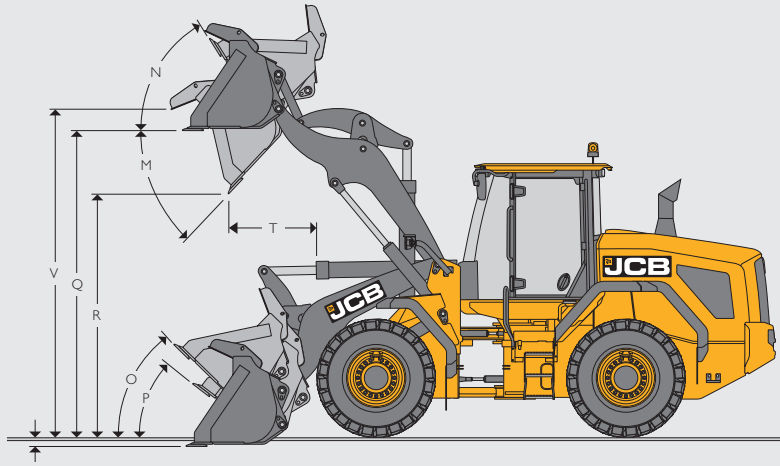

TIRE SIZE 427 ZX

Tire size	Manufacturer	Type	Rating	Operating weight lbs (kg)	ZX		Dimensions	
					STL lbs (kg)	FTTL lbs (kg)	Vertical in (mm)	Width in (mm)
20.5R25	Michelin	XHA2	L3	0 (0)	0 (0)	0 (0)	0.0 (0)	0.0 (0)
20.5R25	Michelin	XTLA	L2	-247 (-112)	-165 (-75)	-143 (-65)	-0.3 (-7)	0.2 (4)
20.5R25	Michelin	XLDD2A	L5	1155 (524)	776 (352)	670 (304)	1.2 (30)	0.2 (6)
20.5R25	Michelin	XMINED2	L5	1561 (708)	1047 (475)	906 (411)	2.3 (58)	1.3 (34)
550/65R25	Michelin	XLD	L3	-168 (-76)	-112 (-51)	-97 (-44)	-1.7 (-44)	0.8 (21)
20.5R25	Michelin	XSNOPPLUS	L2	-168 (-76)	-112 (-51)	-97 (-44)	-0.4 (-11)	0.2 (6)
620/75R26	Michelin	MEGAXBIB	N/A	-696 (-315.6)	-467 (-212)	-403 (-183)	2.7 (68)	4.3 (108)
650/65R25	Michelin	XLD	L3	1215 (551.2)	816 (370)	705 (320)	-0.4 (-10)	9.8 (249)
750/65R26	Michelin	MEGAXBIB	N/A	-146 (-66.4)	-99 (-45)	-86 (-39)	3.2 (81)	18.7 (474)
20.5-25	Goodyear	SGL (16 ply)	L2	-520 (-236)	-348 (-158)	-302 (-137)	-0.2 (-5)	0.2 (4)
20.5-25	Goodyear	HRL (16 ply)	L3	-53 (-24)	-35 (-16)	-31 (-14)	1.5 (37)	0.2 (4)
20.5R25	Goodyear	TL-3A+	L3	644 (292)	432 (196)	373 (169)	0.4 (11)	0.2 (4)
20.5R25	Goodyear	RL-5K	L5	1199 (544)	805 (365)	697 (316)	1.9 (49)	0.2 (4)
20.5R25	JCB	Earthmover	L3	203 (92)	137 (62)	117 (53)	1.6 (41)	0.5 (12)
20.5R25	SG Revolution	SE	Solid	4504 (2043.2)	3023 (1371)	2612 (1185)	0.7 (17)	3.7 (95)
20.5R25	SG Revolution	S2 C2 DWL	Solid	4778 (2167.2)	3206 (1454)	2771 (1257)	0.2 (6)	3.7 (95)
20.5-25	JCB	Sitemaster (16ply)	L3	-344 (-156)	-231 (-105)	-198 (-90)	0.8 (21)	-0.3 (-7)
20.5R25	Nokian	GRIP TL	L3	-441 (-200)	-295 (-134)	-256 (-116)	0.2 (4)	-0.3 (-7)

LOADER DIMENSIONS 427 ZX

		Direct						Quickhitch					
		General purpose						General purpose					
		Tipped teeth		Reversible toeplate				Tipped teeth		Reversible toeplate			
Bucket mounting		Direct						Quickhitch					
Bucket type		General purpose						General purpose					
Bucket equipment		Tipped teeth		Reversible toeplate				Tipped teeth		Reversible toeplate			
Bucket capacity (SAE heaped 100%)	yd ³ (m ³)	2.62 (2)	2.62 (2)	2.49 (1.9)	2.75 (2.1)	3.14 (2.4)	3.53 (2.7)	2.35 (1.8)	2.62 (2)	2.49 (1.9)	2.75 (2.1)	3.14 (2.4)	3.53 (2.7)
Bucket capacity (struck)	yd ³ (m ³)	2.25 (1.724)	2.25 (1.724)	2.11 (1.612)	2.33 (1.785)	2.69 (2.057)	3.07 (2.346)	2.03 (1.554)	2.29 (1.749)	2.08 (1.594)	2.34 (1.787)	2.69 (2.057)	3.07 (2.346)
Bucket width	ft-in (mm)	8-4 (2550)	8-4 (2550)	8-4 (2550)	8-4 (2550)	8-10 (2700)	8-10 (2700)	8-4 (2550)	8-4 (2550)	8-4 (2550)	8-4 (2550)	8-10 (2700)	8-10 (2700)
Bucket weight	lb (kg)	1360.27 (1040)	1360.27 (1140)	1209.85 (925)	1360.27 (1040)	1650.63 (1262)	1738.27 (1329)	1046.36 (800)	1111.76 (850)	1046.36 (800)	1111.76 (850)	1485.83 (1136)	1583.93 (1211)
Maximum material density *	lb/yd ³ (kg/m ³)	3739 (2218)	3659 (2171)	3980 (2361)	3560 (2112)	3021 (1792)	2648 (1571)	3863 (2292)	3439 (2040)	3661 (2172)	3275 (1943)	2786 (1653)	2439 (1447)
Tipping load straight *	lb (kg)	22746 (10318)	22746 (10126)	22987 (10427)	22746 (10318)	22128 (10037)	21842 (9907)	21244 (9636)	21026 (9537)	21244 (9636)	21026 (9537)	20510 (9303)	20225 (9174)
Tipping load full turn *	lb (kg)	19559 (8872)	19559 (8684)	19777 (8971)	19559 (8872)	18966 (8603)	18702 (8483)	18193 (8252)	17993 (8162)	18193 (8252)	17993 (8162)	17491 (7934)	17228 (7814)
Payload *	lb (kg)	9780 (4436)	9780 (4342)	9888 (4485)	9780 (4436)	9483 (4301)	9351 (4241)	9096 (4126)	8997 (4081)	9096 (4126)	8997 (4081)	8746 (3967)	8614 (3907)
Maximum breakout force	lbf (kN)	30349 (135)	30349 (135)	32597 (145)	30349 (135)	29000 (129)	26977 (120)	28326 (126)	26527 (118)	28326 (126)	26527 (118)	25403 (113)	23830 (106)
M Dump angle maximum	degrees	45	45	45	45	45	45	45	45	45	45	45	45
N Roll back angle full height	degrees	52	52	52	52	52	52	52	52	52	52	52	52
O Roll back at carry	degrees	44	44	44	44	44	44	44	44	44	44	44	44
P Roll back at ground level	degrees	35	35	35	35	35	35	35	35	35	35	35	35
Q Load over height	ft-in (mm)	12-0 (3645)	12-0 (3645)	11-11 (3640)	11-11 (3640)	11-11 (3638)	11-11 (3638)	12-0 (3645)	12-0 (3645)	11-11 (3640)	11-11 (3640)	11-11 (3638)	11-11 (3638)
R Dump height (45 deg dump)	ft-in (mm)	9-2 (2797)	9-2 (2797)	9-9 (2973)	9-7 (2925)	9-6 (2889)	9-3 (2825)	8-11 (2726)	8-10 (2694)	9-4 (2852)	9-2 (2804)	9-1 (2768)	8-10 (2704)
S Dig depth	ft-in (mm)	0-1 (33)	0-1 (33)	0-1 (30)	0-1 (30)	0-1 (32)	0-1 (32)	0-1 (33)	0-1 (33)	0-1 (30)	0-1 (30)	0-1 (32)	0-1 (32)
T Reach at dump height	ft-in (mm)	3-8 (1111)	3-8 (1111)	3-1 (936)	3-3 (986)	3-4 (1019)	3-7 (1083)	3-11 (1182)	4-1 (1232)	3-6 (1057)	3-8 (1107)	3-9 (1140)	3-11 (1204)
V Pin height	ft-in (mm)	12-10 (3904)	12-10 (3904)	12-1 (3904)	12-10 (3904)	12-10 (3904)	12-10 (3904)	12-10 (3904)	12-10 (3904)	12-10 (3904)	12-10 (3904)	12-1 (3904)	12-10 (3904)
Reach maximum (45 deg dump) horizontal arm	ft-in (mm)	6-1 (1858)	6-1 (1858)	5-6 (1683)	5-8 (1733)	5-10 (1766)	6-0 (1830)	6-4 (1929)	6-6 (1979)	5-11 (1804)	6-1 (1854)	6-3 (1907)	6-5 (1951)
Operating weight (includes 165lbs (75kg) operator and full fuel and DEF tanks)	lb (kg)	30175 (13687)	30175 (13866)	30102 (13654)	30175 (13687)	30708 (13929)	30858 (13997)	30900 (14016)	30997 (14060)	30900 (14016)	30997 (14060)	31519 (14297)	31656 (14359)

*Assumes machine is fitted with Michelin 20.5R25 XHA2 (L3) tires and 5 speed transmission.

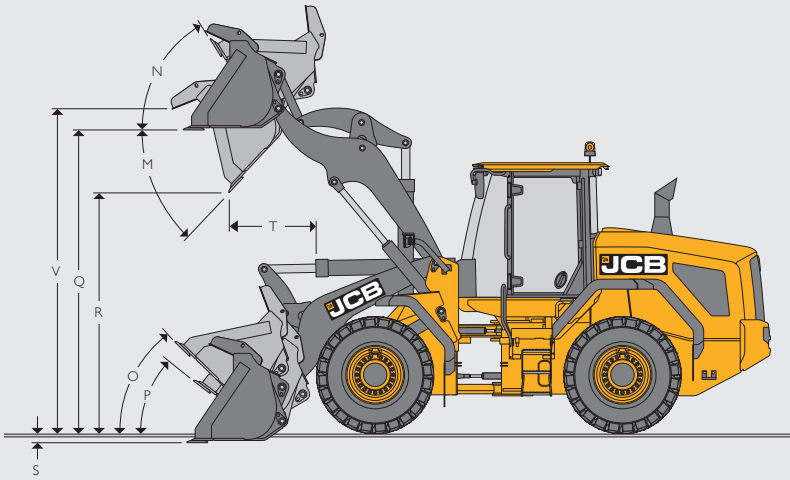

TIRE SIZE 437 ZX

Tire size	Manufacturer	Type	Rating	Operating weight lbs (kg)	ZX		Dimensions	
					STL lbs (kg)	FTTL lbs (kg)	Vertical in (mm)	Width in (mm)
20.5R25	Michelin	XHA	L3	0 (0)	0 (0)	0 (0)	0.0 (0)	0.0 (0)
20.5R25	Michelin	XTLA	L2	-247 (-112)	-134 (-61)	-117 (-53)	-0.3 (-7)	0.2 (4)
550/65R25	Michelin	XLD	L3	-168 (-76)	-90 (-41)	-79 (-36)	-1.7 (-44)	0.8 (21)
20.5R25	Michelin	XSNOPPLUS	L2	-168 (-76)	-90 (-41)	-79 (-36)	-0.4 (-11)	0.2 (6)
20.5R25	Michelin	XLDD2A	L5	1155 (524)	631 (286)	545 (247)	1.2 (30)	0.2 (6)
20.5R25	Michelin	XMINED2	L5	1561 (708)	851 (386)	736 (334)	2.3 (58)	1.3 (34)
620/75R26	Michelin	MEGAXBIB	N/A	-703 (-318.8)	-384 (-174)	-331 (-150)	2.7 (68)	-0.3 (-7)
650/65 R25	Michelin	XLD	L3	1208 (548)	659 (299)	571 (259)	-0.4 (-10)	5.3 (134)
750/65 R26	Michelin	MEGAXBIB	N/A	-153 (-69.6)	-84 (-38)	-73 (-33)	3.2 (81)	14.1 (359)
20.5-25	Goodyear	SGL (16 ply)	L2	-397 (-180)	-216 (-98)	-187 (-85)	-0.2 (-5)	1.0 (26)
20.5R25	Goodyear	TL-3A+	L3	644 (292)	351 (159)	304 (138)	0.4 (11)	0.7 (17)
20.5R25	Goodyear	RL-5K	L5	1358 (616)	741 (336)	642 (291)	1.9 (49)	1.0 (26)
20.5-25	Goodyear	HRL (16 ply)	L3	-53 (-24)	-29 (-13)	-24 (-11)	1.5 (37)	1.0 (26)
20.5R25	JCB	Earthmover	L3	203 (92)	110 (50)	95 (43)	1.6 (41)	0.5 (12)
20.5R25	SG Revolution	SE	Solid	4497 (2040)	2456 (1114)	2121 (962)	0.7 (17)	-0.8 (-20)
20.5R25	SG Revolution	S2 C2 DWL	Solid	4771 (2164)	2604 (1181)	2251 (1021)	0.2 (6)	-0.8 (-20)
20.5-25	JCB	Sitemaster (16ply)	L3	220 (100)	121 (55)	104 (47)	0.8 (21)	-0.3 (-7)
20.5R25	Nokian	GRIP TL	L3	-441 (-200)	-240 (-109)	-207 (-94)	0.2 (4)	-0.3 (-7)

LOADER DIMENSIONS 437 ZX

		Direct					Quickhitch			
		General purpose					General purpose			
		Tipped teeth		Reversible toeplate			Tipped teeth		Reversible toeplate	
Bucket mounting										
Bucket type										
Bucket equipment		Tipped teeth		Reversible toeplate			Tipped teeth		Reversible toeplate	
Bucket capacity (SAE heaped 100%)	yd ³ (m ³)	3.01 (2.3)	3.4 (2.6)	3.4 (2.6)	3.14 (2.4)	3.53 (2.7)	3.01 (2.3)	3.4 (2.6)	3.14 (2.4)	3.53 (2.7)
Bucket capacity (struck)	yd ³ (m ³)	2.59 (1.984)	2.97 (2.274)	2.97 (2.274)	2.69 (2.057)	3.07 (2.346)	2.59 (1.984)	2.97 (2.274)	2.69 (2.057)	3.07 (2.346)
Bucket width	ft-in (mm)	9-0 (2740)	9-0 (2740)	9-0 (2740)	8-10 (2700)	8-10 (2700)	9-0 (2740)	9-0 (2740)	8-10 (2700)	8-10 (2700)
Bucket weight	lb (kg)	1635 (1250)	1723 (1317)	1780 (1361)	1651 (1262)	1738 (1329)	1470 (1124)	1568 (1199)	1486 (1136)	1584 (1211)
Maximum material density *	lb/yd ³ (kg/m ³)	3558 (2111)	3118 (1850)	3042 (1805)	3410 (2023)	3004 (1782)	3310 (1964)	2891 (1715)	3174 (1883)	2783 (1651)
Tipping load straight *	lb (kg)	24983 (11332)	24723 (11214)	24235 (10993)	24983 (11332)	24723 (11214)	23349 (10591)	23063 (10461)	23349 (10591)	23063 (10461)
Tipping load full turn *	lb (kg)	21409 (9711)	21213 (9622)	20693 (9386)	21409 (9711)	21213 (9622)	19921 (9036)	19656 (8916)	19921 (9036)	19656 (8916)
Payload *	lb (kg)	10706 (4856)	10606 (4811)	10346 (4693)	10706 (4856)	10606 (4811)	9960 (4518)	9828 (4458)	9960 (4518)	9828 (4458)
Maximum breakout force	lbf (kN)	39566 (176)	36419 (162)	36419 (162)	39566 (176)	36419 (162)	35295 (157)	32372 (144)	35295 (157)	32372 (144)
M Dump angle maximum	degrees	45	45	45	45	45	45	45	45	45
N Roll back angle full height	degrees	52	52	52	52	52	52	52	52	52
O Roll back at carry	degrees	44	44	44	44	44	44	44	44	44
P Roll back at ground level	degrees	35	35	35	35	35	35	35	35	35
Q Load over height	ft-in (mm)	12-4 (3760)	12-4 (3760)	12-4 (3760)	12-4 (3755)	12-4 (3755)	12-4 (3760)	12-4 (3760)	12-4 (3755)	12-4 (3755)
R Dump height (45 deg dump)	ft-in (mm)	9-4 (2841)	9-1 (2776)	9-1 (2776)	9-9 (2982)	9-6 (2900)	9-1 (2756)	8-10 (2691)	9-6 (2897)	9-1 (2765)
S Dig depth	ft-in (mm)	0-5 (131)	0-5 (131)	0-5 (131)	0-4 (105)	0-4 (105)	0-5 (131)	0-5 (131)	0-4 (105)	0-4 (105)
T Reach at dump height	ft-in (mm)	3-9 (1151)	4-0 (1225)	4-0 (1215)	3-5 (1047)	3-4 (1006)	4-1 (1236)	4-3 (1300)	3-9 (1132)	3-7 (1091)
V Pin height	ft-in (mm)	13-2 (4021)	13-2 (4021)	13-2 (4021)	13-2 (4021)	13-2 (4021)	13-2 (4021)	13-2 (4021)	13-2 (4021)	13-2 (4021)
Reach maximum (45 deg dump) horizontal arm	ft-in (mm)	6-3 (1903)	6-5 (1967)	6-5 (1967)	5-11 (1799)	6-1 (1850)	6-6 (1980)	6-8 (2044)	6-2 (1876)	6-4 (1927)
Operating weight (includes 165lbs (75kg) operator and full fuel and DEF tanks)	lb (kg)	34086 (15461)	34236 (15529)	34677 (15729)	34086 (15461)	34236 (15529)	34897 (15829)	35034 (15891)	34897 (15829)	35034 (15891)

*Assumes machine is fitted with Michelin 20.5R25 XHA2 (L3) tires and 5 speed transmission.

ENGINE		427	437
Type		Cummins	
Model		QSB	
Capacity	Liter	6.7	
Aspiration		Turbo Charged	
Cylinders		6	
Max. gross power to SAE J1995/ISO 14396	hp (kW)	179 (133) @ 1,700 RPM	183 (136) @ 2,000 RPM
Net peak power ISO9249	hp (kW)	171 (127) @ 1,700 RPM	175 (130) @ 1,700 RPM
Net peak torque ISO9249	lb-ft (Nm)	612 (829) @ 1,500 RPM	612 (829) @ 1,500 RPM
Rated gross power to SAE J1995/ISO 14396	hp (kW) @ 2,100 RPM	158 (118)	173 (129)
Net power to ISO 9249	hp (kW) @ 2,100 RPM	146 (109)	161 (120)
Max torque	lb-ft (Nm) @ 1,500 RPM	620 (841)	
Valves per cylinder		4	
Air cleaner		Cyclonic pre filter with engine fan scavenge system	
Fan drive type		Hydraulically driven cooling fan	
Emissions		EU Stage IV, US EPA Tier 4F	

TRANSMISSION								
	427		427		437		437	
	4 speed non-lock up converter		5 speed with lock up converter (optional)		4 speed non-lock up converter		5 speed with lock up converter (optional)	
Type	ZF							
Model	4WG160		5WG160		4WG190		5WG190	
	Forward	Reverse	Forward	Reverse	Forward	Reverse	Forward	Reverse
1 mph (kph)	4.08 (6.6)	4.31 (6.9)	4.23 (6.8)	4.47 (7.2)	4.25 (6.8)	4.48 (7.2)	4.36 (7.0)	4.60 (7.4)
2 mph (kph)	8.13 (13.1)	8.56 (13.8)	7.74 (12.5)	8.15 (13.1)	7.94 (12.8)	8.35 (13.4)	7.92 (12.7)	8.35 (13.4)
3 mph (kph)	14.60 (23.5)	15.32 (24.7)	11.90 (19.2)	18.71 (30.1)	15.26 (24.6)	15.98 (25.7)	12.14 (19.5)	19.75 (31.8)
4 mph (kph)	23.92 (38.5)		17.77 (28.6)		23.61 (38.0)		18.76 (30.2)	
5 mph (kph)			24.85 (40.0)				24.85 (40.0)	

Please note the above data is based on Michelin 20.5R25 XHA2 (L3) tires, figures may vary depending on tires fitted.

AXLES		427	
Model		427	
Type		Standard	Heavy duty
Make and model		ZF MT-L 3075 II (front), ZF MT-L 3075 II (rear)	ZF MT-L 3085 II (front), ZF MT-L 3075 II (rear)
Overall axle ratio		21.53 : 1	
Rear axle oscillation		+/- 10.5 Degrees	
Model		437	
Type		Heavy duty	
Make and model		ZF MT-L 3085 II (front), ZF MT-L 3075 II (rear)	
Overall axle ratio		21.53 : 1	
Rear axle oscillation		+/- 10.5 Degrees	

All available with open differential, Limited slip differential, Open differential with auto-locking front.

ELECTRICAL SYSTEM		
System voltage	Volt	24
Alternator output	Amp hour	120
Battery capacity	Amp hour	110

HYDRAULICS		
	427	437
Pump type	Variable displacement	
Pump 1 max. flow	gal/min (l/min)	33.29 (126)
Pump 1 max. pressure	psi (bar)	3626 (250)
Pump 2 max. flow	gal/min (l/min)	33.29 (126)
Pump 2 max. pressure	psi (bar)	2321 (160)
Hydraulic cycle times at full engine revs		
Arms raise (full bucket)	Seconds	5.08
Bucket dump (full bucket)	Seconds	1.41
Arms lower (empty bucket)	Seconds	3.3
Total cycle	Seconds	9.79

CAB	In-cab noise level – 68dB(A).
STEERING	Hydraulic power steering.
BRAKES	Hydraulic power braking on all wheels. In-board mounted, oil immersed, multi-plate disc brakes. Parking brake, electro-hydraulic disc type operating on transmission output shaft.

SERVICE FILL CAPACITIES		
	427	437
Hydraulic system	gallons (liter)	55.5 (210)
Fuel tank	gallons (liter)	76.6 (290)
DEF Tank	gallons (liter)	10.6 (40)

LOADER DIMENSIONS WITH FORKS

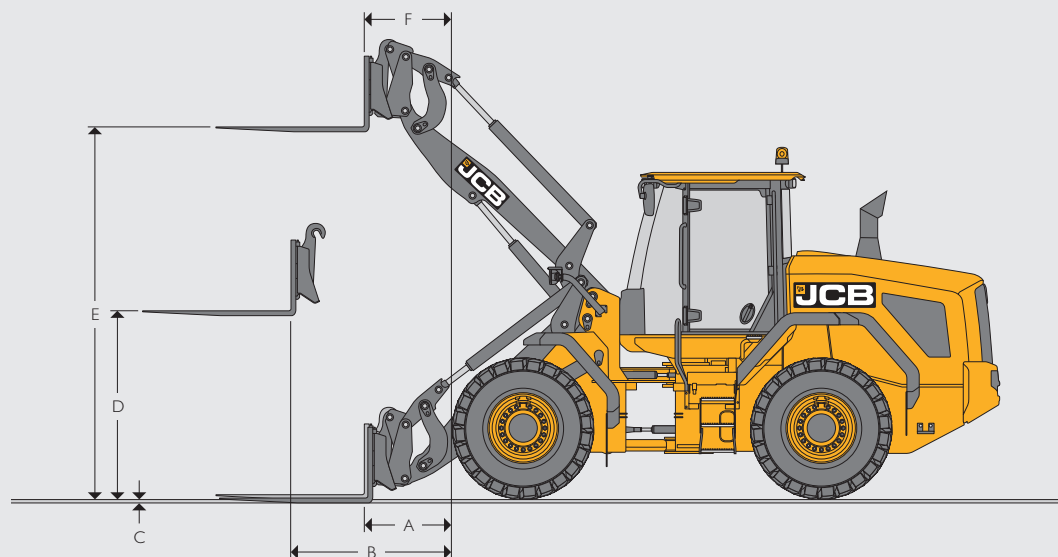

LOADER DIMENSIONS WITH FORKS

		427 HT		427 HT HL		437 HT		437 HT HL		437 HT SHL	427 ZX	437 ZX
		Parallel	Non parallel	Parallel	Non parallel	Parallel	Non parallel	Parallel	Non parallel	Non parallel	Parallel	Parallel
Fork carriage width	ft-in (mm)	4-11 (1500)	4-11 (1500)	4-11 (1500)	4-11 (1500)	4-11 (1500)	4-11 (1500)	4-11 (1500)	4-11 (1500)	4-11 (1500)	4-11 (1500)	4-11 (1500)
Length of tines	ft-in (mm)	4-0 (1220)	4-0 (1220)	4-0 (1220)	4-0 (1220)	4-0 (1220)	4-0 (1220)	4-0 (1220)	4-0 (1220)	4-0 (1220)	4-0 (1220)	4-0 (1220)
A Reach at ground level	ft-in (mm)	2-6 (769)	2-6 (769)	4-1 (1238)	4-1 (1238)	2-11 (882)	2-11 (882)	5-0 (1518)	5-0 (1518)	6-10 (2079)	2-6 (769)	2-6 (769)
B Reach at arms horizontal	ft-in (mm)	5-1 (1546)	5-1 (1546)	6-3 (1895)	6-3 (1895)	5-4 (1636)	5-4 (1636)	7-0 (2126)	7-0 (2126)	8-6 (2596)	5-1 (1546)	5-1 (1546)
C Top of tine above ground with arms down	ft-in (mm)	-1-10 (-52)	-1-11 (-25)	0-0 (11)	0-1 (38)	0-0 (8)	0-1 (16)	0-0 (3)	0-0 (11)	0-0 (-11)	-1-10 (-52)	-1-10 (-52)
D Arms, horizontal height	ft-in (mm)	6-3 (1906)	6-2 (1867)	6-3 (1906)	6-2 (1867)	6-5 (1946)	6-4 (1936)	6-5 (1946)	6-4 (1936)	6-4 (1936)	6-3 (1906)	6-3 (1906)
E Arms, maximum height	ft-in (mm)	12-2 (3718)	12-1 (3695)	13-7 (4148)	13-6 (4125)	12-7 (3828)	12-6 (3818)	14-8 (4482)	14-8 (4472)	16-6 (5035)	12-2 (3718)	12-2 (3718)
F Reach at maximum height	ft-in (mm)	2-8 (802)	2-8 (824)	2-9 (848)	2-10 (875)	2-10 (873)	2-11 (882)	2-10 (875)	2-11 (889)	3-0 (907)	2-8 (802)	2-8 (802)
Tipping load straight	lb (kg)	22540 (10224)	24207 (10980)	17514 (7944)	18517 (8399)	21140 (9589)	22463 (10189)	17808 (8077.58)	18755 (8507)	10326 (4684)	19339 (8772)	19339 (8772)
Tipping load full turn (40°)	lb (kg)	21136 (9587)	20889 (9475)	15106 (6852)	15977 (7247)	18078 (8200)	19215 (8716)	15189 (6889.66)	16001 (7258)	12033 (5458)	16645 (7550)	16645 (7550)
Payload*	lb (kg)	11023 (5000)	11023 (5000)	11023 (5000)	11023 (5000)	11023 (5000)	11023 (5000)	11023 (5000)	11023 (5000)	9628 (4367)	13316 (6040)	13316 (6040)
Attachment weight	lb (kg)	946 (429)	946 (429)	946 (429)	946 (429)	946 (429)	946 (429)	946 (429)	946 (429)	946 (429)	946 (429)	946 (429)
Operating weight (includes 75kg operator and full fuel and DEF tanks)	lb (kg)	28720 (13027)	28720 (13027)	29183 (13237)	29183 (13237)	32481 (14733)	32481 (14733)	33404 (15152)	33404 (15152)	34397 (15602)	30128 (13666)	30128 (13666)

* At the center of gravity distance 23.6" (600mm). Based on 80% of FTTL as defined in ISO 14397-1:2007. Assume Michelin 20.5R25 XHA2 (L3) and 5 speed transmission.

MATERIAL DENSITY

Material	Loose density		Fill factor
	lb/yd ³	kg/m ³	
Snow (fresh)	337	200	110
Peat (dry)	674	400	100
Sugar beet	893	530	100
Coke (loose)	961	570	85
Barley	1011	600	85
Petroleum coke	1146	680	85
Wheat	1230	730	85
Coal bituminous	1289	765	100
Fertilizer (mixed)	1736	1030	85
Coal anthracite	1763	1046	100
Earth (dry) (loose)	1938	1150	100
Nitrate fertilizer	2107	1250	85
Sodium chloride (dry) (salt)	2191	1300	85
Cement portland	2427	1440	100
Limestone (crushed)	2579	1530	100
Sand (dry)	2613	1550	100
Asphalt	2697	1600	100
Gravel (dry)	2781	1650	85
Clay (wet)	2832	1680	110
Sand (wet)	3186	1890	110
Fire clay	3506	2080	100
Copper (concentrate)	3877	2300	85
Slate	4720	2800	100
Magnetite	5401	3204	100

BUCKET CAPACITIES – 427

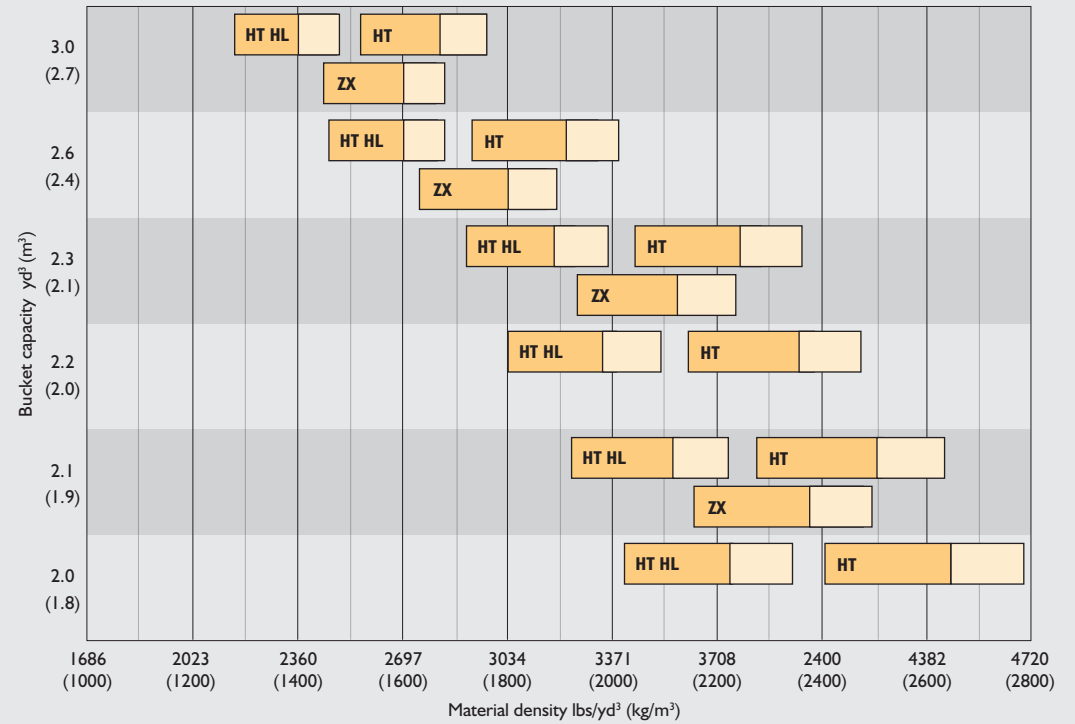

BUCKET CAPACITIES – 437

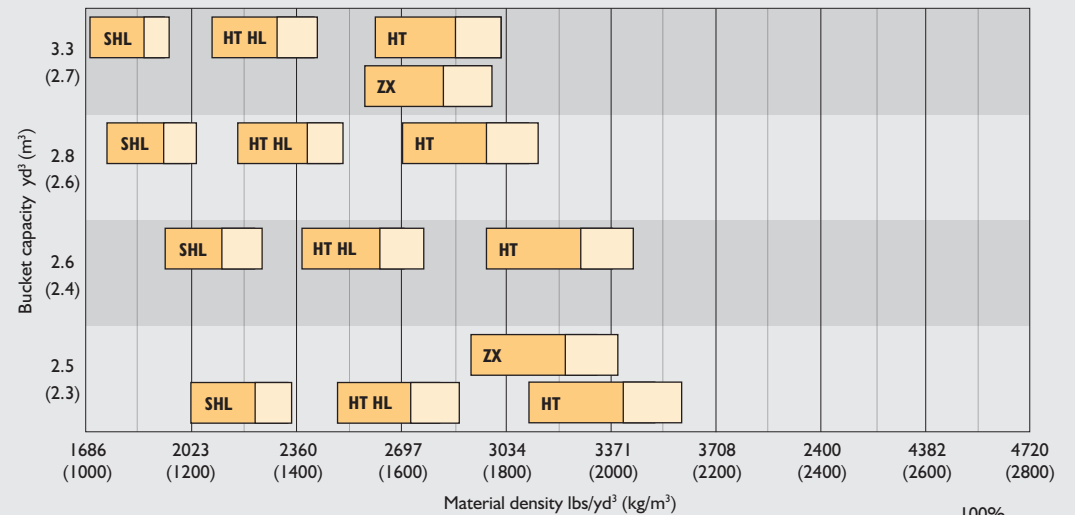

HT = Standard height arm HL = High Lift arm SHL = Super high lift arm ZX = Z bar

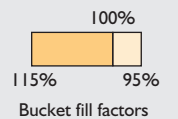

EQUIPMENT

SERVICE AND MAINTENANCE

5 year LiveLink telematics	•
Engine oil remote drain and fill	•
Grouped pressure test points	•
Lockable tool box	•
Lubrication points accessible from ground level	•

ENGINE

Air cleaner – cyclonic pre filter with engine fan scavenge system	•
Automatically reversing cooling fan	+
Crankcase breather oil trap	•
DEF fluid	•
Electrical opening rear engine hood	•
Epoxy coated radiator / coolers	+
Fixed mounted fan	•
Fuel filter	•
Fuel pre-filter with water trap	•
Hydraulically driven cooling fan	•
Manual override rear engine hood opening	•
-4°F (-20°C) cold start	•
SCR engine emission control	•
Swing out fan	+
Waste gated turbo	•
Widecore cooling pack	•
Engine block heater (110V)	•
Auxiliary fuel tank +29 gal (110 liter) (427 AGRI only)	+

ELECTRICAL

120 amp alternator	•
Amber rotating beacon	•
Electrical adjustable mirrors	•
Heated mirrors	•
External battery isolator	•
Fold down beacon arm	•
Green seat belt beacon	+
Halogen front and rear working lights	•
Hazard warning lights	•
Integrated rear view camera	+
LED front and rear working lights	+
LED 360 degree working lights	+
Number plate light kit	+
Parking lights	•
Radio wiring and speakers	•
Rear fog light	•
Reverse alarm and light	•
Smart reverse alarm and light	+
White noise reverse alarm and light	+
Work lights in rear grill	•
Engine hood operation alarm	•

ELECTRICAL (CONTINUED)

Blue LED reverse lights	+
-------------------------	---

DRIVE TRAIN

4 speed transmission	•
5 speed transmission with lock-up torque converter	+
6 speed transmission with lock-up torque converter (427 AGRI model only)	+
Epicyclical wheel hub reduction	•
Fixed front axle	•
Gear kick down on loader control lever	•
Indicator glass for transmission oil level	•
Limited slip differentials front and rear	•
Loader lever direction control	•
Neutral start	•
Standard differential	+
Standard differential with automatic locking - 100% (front axle only)	+
Oscillating rear axle	•
Power-inch intelligent clutch cut off on footbrake (selectable)	•
Heavy-duty front axle (427 only)	+
Sintered brake pads	+
Selectable automatic power shift	•
Speed limiter 20km/h	+
Steering column single lever shift control (direction and gear)	•
Transmission cooler bypass	+

BRAKE SYSTEM

Multi-plate wet disc brakes	•
Sintered brake pads	•
Dual circuit hydraulic power	•
Wheel speed braking	•
Parking disc brake on transmission output shaft	•
Electrical hydraulic park brake actuation	•
Accumulator back-up for electric park brake	•

OPERATOR STATION

Fully glazed cab	•
Front low window guards	+
Air conditioning	•
Climate control	+
Single lever joystick	•
Multi-lever hydraulic controls	+
Proportional electro hydraulic auxiliary control	+
Electronically Adjustable hydraulic auxiliary flow rate	+
Air suspension cloth seat	•
Deluxe heated air suspension cloth seat	+
Super deluxe heated and cooled air suspension half leather seat	+
Front roller sun visor	•
Rear roller sun visor	+
Cab air intake filter	•

OPERATOR STATION (CONTINUED)

Carbon cab air intake filter	+
12V in cab power socket	•
2 x 12V in cab power socket	+
24V in cab power socket	+
Reversing camera (color)	+
Fold away adjustable steering column	•
ROPS/FOPS safety structure	•
Interior light	•
Front primary display screen	•
Secondary A post display screen, rotary control menu interface	+
A post mounted membrane switches	•
Variable fan speed control on climate control system	+
2 inch seat belt	•
3 inch seat belt	+
Two speed intermittent front window wipe/wash and self-park	•
Single speed rear window wipe/wash and self-park	•
3 speed heater/demisting	•
Variable speed heater	•
LH and RH sliding opening windows	•
Floor mat	•
Cup holder	•
Steering wheel spinner knob	•
Internal rear view mirror	•
Tinted cab glass	•
Multi-media port (USB and audio Jack)	+
Operator storage	•
Laminated window	•
Heated rear window	•
Loader control isolator	•
Horn	•
Adjustable armrest	•
Removable storage rubber mats	•
Convex mirror kit (1 on each side)	+
Adjustable seat mounted controls	•
Electronic adjustment of SRS (Smooth Ride System) cut in speed	+
Electronic adjustment of reverse fan interval	+

FRONT PRIMARY DISPLAY

Warning lights	
Direction indicators	•
Master warning	•
High coolant temperature	•
Battery charging condition	•
Low fuel level	•
Engine oil pressure	•
Hazard lamps	•
Park brake state	•

EQUIPMENT (CONTINUED)

FRONT PRIMARY DISPLAY

Warning lights (continued)

Road lights	•
Main beam lights	•
Rear fog lights	•
Engine pre-heat	•
Brake system pressure	•
Differential lock	•
Low steering pressure	•

Buzzer alerts

Engine air filter blocked	•
Diesel exhaust fluid (DEF)	•
Torque reduction in case of malfunction	•
Amber warning lamp	•
Stop engine	•

Gauge display

Engine speed	•
Coolant temperature	•
Fuel level	•

LCD screen display

Current gear	•
Stop engine	•
Torque reduction in case of malfunction	•
Amber warning lamp	•
Diesel exhaust fluid (DEF)	•
Engine air filter blocked	•
Secondary steer system pressure	•
Torque lockup	•
Steer mode	•
Ground speed	•
Engine speed (numeric display)	•
Clock	•
Hydraulic state	•
Smoothride system (SRS)	+

Beacon	•
Front work lamps	•
Rear work lamps	•
Heated rear screen	•
Transmission sump temperature	•

Data screens

DEF level	•
Hydraulic oil temperature	•
Torque convertor temperature	•
Volume of fuel remaining	•
Total fuel used (resettable)	•
Instantaneous fuel use	•
Average fuel use (resettable)	•
Current date	•
Machine hours	•

FRONT PRIMARY DISPLAY (CONTINUED)

Data screens (continued)

Trip distance (resettable)	•
Hours to service	•
Daily checks	
Engine oil level	•
DEF level	•

RIGHT HAND SECONDARY DISPLAY (OPTIONAL)

Clock	•
Climate control	•
Fan speed	•
In cab temperature set	•
Machine hours	•
Rear view camera with full-screen reverse mode	•
Fuel use	•
Adjustable smooth ride engagement speed	+
Adjustable reverse fan intervals	+
Adjustable auxiliary flow	+
Adjustable constant flow	+
Time and date	•
Hydraulic oil temperature	•
Transmission oil temperature	•

Machine settings screen

Coolant temperature	•
Engine oil pressure	•
Air filter	•
Transmission sump temperature	•
Transmission torque convertor temperature	•
Hydraulic oil temperature	•
Park brake pressure	•
Battery voltage	•
Help display	•
On-screen handbook	•

HYDRAULIC SYSTEM

Smoothride system (SRS)	+
Hydraulic quick hitch with in cab isolation	+
Auxiliary ARV kit	+
Auxiliary hydraulic service	+
Twin auxiliary hydraulic service	+
Twin piston pumps with priority steer	•
Emergency steer back-up	•
JCB biodegradable hydraulic oil	+
Electronic hydraulic isolation	•
Automatic boom kick-out. Detent	•
Automatic bucket positioner	•

HYDRAULIC SYSTEM (CONTINUED)

Front loader float	•
Constant auxiliary flow	•
Indicator glass for hydraulic oil level	•
Hydraulic oil cooler	•

EXTERNAL EQUIPMENT

Front and rear fenders	•
Full rear fenders	+
Front adjustable mud flaps	•
Front wheel spray guards	•
Full tire width coverage fenders	•
Rear object detection radar system with in cab display	+
Automatic greasing system	+
Grease gun and cartridge	+
One piece electrical opening engine hood	•
Mesh air intake screens	•
Flexible bottom step	•
Full width rear counterweight	•
Recovery hitch	•
Lifting / tie down lugs	•
Rockinger rear towing hitch with hydraulic braking system (427 AGRI only)	+

PROTECTIVE EQUIPMENT

Front cab screen guards	+
Wastemaster package: includes front and rear light guards, front screen guard, front and rear belly guards, rear light guards, widcore radiator, Wastemaster decal.	+
Heavy-duty rear grill guard (available black or white)	+
Safety strut loader arm	•
Light guards	+
Front belly guard kits	+
Rear belly guard kits	+
Articulation joint safety strut	•

OTHER EQUIPMENT

HT High Lift loader end (427 and 437)	+
HT Super High Lift loader end (437 only)	+
Parallel lift HT loader arms	+

STANDARD •

OPTIONAL +





Oetgen 313-7113

**OETGEN'S
MATERIAL HAULING**
Blainville, Ga
748-5031

MASONRY SAND
PINE BARK
FILL DIRT
TOP SOIL

MOBILE 313

5000



ONE COMPANY, OVER 300 MACHINES.

Your nearest JCB Dealer

JCB North American – Headquarters

2000 Bamford Blvd., Savannah, Georgia, 31322 Tel: (912) 447-2000

Download the very latest information on this product range at www.jcbna.com

JCB inc. All rights reserved. No part of this publication may be reproduced, stored in a retrieval system, or transmitted in any form or by any other means, electronic, mechanical, photocopying or otherwise, without prior permission from JCB inc. All references in this publication to operating weights, sizes, capacities and other performance measurements are provided for guidance only and may vary dependant upon the exact specification of machine. They should not therefore be relied upon in relation to suitability for a particular application. Guidance and advice should always be sought from your JCB Dealer. JCB reserves the right to change specifications without notice. Illustrations and specifications shown may include optional equipment and accessories. The JCB logo is a registered trademark of J.C. Bamford Excavators Ltd.

