



<u>SwapLoader SL 2418</u>	<u>\$51,350.00</u>
<u>SwapLoader SL 240</u>	<u>\$52,300.00</u>
<u>SwapLoader SL 222</u>	<u>\$52,153.00</u>
<u>SwapLoader SL 220</u>	<u>\$52,282.00</u>

Pump/PTO

Mounting

Fenders

Hydraulic Oil

Finish Coat of Paint

Heavy Duty Bumper with LED Recessed Lights

Air Controls and Tower in Cab

Huck Bolts Used on Mounting

Hoist In-Bound Freight

Delivery in NC





An EFCO Company

SWAPLOADER[®]

"Hooked on Quality"

U.S.A. LTD.



ALL-MODEL SPECIFICATIONS



ALL-MODEL SPECIFICATIONS

MODEL		SL-75	SL-105	SL-160	SL-212	SL-214	SL-220	SL-222	SL-240
MODEL DESCRIPTION	DUMP CAPACITY (INCLUDING CONTAINER)	7,500 lb	10,500 lb	16,000 lb	20,000 lb	20,000 lb	22,000 lb	22,000 lb	24,000 lb
	DUMP ANGLE	56°	58°	56°	58°	57°	53°	53°	53°
	LIFT CAPACITY (INCLUDING CONTAINER)	7,500 lb	10,500 lb	16,000 lb	20,000 lb	20,000 lb	22,000 lb	22,000 lb	24,000 lb
	HOIST WEIGHT	FIXED 1,250 lb ADJ. N/A	1,680 lb N/A	2,325 lb 2,467 lb	2,520 lb 2,640 lb	2,720 lb 2,860 lb	4,100 lb 4,330 lb	4,050 lb 4,280 lb	3,900 lb 4,200 lb
GENERAL DIMENSIONS (SEE DIAGRAM)	HOOK TO REAR ROLLER (DIM. A)	114.38"	116.00"	139.63"	138.00"	153.63"	193.81"	179.81"	159.81"
	HOOK HEIGHT (DIM. B)	FIXED 35.63" ADJ. N/A	35.63" N/A	35.63" 35.63" / 53.88"	35.63" 35.63" / 53.88"	35.63" 35.63" / 53.88"	53.88" 53.88" / 61.75"	53.88" 53.88" / 61.75"	53.88" 53.88" / 61.75"
	HOIST HEIGHT (DIM. C)	5.25"	5.5"	7.5"	7.5"	7.5"	9"	9"	9"
	HOIST CG (DIM. D)	59.7"	58.1"	70.65"	64.0"	80.3"	97.8"	95.2"	88.0"
	OPTIMUM BODY LENGTHS (DIM. E)	10' - 12'	10' - 12'	12' - 14'	12' - 14'	14' - 16'	18' - 20' 1	16' - 18'	14' - 16'
	POTENTIAL BODY LENGTHS 1	9' - 13'	10' - 13'	10' - 15'	10' - 16'	12' - 18'	14' - 22'	14' - 20'	12' - 18'
	BODY LONGSILL WIDTH 2	41.63" / 39.00"	41.63"	41.63" / 40.50"	41.63" / 40.50"	41.63" / 40.50"	41.63" / 40.50"	41.63" / 40.50"	41.63" / 40.50"
HYDRAULIC SYSTEMS	HYDRAULIC PUMP TYPE (CID)	Gear (0.85)	Gear (1.86)	Gear (2.96)	Gear (2.96)	Gear (2.96)	Gear (4.46)	Gear (4.46)	Gear (4.46)
	FLOW @ PUMP RPM 3	3.1 GPM @ 1,000 RPM	7.2 GPM @ 1,000 RPM	11.4 GPM @ 1,000 RPM	11.4 GPM @ 1,000 RPM	11.4 GPM @ 1,000 RPM	17.4 GPM @ 1,000 RPM	17.4 GPM @ 1,000 RPM	17.4 GPM @ 1,000 RPM
	RELIEF PRESSURE	3,250 PSI	3,250 PSI	3,250 PSI	3,250 PSI	3,250 PSI	2,800 PSI	2,800 PSI	2,800 PSI
	HYDRAULIC RESERVOIR	7 gal	15 gal	15 gal	15 gal	15 gal	25 gal	25 gal	25 gal
LIFT CYLINDER	TYPE	ALL MODELS INCORPORATE DOUBLE ACTING CYLINDERS WITH DUAL BUILT-IN COUNTERBALANCE VALVE.							
	QUANTITY	1	2	2	2	2	2	2	2
	BORE	Ø 4"	Ø 4"	Ø 5"	Ø 5.5"	Ø 5.5"	Ø 6"	Ø 6"	Ø 6"
	STROKE	38"	38"	43"	46"	54"	54"	54"	54"
JIB CYLINDER	TYPE	5	MODELS INCORPORATE A SINGLE, DOUBLE ACTING CYLINDER WITH A SINGLE BUILT-IN COUNTERBALANCE VALVE.						
	QUANTITY	2	1	1	1	1	1	1	1
	BORE	Ø 1.5"	Ø 2.5"	Ø 3"	Ø 3"	Ø 3"	Ø 3.5"	Ø 3.5"	Ø 3.5"
	STROKE	20"	24"	32"	32"	36"	48"	34"	30"
TRUCK SPECS (RECOMMENDED)	GVW RANGE 6	14,000 lb - 16,000 lb	16,000 lb - 19,000 lb	18,000 lb - 26,000 lb	25,000 lb - 35,000 lb	25,000 lb - 35,000 lb	25,000 lb - 35,000 lb	25,000 lb - 35,000 lb	25,000 lb - 35,000 lb
	CAB-AXLE DIM. (SINGLE AXLE) 7	84" - 96"	84" - 96"	108" - 120"	108" - 120"	120" - 138"	156" - 174"	142" - 160"	130" - 144"
	CAB-TRUNNION DIM. (TANDEM AXLE) 7	N/A	N/A	N/A	N/A	N/A	150" - 162"	130" - 142"	120" - 132"
	CLEAR FRAME RAIL 8	126"	130"	153"	156"	172"	216"	202"	184"
	FRAME HEIGHT	up to 38"	up to 40"	up to 40"	up to 40"	up to 40"	up to 43"	up to 43"	up to 43"
PTO SPECS (RECOMMENDED)	PUMP MOUNT 9	Direct Mount SAE A, 2 Bolt	Direct Mount SAE B, 2 Bolt	Direct Mount SAE B, 4 Bolt	Direct Mount SAE B, 4 Bolt	Direct Mount SAE B, 4 Bolt	Direct Mount SAE B, 4 Bolt	Direct Mount SAE B, 4 Bolt	Direct Mount SAE B, 4 Bolt
	TORQUE REQUIRED	40 ft-lbf	80 ft-lbf	125 ft-lbf	125 ft-lbf	125 ft-lbf	200 ft-lbf	200 ft-lbf	200 ft-lbf

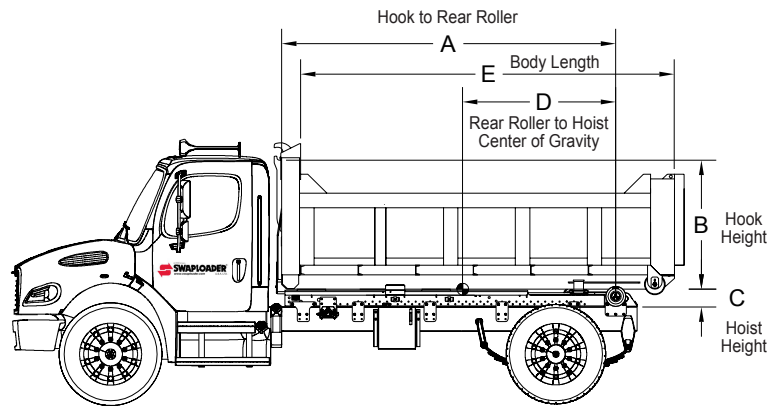

SL-2418	SL-330	SL-400	SL-406	SL-412	SL-518	SL-520	SL-650
24,000 lb	33,000 lb	40,000 lb	40,000 lb	40,000 lb	54,000 lb	50,000 lb	65,000 lb
57°	58°	58°	55°	60°	57°	57°	54°
24,000 lb	33,000 lb	40,000 lb	40,000 lb	40,000 lb	53,000 lb	50,000 lb	65,000 lb
3,040 lb	5,170 lb	5,290 lb	5,920 lb	4,780 lb	6,600 lb	7,055 lb	8,050 lb
N/A	5,330 lb	5,450 lb	6,085 lb	4,930 lb	6,840 lb	7,310 lb	N/A
118.00"	167.50"	167.50"	209.75"	143.50"	201.00"	222.75"	226.50"
53.88"	61.75"	61.75"	61.75"	61.75"	61.75"	61.75"	61.75"
N/A	61.75" / 53.88"	61.75" / 53.88"	61.75" / 53.88"	61.75" / 53.88"	61.75" / 53.88"	61.75" / 53.88"	N/A
9"	11"	11"	11"	11"	12"	12.5"	13"
63.8"	88.8"	88.8"	114.0"	75.6"	108.0"	118.0"	125.0"
10' - 12'	14' - 16'	14' - 16'	18' - 20'	12' - 14'	18' - 20' 1	20' - 22'	20' - 22'
10' - 13'	12' - 18'	12' - 18'	16' - 22'	12' - 15'	15' - 22'	17' - 24'	17' - 24'
41.63" / 40.50"	40.50" / 41.63"	40.50" / 41.63"	40.50" / 41.63"	40.50" / 41.63"	40.50" / 41.63"	40.50" / 41.63"	40.50" / 41.63"
Gear (4.46)	Gear (3.83)	Gear (3.83)	Gear (3.83)	Gear (3.83)	Gear (4.46)	Gear (4.46)	Gear (4.46)
17.4 GPM @ 1,000 RPM	22.3 GPM @ 1,500 RPM	22.3 GPM @ 1,500 RPM	22.3 GPM @ 1,500 RPM	22.3 GPM @ 1,500 RPM	26.0 GPM @ 1,500 RPM	26.0 GPM @ 1,500 RPM	26.0 GPM @ 1,500 RPM
2,800 PSI	3,500 PSI	3,500 PSI	3,500 PSI	3,500 PSI	3,500 PSI	3,500 PSI	3,500 PSI
25 gal	30 gal	30 gal	30 gal	30 gal	30 gal	30 gal	30 gal
ALL MODELS INCORPORATE DOUBLE ACTING CYLINDERS WITH DUAL BUILT-IN COUNTERBALANCE VALVE.							
2 4	2 4	2 4	2	2 4	2	2	2
Ø 5.5"	Ø 5.5"	Ø 6"	Ø 6.5"	Ø 6"	Ø 7"	Ø 7"	Ø 7.5"
39"	60"	60"	74"	56"	74"	82"	82"
MODELS INCORPORATE A SINGLE, DOUBLE ACTING CYLINDER WITH A SINGLE BUILT-IN COUNTERBALANCE VALVE.							
1 4	1 4	1 4	1	1 4	1	1	1
Ø 4"	Ø 4"	Ø 4"	Ø 4"	Ø 4"	Ø 4.5"	Ø 4.5"	Ø 4.5"
24"	38"	38"	52"	30"	48"	52"	52"
25,000 lb - 35,000 lb	33,000 lb or greater	45,000 lb or greater	45,000 lb or greater	45,000 lb or greater	50,000 lb or greater	50,000 lb or greater	55,000 lb or greater
84" to 96"	142" - 156"	N/A	N/A	N/A	N/A	N/A	N/A
N/A	130" - 138"	130" - 138"	174" - 180"	102" - 114"	165" - 174"	176" - 190"	172" - 190"
134"	191"	191"	232"	169"	225"	245"	249"
up to 43"	up to 43"	up to 43"	up to 45"	up to 45"	up to 45"	up to 45"	up to 45"
Direct Mount SAE B, 4 Bolt	Direct Mount SAE B, 4 Bolt	Direct Mount SAE B, 4 Bolt	Direct Mount SAE B, 4 Bolt	Direct Mount SAE B, 4 Bolt	Direct Mount SAE B, 4 Bolt	Direct Mount SAE B, 4 Bolt	Direct Mount SAE B, 4 Bolt
200 ft-lbf	200 ft-lbf	200 ft-lbf	200 ft-lbf	200 ft-lbf	230 ft-lbf	230 ft-lbf	230 ft-lbf

- 1 Hoist potential body length range may not conform with I.C.C. bumper regulations or may not achieve maximum dump angle depending on truck chassis height. Shorter bodies available on some models with use of a shelf assembly or CVS system. Contact your SwapLoader distributor for more information.
- 2 Maximum outside to outside long sill width.
- 3 Pump RPM and Flow are dependent on engine RPM and PTO ratio.
- 4 Polished nitrided cylinder rod.
- 5 Counterbalance valve manifold.
- 6 A lower GVW will limit your payload potential.
- 7 Optimum CA/CT dimension will be influenced by type of loads carried and turning radius requirements.
- 8 Clear frame dimension given is the overall length of hoist plus 5" for cab clearance and rear light bar mounting. Additional frame length may be necessary for other accessories such as cab guard, tarper, exhaust system, etc.
- 9 PTO/Pump rotation as determined by transmission.

ONE TRUCK UNLIMITED POSSIBILITIES



- ▶ **QUALITY**
- ▶ **INTEGRITY**
- ▶ **INNOVATION**
- ▶ **SUPER SERVICE**



WHAT COULD YOU DO WITH A **SWAPLOADER** TODAY?



HOOKED ON **QUALITY**





An EFCO Company

SWAPLOADER[®]

"Hooked on Quality" U.S.A. LTD.



 YouTube www.youtube.com/swaploader

MADE IN USA 



1800 NE Broadway Ave. Des Moines, IA 50313

web: swaploader.com

email: sales@swaploader.net

toll free: 888.767.8000

phone: 515.266.3042