



TECHNICAL DATA

MASSES

Max. operating mass	3,900 lbs
Operating mass (incl. ROPS)	3,700 lbs
Module mass (front/rear)	1,700 lbs/2,000 lbs

COMPACTION

Centrifugal force	3,821.94 lbs
Nominal amplitude	0.014 in
Static linear load (front/rear)	44 /50 lbs/in
Vibration frequency	4,200 vpm
Water tank	50 gal

PROPULSION

Speed range	0-9 km/h
Vertical oscillation	±13°

ENGINE

Manufacturer/Model	Kubota D1105-E4B T4f/V
Type	Water cooled diesel
Rated power, SAE J1995	24 hp @ 2,800 rpm
Fuel tank capacity	6 gal

HYDRAULIC SYSTEM

Driving	Axial piston pump with variable displacement and servo. 2 radial piston motors with constant displacement.
Vibration	Gear pump/motors with constant displacement.
Steering	Gear pump with constant displacem.
Service brake	Hydrostatic in forward and reverse lever.
Parking/ Emergency brake	Failsafe brake in both drums.

Find us locally at www.dynapac.com

We reserve the right to change specifications without notice. Photos and illustrations do not always show standard versions of machines. The above information is a general description only, all information's are supplied without liability.

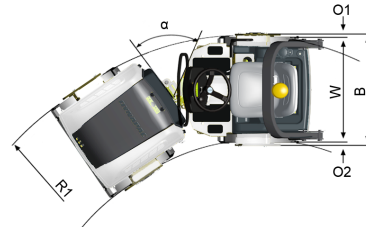
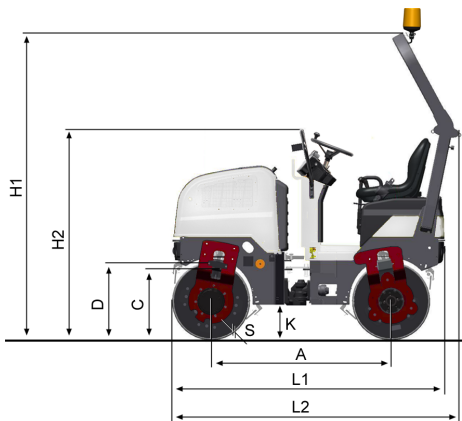

TECHNICAL DATA

DIMENSIONS

A. Wheelbase	53 in
B. Width	42 in
C. Curb clearance	18 in
D. Drum diameter	23 in
H2. Height, w/o ROPS/cab	62 in
K. Ground clearance	10 in
L1. Length	80 in
L2. Length (ROPS)	82 in
O1. Overhang, right	1,4 in
O2. Overhang, left	1,4 in
R1. Turning radius, outside	9,3 ft
S. Drum shell thickness	0,51 in
W. Working width	39 in
α. Steering angle	±34°

STANDARD EQUIPMENT

- Auto Vibration Ctrl (AVC)
- Auto Water Ctrl (AWC)
- Back up alarm, Central lifting eye
- Cup/Can holder, Emergency stop
- Foldable ROPS, Fuel gauge
- Horn, Hourmeter
- Hydraulic pressure checkpoints
- Ignition key, Interlock brake
- Pressurized sprinkler system
- Rubber mounted operator's platform
- Seat belt, Sprinkler timer
- Towing eyelet front/rear
- Vibration both drums
- Warning lights;
- Brake -Charging -Engine oil pressure/ water temp -Low fuel

OPTIONAL EQUIPMENT

- Biodegradable hydraulic fluid
- Cert. fire protection (SBF 127)
- Decal risk location (GOST)
- Fire extinguisher, Hearing protectors
- Licence plate light
- Rear view mirror (traffic view)
- Service kit 50/500/1000 h
- Side direction lights (driving lights required)
- Slow moving vehicle sign
- Special color (one or two)
- Tool set, Water tank cover (lockable)