



TECHNICAL DATA

MASSES

Max. operating mass	25,800 lbs
Operating mass (incl. ROPS)	22,700 lbs
Module mass (front/rear)	13,000 lbs/9,700 lbs

COMPACTION

Wheel load	2,425 lbs/wheel
Centrifugal force (high/low amplitude)	32,370/20,910 lbs
Nominal amplitude (high/low)	0.031/0.012 in
Static linear load	170 lbs/in
Vibration frequency (high/low amplitude)	3,060/4,020 vpm
Water tank	224 gal
Emulsion tank	53 gal
Water tank (front drum steering)	174 gal

COMPACTION (CE)

Centrifugal force (high/low amplitude)	106 kN/68 kN
Vibration frequency (high/low amplitude)	44 Hz/58 Hz

PROPULSION

Speed range	0-7.5 mph
Vertical oscillation	±7°
Max. theoretical gradeability	35 %

ENGINE

Manufacturer/Model	Cummins F3.8 V
Type	Water cooled turbo diesel
Rated power, SAE J1995	135 hp @ 2,200 rpm
Fuel tank capacity	48 gal
DEF tank capacity	4 gal

ENGINE

Manufacturer/Model	Cummins QSF3.8 IV/T4f
Type	Water cooled turbo diesel
Rated power, SAE J1995	97 kW (130 hp) @ 2200 rpm
Fuel tank capacity	48 gal
DEF tank capacity	3.96 gal

ENGINE

Manufacturer/Model	Cummins QSF 3.8 IIIA/T3
Type	Water cooled turbo diesel
Rated power, SAE J1995	104 kW (140 hp) @ 2200 rpm

HYDRAULIC SYSTEM

Driving	Axial piston pump with variable displacement. Radial piston motors (3) with variable displacement.
Vibration	Axial piston pump with variable displacement. Axial piston motor with constant displacement.
Steering	Gear pump with constant displacem.
Service brake	Hydrostatic in forward and reverse lever.
Parking/Emergency brake	Failsafe multidisc brake in drum and wheel motors.

Find us locally at www.dynapac.com

We reserve the right to change specifications without notice. Photos and illustrations do not always show standard versions of machines. The above information is a general description only, all information's are supplied without liability.

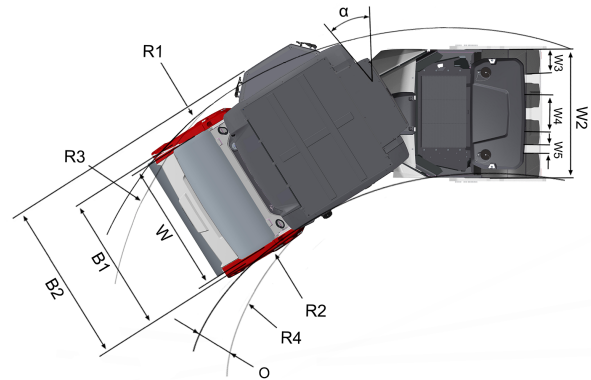
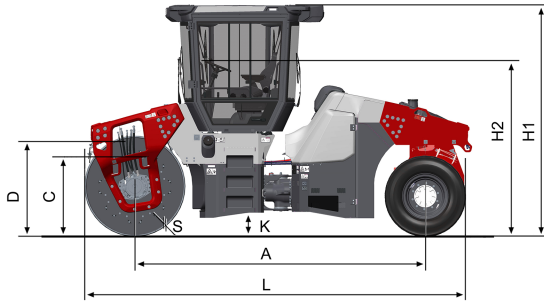

DIMENSIONS

DIMENSIONS

A. Wheelbase	146 in
B1. Width, front	86 in
B2. Width, with cab	95 in
C. Curb clearance	32 in
D. Drum diameter	51 in
H1. Height, with ROPS/cab	118 in
K. Ground clearance	12.2 in
L. Length	197 in
O. Off-set	20.5 in
R1. Turning radius, outside	292 in
R2. Turning radius, inside	215 in
R3. Turning radius with off-set, outside	220 in
R4. Turning radius with off-set, inside	143 in
S. Drum shell thickness	0.79 in
W1. Drum width	77 in
W2. Width, wheel module	63 in
W3. Width, tire	12.7 in
W4. Wheel track	18.3 in
W5. Wheel spacing	5.0 in
α. Steering angle	±32°

OPTIONAL EQUIPMENT

Air Conditioning /Automatic Climate Control (ACC) (Optional)

- The system contains fluorinated greenhouse gases.
- Coolant designation: HFC-134a
- Coolant weight when full: 1,6 kg
- CO₂-equivalent: 2,288 ton
- GWP: 1430

Find us locally at www.dynapac.com

We reserve the right to change specifications without notice. Photos and illustrations do not always show standard versions of machines. The above information is a general description only, all information's are supplied without liability.