

JB80-2
JB160-2
JB120-2
JB200-2

Capacity 17,600 / 26,400 / 35,200 / 44,000 lbs



Air hydraulic twin ram jacking beam

- Both lifting rams have ability to be operated individually or in tandem for safe operation
- Equipped with independent mechanical locking system, locking pawl engaged by gravity
- Transversely sliding rams
- Rapid and precise air hydraulic unit with high speed ram travel
- Simple modern design with control panel at ergonomical working height
- Can be made to fit all lifts due to its adjustable frame (23 1/4" - 35" or 33 1/2" - 45 1/4")
- Hold to run controls for ultimate safety
- Hydraulically protected against overloading
- Supplied with 2 x 4" extensions
+ 2 x flat adapters

Options



Diff. beam

For lifting with both rams
at one point.

Crossbeam adapters



Extensions

4 inch, 8 inch

Adapters

U-shape
V-shape

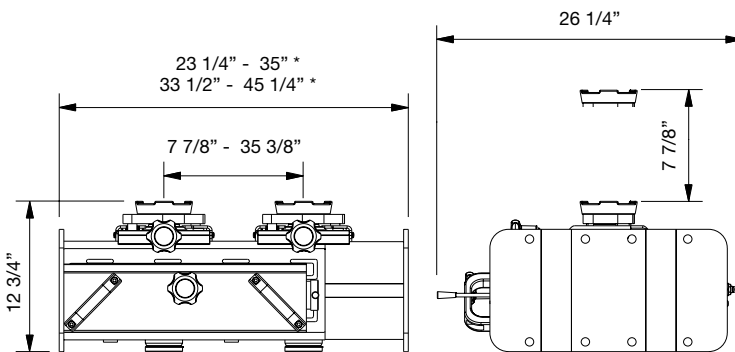

* dimensions excluding support arms

	JB80-2	JB120-2	JB160-2	JB200-2
Capacity	17,600 lbs	26,400 lbs	35,200 lbs	44,000 lbs
Stroke	7 7/8"	7 7/8"	7 7/8"	7 7/8"
Min. height	12 3/4"	12 3/4"	12 3/4"	12 3/4"
Max. height	20 5/8"	20 5/8"	20 5/8"	20 5/8"
Width range small frame	23 1/4" - 35"	23 1/4" - 35"	23 1/4" - 35"	23 1/4" - 35"
Width range wide frame	33 1/2" - 45 1/4"	33 1/2" - 45 1/4"	33 1/2" - 45 1/4"	33 1/2" - 45 1/4"
Depth	26 1/4"	26 1/4"	26 1/4"	26 1/4"
Lifting points (distance)	7 7/8" - 35 3/8"	7 7/8" - 35 3/8"	7 7/8" - 35 3/8"	7 7/8" - 35 3/8"
Air supply	116 - 174 PSI	116 - 174 PSI	116 - 174 PSI	116 - 174 PSI
Air consumption	92.5 gpm	92.5 gpm	92.5 gpm	92.5 gpm
Weight	446 lbs	446 lbs	446 lbs	446 lbs

* The capacity of the jacking beam cannot exceed 0.66 x the lift capacity

stertil KONI

 a member of the Stertil Group

Stertil-Koni U.S.A. Inc.
200 Log Canoe Circle
Stevensville, Maryland 21666
Tel. 410-643-9001
Toll free 800-336-6637
Fax 410-643-8901
lifts@stertil-koni.com

www.stertil-koni.com

 StertilKoniUSA

 @StertilKoniUSA