

Digital Ally, Inc.

Product Model:

ThermoVu Facial Recognition: DTM-700

ThermoVu DTM-700: Automatic Thermal Temperature Screening System

The ThermoVu DTM-700 is an automatic, non-contact thermal temperature-screening instrument that measures temperature through thermal imaging and controls entry to facilities when temperature measurements exceed pre-determined parameters. The DTM-700 provides real-time thermal imaging and multi-target automatic temperature screening, effective at accurately and quickly screening longer distances and large scenes. It can be widely applied in schools, office buildings, subway stations, airports, and other public venues.

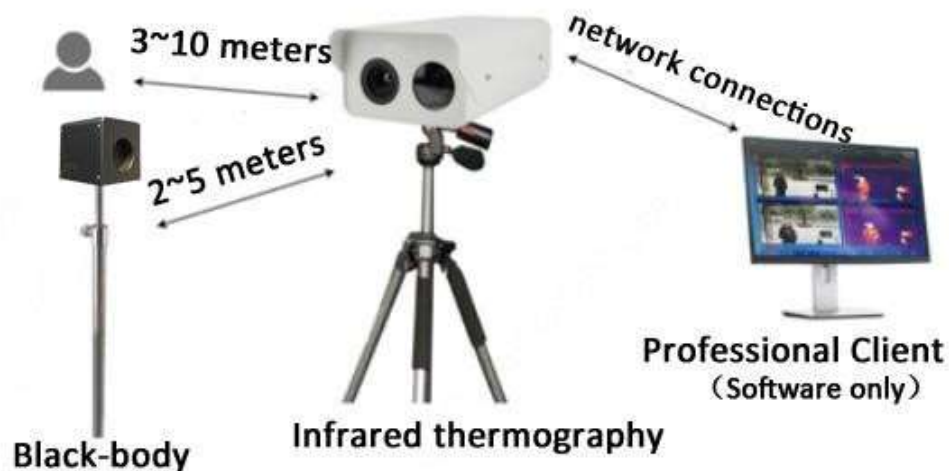

Features

- Longer distance, large scenes can also be accurately and quickly screened
- The system contains a black-body, and the temperature screening accuracy is $\leq 0.3^{\circ}$ C
- Simultaneous temperature display of visible and infrared thermal imaging
- Real-time thermal imaging, multi-target automatic temperature screening
- Support automatic capture when alarm is triggered to provide evidence after the event
- Support automatic calibration of body and surface temperature to make temperature screening more accurate
- Support historical alarm record query
- The whole system is delivered together with tripod, black body reference device, accessories and software
- One-year warranty

ThermoVu DTM-700 Specifications:

Thermal	
Sensor type	Uncooled Focal Plane Arrays
Pixel size	25µm
Maximum image size	384*288
Video frame rate	Max 25fps
NETD	≤60mk
Response waveband	8~14µm
Focal length	18mm
Iris	F1.0
Angle of View (H*V)	25°*19°
Detection distance	3~10 meters
Visible	
Sensor	1/1.8", progressive scan, CMOS
Focus	Manual
Iris	Max F1.6
	Colour : 0.001Lux(F1.6, AGC ON) B/W : 0.0002Lux(F1.6, AGC ON)
S/N	> 52dB
Defog	Optical & digital
Day/Night	IR-cut filter with auto switch (ICR)
Video Frame rate	1920*1080, Max 30fps
WDR	120dB
OSD	Up to 8 OSDs
SD card	Micro SD, up to 256GB
ANR	Support
Network protocols	IPv4, IGMP, ICMP, ARP, TCP, UDP, DHCP, PPPoE, RTP, RTSP, RTCP, DNS, DDNS, NTP, FTP, UPnP, HTTP, HTTPS, SMTP, 802.1x, SNMP, QoS
Focal length	3.8~16mm
Black-body	
Accuracy	±0.2°C (Single point)
Stability	±(0.1~0.2)°C/30min
Dimension	135mm x 135mm x150mm
Power	100V~240V AC 50/60Hz
Power consumption	60W
Radiation area	φ70mm
General	

Temperature screening accuracy	
Environment temperature range	16°C~32°C
Target temperature range	32°C~42°C
Temperature screening accuracy	≤±0.3°C
Interface	
Infrared machine head	Aviation plug
Network interfaces	RJ45
Power	
Power	DC12V
Power consumption	≤15W
Weight	
Infrared machine head	<5Kg
Black-body	<3.5kg
Function	
Alarm	Multi abnormal temperature point alarm and automatic capture
Capture	Capture when alarm is triggered
Temperature display	Simultaneous display of temperature in infrared and visible light images
Correction of body and surface	Support automatic temperature calibration
Environmental adaptability	
Working humidity	≤80%RH(non-condensing)
Notes	
PC requirement	CPU I5 or more / memory 8G. Operating system win10, 64-bit.If you have a laptop, you must have a network port.



DTM-700 Product Dimensions (Unit: mm):

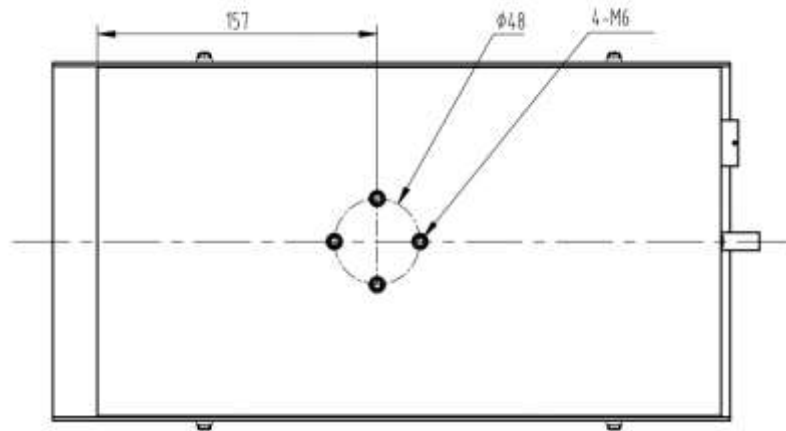
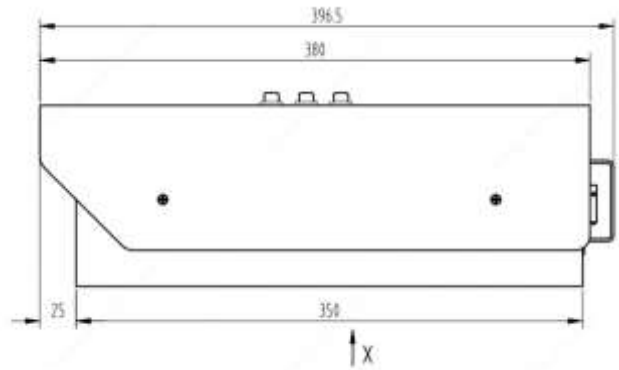
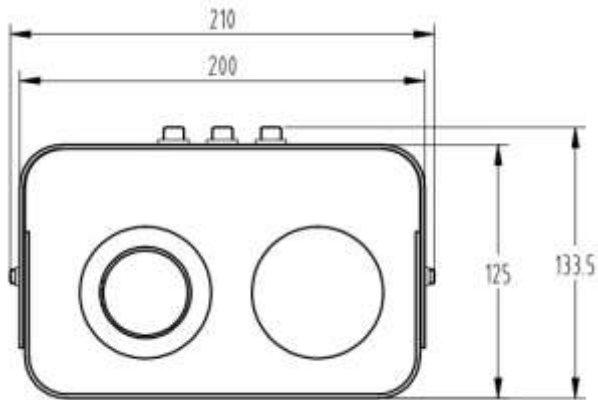

Standard components

- 1pcs Black-body
- 2pcs Tripods
- Power adapter