



Name: 4" Compressor-Assisted Solids Handling Pump

Model: 4JSC-SK

With its heavy-duty cast-iron construction and fast priming capabilities, the Thompson 4JSC-SK solids handling end suction centrifugal pump leads the industry in construction, industrial and municipal applications. The Thompson 4JSC-SK is designed for moderate flows up to 1,350 gpm and heads up to 135 feet making it perfect for sewage bypass pumping or general construction dewatering.



Photo shown may not be exact model.

Consult factory for other versions & options including site trailers, sound attenuation, etc.

Pump End Materials	
Pump Casing	Heavy-duty class 30 ductile-iron.
Impeller	Dynamically balanced, non-clogging, enclosed, 65-45-12 ductile iron with rear-equalizing vanes to reduce axial loading and prolong seal and bearing life; diameter 8.25".
Mechanical Seal	Dry-running, grease or oil lubricated with Tungsten Carbide rotating and Silicon Carbide stationary seal faces. Single inside mounted, non-pusher type with self-adjusting elastomeric bellows. Other components are 304 stainless steel and Viton.
Head	Rugged, back pull out design, heavy-duty class 30 cast iron with tapered bore design.
Bearings	Heavy-duty grease lubricated to carry both axial and radial loads.
Bearing Frame	Heavy-duty class 30 ductile iron.
Shaft	SAE 1144 fitted with 416 stainless steel shaft sleeve.

Technical Specifications			
Suction Size	4 in (10.16 cm)	Approximate Dry Weight	4,560 lbs (2,068.38 kg)
Discharge Size	4 in (10.16 cm)	Best Efficiency	71%
Maximum Solids Handling	3 in (7.62 cm)	Maximum Operating Speed	2,400 rpm
Maximum Operating Temperature	200° F (93.33° C)	Maximum Operating Pressure	58.44 psi (402.94 kPa)

Fuel Tank Options*		Isuzu	Deutz
Modular (M)	100 Gal	100 Hours	99 Hours
Double-Wall (D)	75 Gal	75 Hours	74 Hours
Modular Large Capacity (X)	150 Gal	151 Hours	149 Hours
Double-Wall Large Capacity (Z)	150 Gal	151 Hours	149 Hours

*Contact factory for fuel tank sizes not listed above.

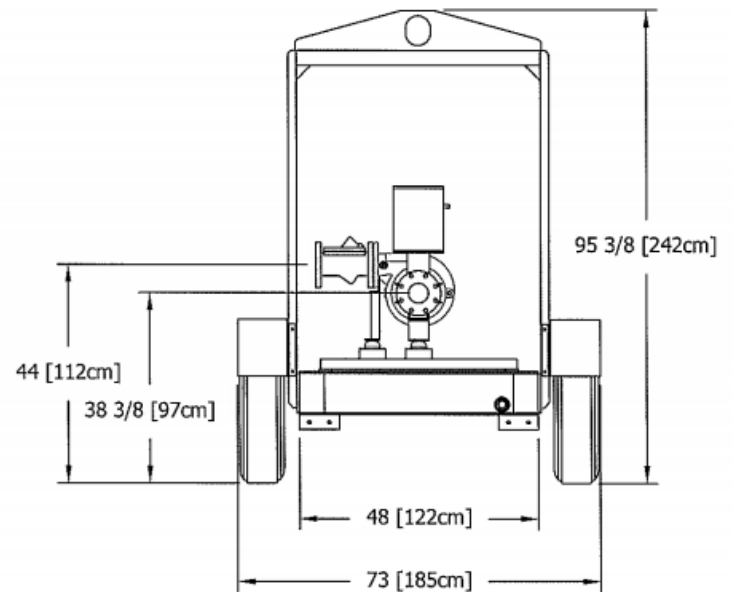
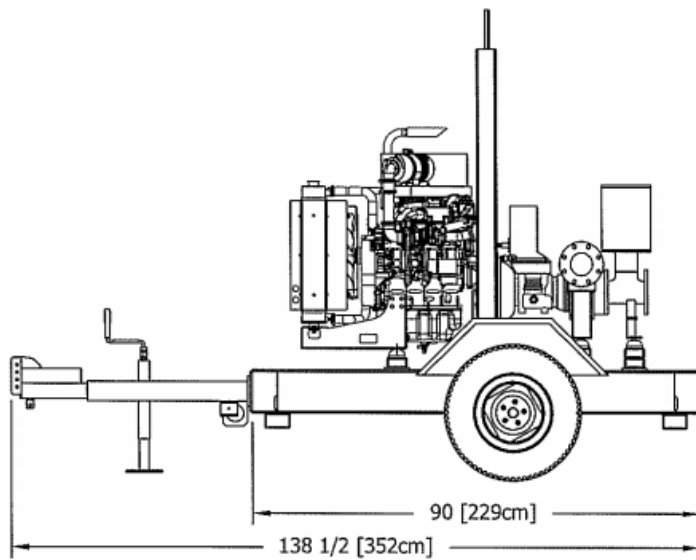
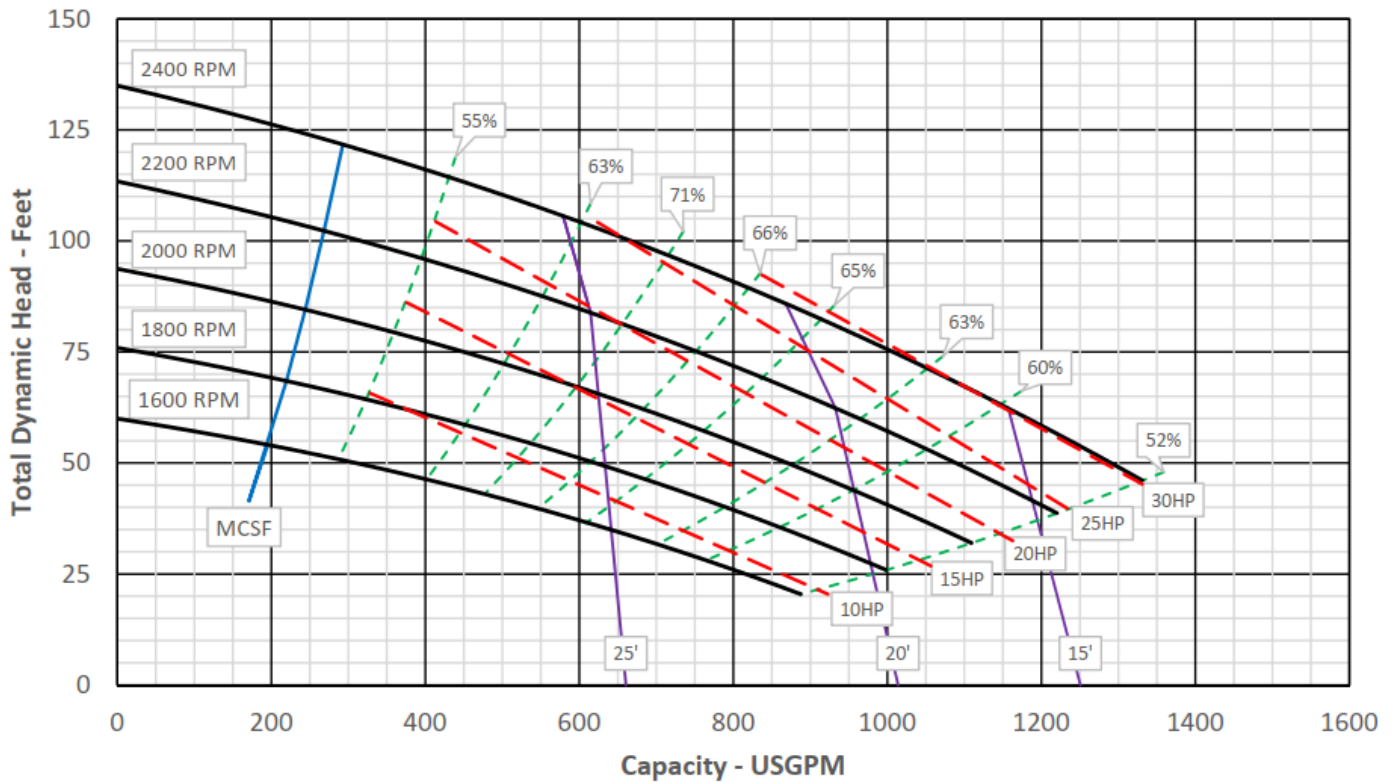

Isuzu 4LE2T—43 hp @ 2,400 rpm				
Typical Operating Speed	2,400 rpm	Engine Speed	Fuel Economy	Run Time*
Maximum Head	135 ft (22.86 m)	2,400 rpm	0.411 lb/hp-hr	47 hrs
Maximum Flow Capacity	1,350 gpm (493.72 m ³ /hr)	2,200 rpm	0.390 lb/hp-hr	66 hrs
Maximum Fuel Consumption	2.11 gph (7.99 L/hr)	2,000 rpm	0.387 lb-hp-hr	100 hrs

Deutz D2.9L4— 40 hp @ 2,400 rpm				
Typical Operating Speed	2,400 rpm	Engine Speed	Fuel Economy	Run Time*
Maximum Head	135 ft (22.86 m)	2,400 rpm	0.420 lb/hp-hr	46 hrs
Maximum Flow Capacity	1,350 gpm (493.72 m ³ /hr)	2,200 rpm	0.405 lb/hp-hr	64 hrs
Maximum Fuel Consumption	2.16 gph (8.18 L/hr)	2,000 rpm	0.390 lb-hp-hr	99 hrs

*Engine run times calculated based on a 100 gallon fuel tank.

Specifications and illustrations are subject to revision without notice and without incurring any obligation for previous or subsequent equipment sold. Thompson Pump (ISO 9001:2015) makes no representation regarding the completeness or accuracy of this information and is not liable for any direct or indirect damages arising from or relating to this information or its use. Capacity & Head are shown for comparative purposes. Consult Thompson factory for exact capabilities.



EXPERIENCE INNOVATION

Silent Knight Canopy®

Thompson Pump's Silent Knight Canopy is designed to fully contain the pump and engine in a lockable enclosure. This enclosure will reduce noise levels at, or below 74 dBA when measured from a distance of 7 meters. With a modular design, this canopy can be added to many units after the unit has already been in operation.

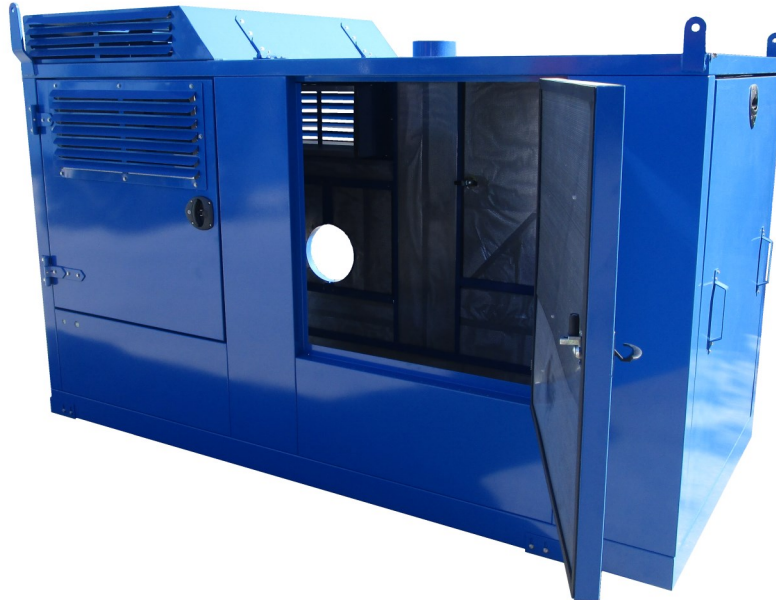

Materials

Outer Shell	18 Gauge Galvaneal Steel
Frame	14 Gauge Galvaneal Steel
Insulation	8 pound mineral wool with laminate face. 1 1/2" thick, 1" thick open-cell foam sound collars around piping
Interior Lining	Perforated aluminum 0.05 thick, 30 holes per in ² , 1/8" diameter
Coating	1-3 mil powder coating available in a variety of colors
Latches	Vector "T" handle key locking with adjustable cam (M27-LF-20-363-22P)
Hinges	Long hinge strap (M27-LF-20-363-21-2) Short hinge strap (M27-LF-20-363-21-3)
Fasteners	<ul style="list-style-type: none"> • Hex head bolts 304 stainless • Hex nuts fine thread 304 stainless • Flat washers 304 stainless • Hex head sheet metal screws or self drilling screws 304 stainless • Aluminum pop rivets • All other bolts, screws or fasteners should be 304 stainless • Hinge grease fittings 304 stainless

Thompson Pump and Manufacturing Co., Inc.
4620 City Center Drive, Port Orange, FL 32129 USA
www.thompsonpump.com

Nationwide 800-767-7310 • International +1-386-767-7310
Fax 386-761-0362
sales@thompsonpump.com

Apr-20

Specifications and illustrations are subject to revision without notice and without incurring any obligation for previous or subsequent equipment sold. Thompson Pump (ISO 9001:2008) makes no representation regarding the completeness or accuracy of this information and is not liable for any direct or indirect damages arising from or relating to this information or its use.