

With its heavy-duty cast-iron construction and fast priming capabilities, the Thompson 12JSC-LP-SK solids handling end suction centrifugal pump leads the industry in construction, industrial and municipal applications. The Thompson 12JSC-LP-SK is designed for moderate flows up to 7,550 gpm and heads up to 110 feet making it perfect for sewage bypass pumping or general construction dewatering.

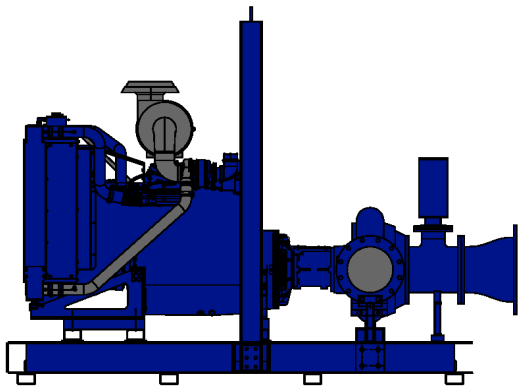

Photo shown may not be exact model.

Consult factory for other options including but not limited to trailers and stainless steel impellers.

Pump End Materials	
Pump Casing	Heavy-duty class 30 ductile iron.
Impeller	Dynamically balanced, non-clogging, enclosed, 65-45-12 ductile iron with rear-equalizing vanes to reduce axial loading and prolong seal and bearing life; diameter 12.88” x 27°.
Mechanical Seal	Dry-running, grease or oil lubricated with tungsten carbide rotating and silicon carbide stationary seal faces. Single inside mounted, non-pusher type with self-adjusting elastomeric bellows. Other components are 304 stainless steel and Viton.
Head	Rugged, back pull out design, heavy-duty class 30 cast iron with tapered bore design.
Bearings	Heavy-duty grease lubricated to carry both axial and radial loads.
Bearing Frame	Heavy-duty class 30 ductile iron.
Shaft	SAE1144 high quality stress-proof steel with 416 renewable shaft sleeve.

Technical Specifications			
Suction Size	12 in (30.48 cm)	Approximate Dry Weight	6,500 lbs (2,948 kg)
Discharge Size	12 in (30.48 cm)	Best Efficiency	73%
Maximum Solids Handling	3 in (7.62 cm)	Maximum Operating Speed	1,800 rpm
Maximum Operating Temperature	200° F (93.33° C)	Maximum Operating Pressure	47 psi (324.05 kPa)

Fuel Tank Options*	John Deere	Cummins
Modular (M)	127 Gal	37 Hours
Double-Wall (D)	94 Gal	27 Hours
Modular Large Capacity (X)	200 Gal	58 Hours
Double-Wall Large Capacity (Z)	145 Gal	42 Hours

*Contact factory for fuel tank sizes not listed above.

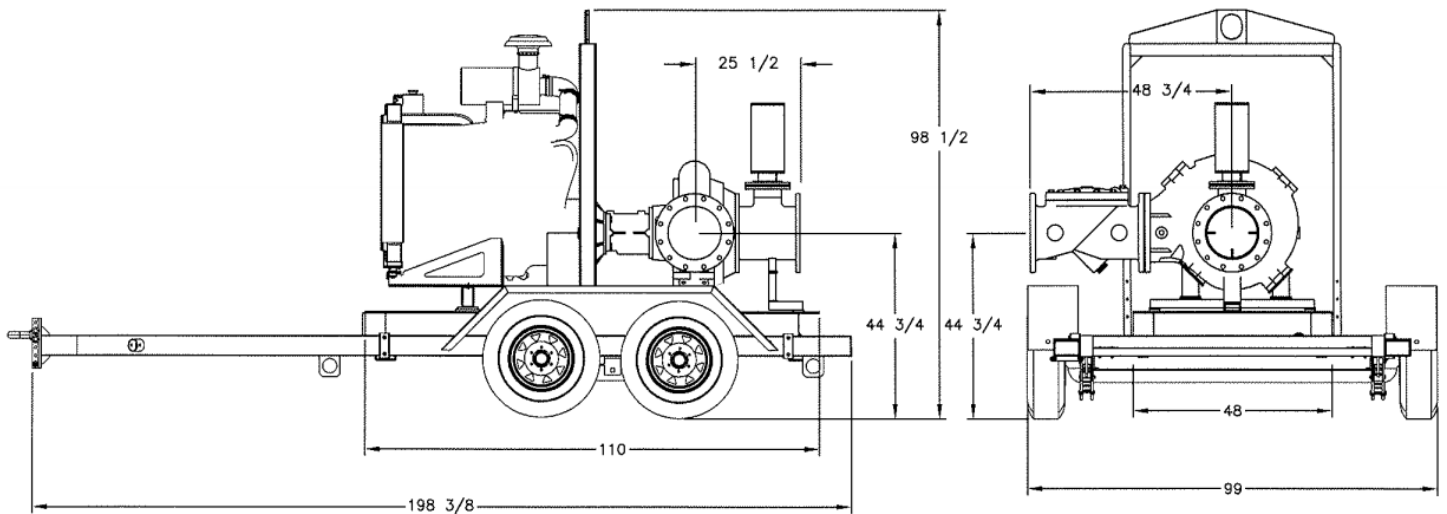
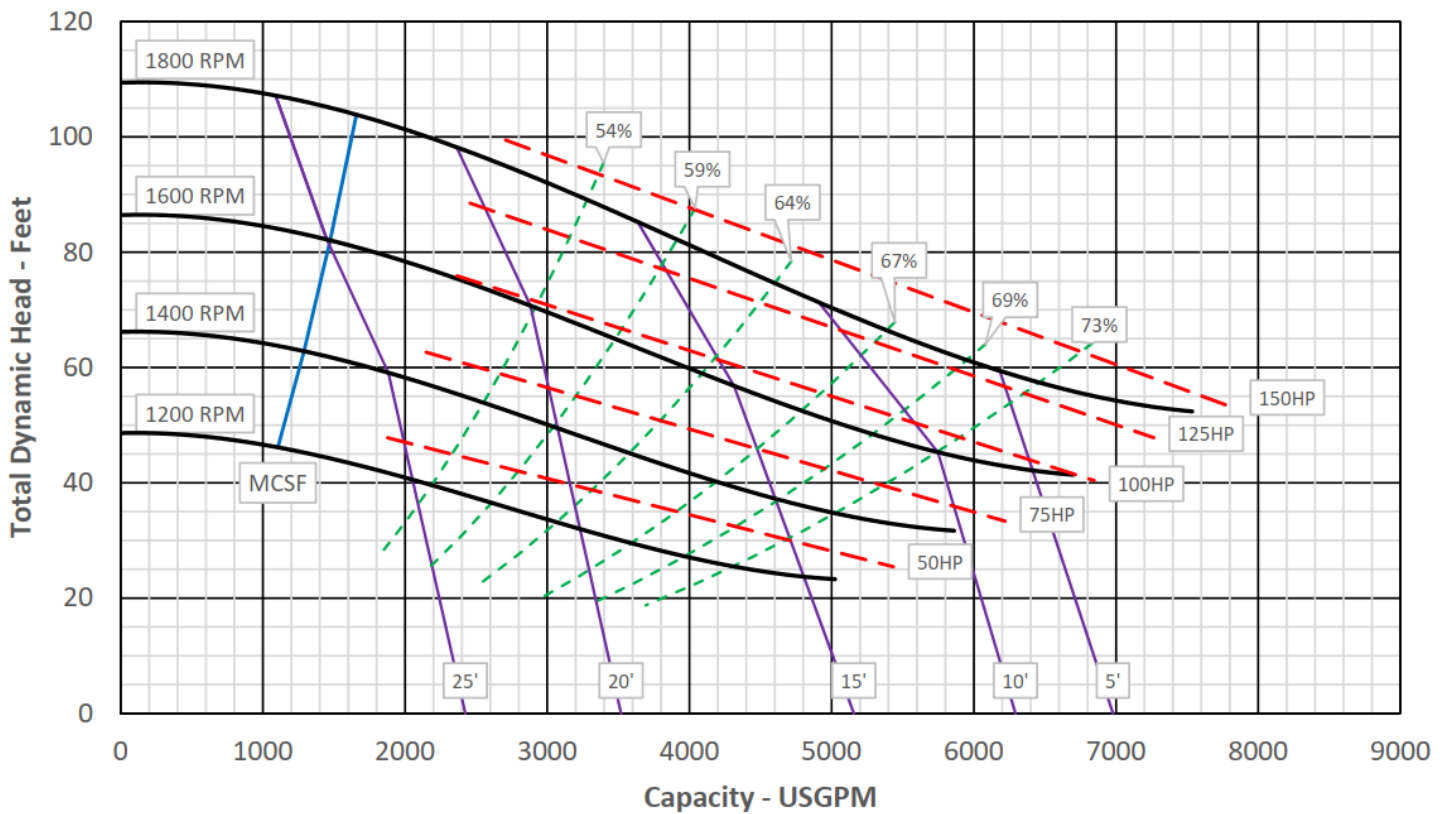

John Deere 4045HFC04— 139 hp @ 2,200 rpm				
Typical Operating Speed	1,800 rpm	Engine Speed	Fuel Economy	Run Time*
Maximum Head	110 ft (33.53 m)	1,800 rpm	0.351 lb/hp-hr	17 hrs
Maximum Flow Capacity	7,550 gpm (1,714 m ³ /hr)	1,600 rpm	0.345 lb/hp-hr	23 hrs
Maximum Fuel Consumption	7.26 gph (27.48 L/hr)	1,400 rpm	0.342 lb-hp-hr	37 hrs

Cummins QSB24.5—140 hp @ 2,200 rpm				
Typical Operating Speed	1,800 rpm	Engine	Fuel Economy	Run
Maximum Head	110 ft (33.53 m)	1,800 rpm	0.341 lb/hp-hr	18 hrs
Maximum Flow Capacity	7,550 gpm (1,714 m ³ /hr)	1,600 rpm	0.338 lb/hp-hr	23 hrs
Maximum Fuel Consumption	7.05 gph (26.69 L/hr)	1,400 rpm	0.334 lb-hp-hr	38 hrs

*Engine run times calculated based on a 127 gallon fuel tank.

Specifications and illustrations are subject to revision without notice and without incurring any obligation for previous or subsequent equipment sold. Thompson Pump (ISO 9001:2015) makes no representation regarding the completeness or accuracy of this information and is not liable for any direct or indirect damages arising from or relating to this information or its use. Capacity & Head are shown for comparative purposes. Consult Thompson factory for exact capabilities.



EXPERIENCE INNOVATION

Silent Knight Canopy®

Thompson Pump's Silent Knight Canopy is designed to fully contain the pump and engine in a lockable enclosure. This enclosure will reduce noise levels at, or below 74 dBA when measured from a distance of 7 meters. With a modular design, this canopy can be added to many units after the unit has already been in operation.



Materials

Outer Shell	18 Gauge Galvaneal Steel
Frame	14 Gauge Galvaneal Steel
Insulation	8 pound mineral wool with laminate face. 1 1/2" thick, 1" thick open-cell foam sound collars around piping
Interior Lining	Perforated aluminum 0.05 thick, 30 holes per in ² , 1/8" diameter
Coating	1-3 mil powder coating available in a variety of colors
Latches	Vector "T" handle key locking with adjustable cam (M27-LF-20-363-22P)
Hinges	Long hinge strap (M27-LF-20-363-21-2) Short hinge strap (M27-LF-20-363-21-3)
Fasteners	<ul style="list-style-type: none"> • Hex head bolts 304 stainless • Hex nuts fine thread 304 stainless • Flat washers 304 stainless • Hex head sheet metal screws or self drilling screws 304 stainless • Aluminum pop rivets • All other bolts, screws or fasteners should be 304 stainless • Hinge grease fittings 304 stainless

Thompson Pump and Manufacturing Co., Inc.
4620 City Center Drive, Port Orange, FL 32129 USA
www.thompsonpump.com

Nationwide 800-767-7310 • International +1-386-767-7310
Fax 386-761-0362
sales@thompsonpump.com

Apr-20

Specifications and illustrations are subject to revision without notice and without incurring any obligation for previous or subsequent equipment sold. Thompson Pump (ISO 9001:2008) makes no representation regarding the completeness or accuracy of this information and is not liable for any direct or indirect damages arising from or relating to this information or its use.