

**PRIME<sup>3</sup>** Vacuum Assisted Suction Pump  
Model PT6X6TMS- D3.6L4  
Size 6" Trash Pump  
138' Shut-off Head

Holland® Pump Company  
Corporate Office: 7312 Westport Pice  
West Palm Beach, Florida 33413  
United States of America  
Phone 561-697-3333  
1-800-451-0769

### **PUMP SPECIFICATIONS**

**Wetend:** 8NNDH Redi Prime **Volute:** Cast iron ASTM A48 class 30

**Impeller:** Enclosed -Delta 13.5" diameter, Handles 3.38" diameter solids

**PRIME<sup>3</sup> Priming System:** Automatic priming system that features a 50 cfm water tolerant, diaphragm vacuum pump driven by the main drive shaft. Our major competitors use a 15 cfm compressor pump with a small compressor venturi that can easily clog. The air/water separator is a simple, reliable float that opens and closes a rubber plunger as water rises and falls. A non return valve isolates the pump during priming and protects against back flow

**Wear Rings:** Replaceable. (Double wear rings available)

**Seal:** Cornell's patented Cycloseal® design with Run-Dry oil lubrication system. John Crane T-2 single mechanical seal with Viton® elastomers, stainless steel hardware and tungsten- vs. silicon carbide seal faces for abrasion resistance

**Check Valve:** Valmatic or Equal

**Shaft Sleeve:** Heat treated 416 stainless steel

**Bearings:** Heavy duty, grease lubricated, deep groove ball bearings, with a minimum of 50,000 hours bearing life

**Hardware:** Stainless steel float linkage. A positive seating vacuum priming valve prevents water carry-over to the vacuum, pump or atmosphere

**Performance:** Primes to depths of 25 feet below the center line of the pump in 1 minute

**Flanges:** 6" suction, 6" discharge

### **Output (GPM)**

#### **Performance Evaluation:**

<b>Flow</b> US gpm	<b>Speed</b> rpm	<b>Head</b> ft	<b>Efficiency</b> %	<b>Power</b> hp	<b>NPSHr</b> ft
2880	1650	41.2	46	64.9	20.9
2400	1650	63.7	57	66.5	17.4
1920	1650	83	60	66.4	13.4
1440	1650	98.4	55	63.6	10.2
960	1650	112	44	61.5	8.6

### **ENGINE SPECIFICATIONS**

**Model:** Duetz 3.6L4 HT or Equal

**Type:** 4 Cylinder, 4 Stroke, Liquid Cooled, DIVERT Oxidation Catalyst, DPF, Turbocharged Diesel Engine

**Displacement:** 3.6L (276 cu.in.)

**Governor:** Electronic

**Lubrications:** Forced Circulation

**Air Cleaner:** Dry Type with Replaceable Element

**Lube Oil Capacity:** 3.5 U.S. Quarts

**Coolant Capacity:** 5 U.S. Gallons

**Fuel Tank:** Minimum 75 U.S. Gallon Capacity (#2 Diesel Fuel)

**Full Load Operating Time:** 40 Hours @ 2000 PSI

**Starter:** 12 Volt, 2.0 kW

**Standard Features:** Cast Iron Engine Block, Flywheel and Flywheel Housing, Ecoplus Oil and Fuel Filters, Glow Plug Starting Aid, Integral Inlet and Manifold, Gear Driven Coolant Pump, Cast Iron Exhaust Manifold with Center Side Outlet, Standard Instrument Panel: Engine Temperature and Low Oil Pressure with optional Gauge, Key Start, and Hour Meter DOT Trailer, ELeetric brakes

**Optional Features:** Automatic Remote Start and Stop, NEMA 4 Instrument Package Covering: Air Filter, Fuel Filter, Engine Temperature, Fuel Level, Engine Oil Pressure, Hour Meter, Amp Meter

**Coupling:** SAE 4 Bell housing adapter, Stromag or equal coupling

**Duetz Published Performance:**

Maximum Continuous Power: 74 BHP (55.4kW) @ 2300 RPM

*Specifications subject to change without notice*

Holland® Pump Company  
Corporate Office: 7312 Westport Plce  
West Palm Beach, Florida 33413  
United States of America  
Phone 561-697-3333  
1-800-451-0769

**PRIME<sup>3</sup>** Vacuum Assisted Suction Pump  
Model odel PT8X6TMS- D3.6L4  
Size 6" Trash Pump  
138' Shut-off Head

Approximate Dimensions  
Powered by Duetz 3.6L4 HT or Equal

	Skid Base	DOT Trailer
Net Weight (lbs)	3410	4010
Shipping Weight (lbs)	3560	N/A
Export Crate Size (cu. ft)	2450	N/A

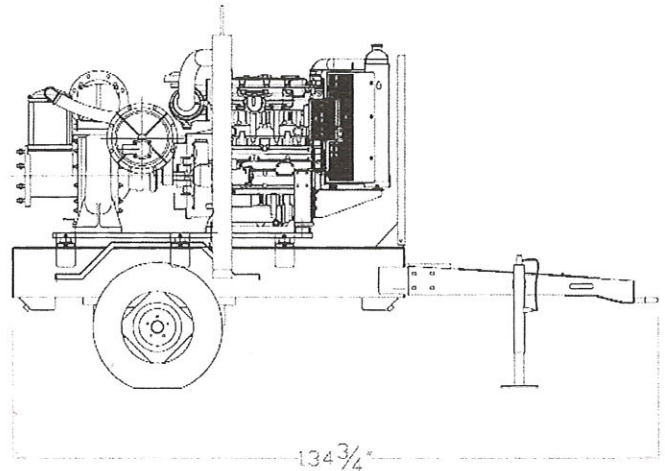
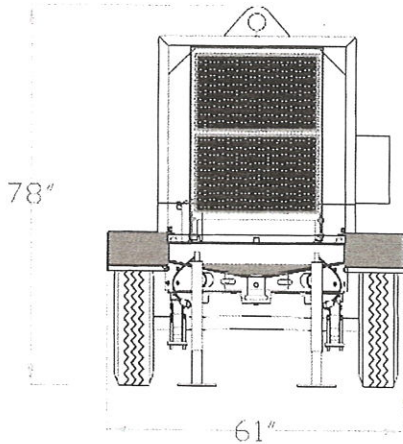

Performance Curve Model: PT8X6TMS- D3.6L4  
Size: 6" Trash, Materials, Sludge Pump

Data shown in table and curve is based on approximate pump performance at sea level with 60° F water. Larger diameter pipe may be required for maximum flows.

**--- Duty Point ---**  
Flow: 2341 US gpm  
Head: 66.6 ft  
Eff: 58.2%  
Power: 66.8 hp  
NPSHr: 17 ft  
Speed: 1650 rpm

**--- Design Curve ---**  
Shutoff Head: 138 ft  
Shutoff dP: 60 psi  
Min Flow: 400 US gpm  
BEP: 60.6% @ 1970 US gpm  
NOL Power:  
67.2 hp @ 2252 US gpm

**--- Max Curve ---**  
Max Power:  
73.9 hp @ 2361 US gpm

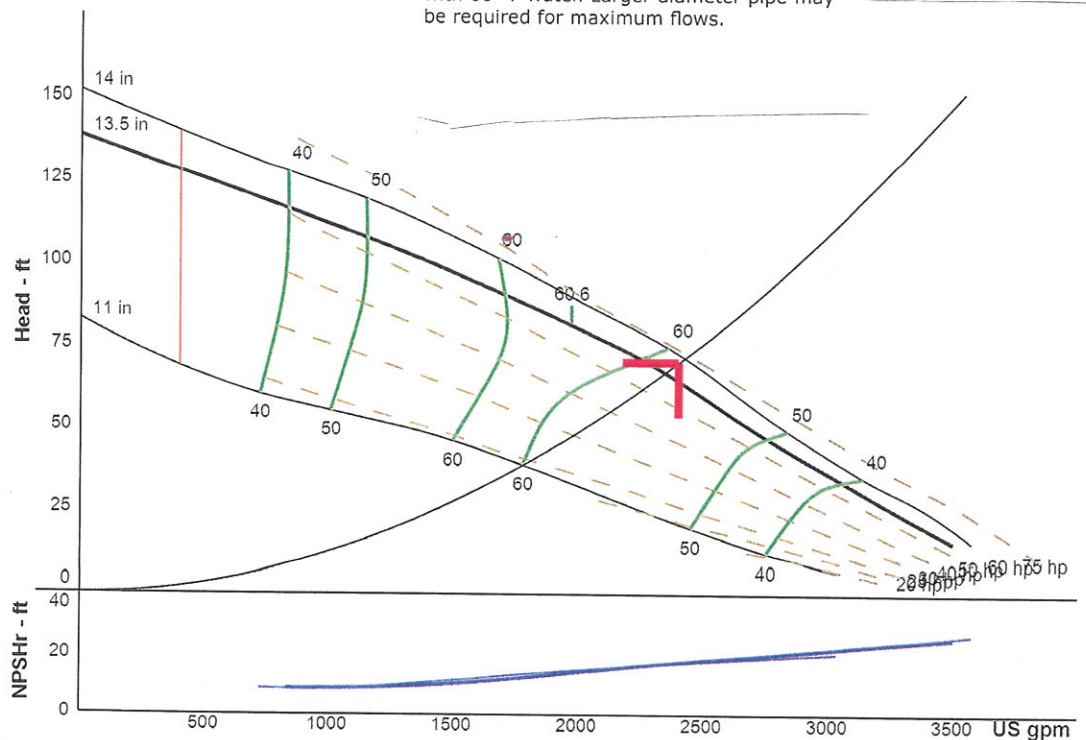

Min flow line represents the absolute lowest flow pump can operate. Consult with factory if operating below