



Division of THC Enterprises, Inc.

Easton, MD * Baltimore, MD * Chesapeake, VA Chester, PA *
Clinton, MD * Cheswick, PA * Salem, VA

Phone 800-338-7274 Fax 410-820-9916

Visit us on the web! www.mawaste.com



PROPOSAL

Remittance Address for Deposits:

10641 Cordova Road
Easton, MD 21601

SOLD TO

SHIP TO

Quote #: RSSQ37754

VSA 2022 Vacall AV

VSA

Account:

Terms:

Date: 07/06/22

Sales Rep Fred Seitz

QTY	DESCRIPTION	UNIT PRICE	EXT PRICE
1.00	Vacall AV-18	\$221,250.00	\$221,250.00
1.00	Freight		
1.00			

Subtotal	\$221,250.00
Federal Excise Tax	\$0.00
Sales Tax	\$0.00
TOTAL*	\$221,250.00

*Total does not include optional items

***F.E.T will be charged on all applicable items
unless current F.E.T Exemption form is on file.***

Any cancellation or modification of order will result in a 20% restocking charge to Buyer.



High Performance Industrial Vacuum

Superior Vacuum and Filtration Design for Greater Productivity and Longer Life

VACALL™

AllVac industrial vacuum machines deliver more years of higher performance, setting a new long-term productivity standard for the removal of dust, powders, solids, liquids and even thick slurries. A superior filtration design effectively cleans air before it reaches the heavy duty blower, capable of creating maximum vacuum at 28" Hg and maximum air flow at 5760 CFM. As an added benefit, AllVac machines have one engine, reducing fuel consumption, emissions, noise and maintenance requirements.

FEATURES & BENEFITS



Air cannon cleaning

Bag pulsation operates without interruption, thanks to an air cannon filter cleaning system that resets after every cycle. Strong steel pipe delivers the air blast, while the entire system eliminates spills from manual bag house unloading.



Superior bag filtration system

Universal snap-ring filter bags maximize the volume of available clean airflow around each filter, also making it easier for material to be blasted off effectively.

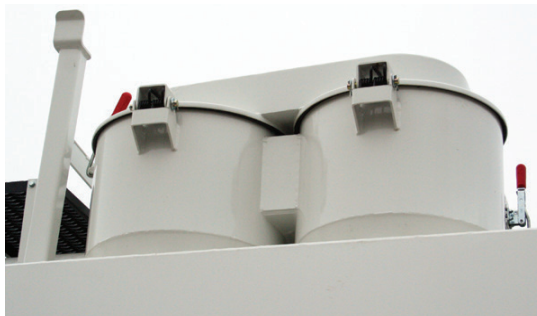

True single mode filtration

Twin cyclone pre-filters ensure that wet and fine dry materials are removed before they reach the bag house.



Fast decontamination

Decontaminating a truck before it leaves a plant can take only a few minutes with a hinged twin-cyclone top door, permitting instant access to all duct work.

VACALL™

Fail safe tailgate

Designed to be operated by one man, tailgate movement is smooth and leak-free with a simple opening/closing/locking system using one hydraulic cylinder. Tailgate system features, sealed wiring, tail lights, optional ladder and platform and more. Dumping can be augmented with an optional vibrator.



Sure-footed maintenance

Slip-resistant steps and optional platforms are conveniently located throughout the power train area. Valves and filters do not require crawling over or under components.

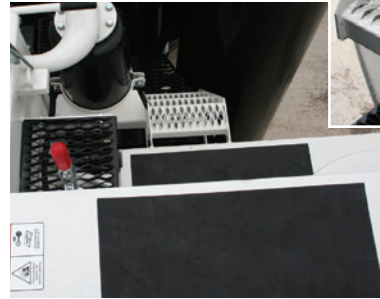

Easy-to-understand control panel

For simplified troubleshooting and maintenance, a single multi-pin connector joins the control panel with circuit breakers to the electrical harness. An inscribed wiring diagram maps the course of every wire. Wires and terminal strips are labeled.



Exclusive poured-in gasket (PIG) seals

Contoured PIG gaskets – a Vacall exclusive – deliver long life with extreme toughness and resistance to both acids and alkalis.



Oversized dump chutes

All material dumps freely through large, smooth, rounded dump chutes. Bolt-on, modular dump chutes (shown) are standard.



One-man safety prop

Easy to operate and visible from the operator's control panel, this standard protective feature allows safe engagement of the body prop by one person.

Vacall AllVac machines are ideal for:

- Chemical plants
- Cement plants
- Steel and aluminum plants
- Dust collectors
- Tanks
- Foundries
- Power generating stations
- Mining
- Grain elevators and silos
- Oil refineries
- Sewer treatment plants
- Shipyards and docks
- Phosphate plants
- Waste-to-energy plants
- Furnaces

Certified ISO 9001 • 2/12
Form No. 11311 • Printed in U.S.A

Vacall machines are designed and manufactured by Gradall Industries, Inc., a world leader in the production of versatile, reliable maintenance machines. It is our policy to continually improve our products. Therefore, designs, materials and specifications are subject to change without notice and without incurring any liability on units already sold. NOTE: some options shown in pictures.

VACALL™

Gradall Industries, Inc. • 406 Mill Ave SW • New Philadelphia, OH 44663
Phone: (330) 339-2211 • Toll-Free: (800) 382-8302 • Fax: (330) 339-8468
www.vacallindustries.com

GRADALL
INDUSTRIES, INC.
Where Ingenuity Works

A ALAMO GROUP

VACALL™

AllVac

AllVac



SPECIFICATIONS

BLOWER

Blower - Roots
 Model: 1125 DVJ Tri-Nado
 Type: Tri-Lobe Direct Drive
Drive - OMSI air-shift transfer case, power frame-mounted
Speed - 2,000 RPM
Blower Vacuum - 27" HG (685.8mm)
Blower Airflow - 2,812 CFM @ 27" HG (79.6m³/min @ 685.8mm HG), 5,800 CFM (164m³/min) free air

DEBRIS TANK

Volumetric Capacity - 18 yds.³ (13.8 m³)
Dump Angle - 40°
Sides - .250" thick steel
Construction - 91" (2.3mm) diameter rolled steel plate, debris body, baghouse & dump chute are integrated, welded construction allowing for complete removal of all debris when dumping
Lifting - Hydraulic 2-stage telescopic cylinder
Tailgate - Heavy-duty rear, full 90° hydraulically opening with dual positive locking reverse angle wedges
Debris Body Safety Prop - Single, manually-operated prop located on hoist frame near rear axle(s)
Tailgate Safety Prop - Located outside beside tailgate driver side
Body Dumping Controls - Manually-operated spool-type hydraulic control valve

CONTROLS

Control Panel - Heavy-duty water-resistant steel housing with lockable door, includes: air pressure gauge, vacuum gauge, tachometer with hourmeter, throttle control, emergency stop, control panel light, vacuum relief, blower temperature gauge, pulsation control with timer for baghouse cleaning & switches for optional lights
Blower - Engaged via air-shifted transfer case
Hydraulics - Engaged via air-shifted transfer case
Body Dump & Tailgate - Open & close functions via manually-operated spool-type hydraulic control valve

FILTRATION

Debris Tank Chains - Optional chain filters for both debris tank inlet & outlet
Dual Cyclone Filters - Self-cleaning with sealed cleanout door at bottom of dump chute
Baghouse - Contains 60 easily removable/replaceable bags with sealed cleanout door at the bottom of baghouse, optional air cannon for reverse air flow bag cleaning

HYDRAULIC SYSTEM

Hydraulic Pump - Fixed displacement gear pump for reliability & simplicity with JIC fittings
Hydraulic Reservoir - 80 gallon (302.8L)
Suction Filter - 150 micron
Return Filter - 10 micron

GENERAL SPECIFICATIONS

Drive - Split-shaft PTO with direct drive to blower
Silencer - Inlet & outlet silencers based on blower requirements
Electrical - 12 Volt, all connections identified & labeled in the control box

OPTIONS

Wireless Pendant - Controls vacuum relief & engine RPM
Sludge Pump
Brass Slam Valve
Baghouse Air Cannon - For reverse air flow bag cleaning with pulsation timer
Full Load Indicator
Hydraulic Debris Body Vibrator
Platforms & Steps
Manual or Hydraulic Boom
Work Lights
Strobe Lights
Tool Boxes

VACALL

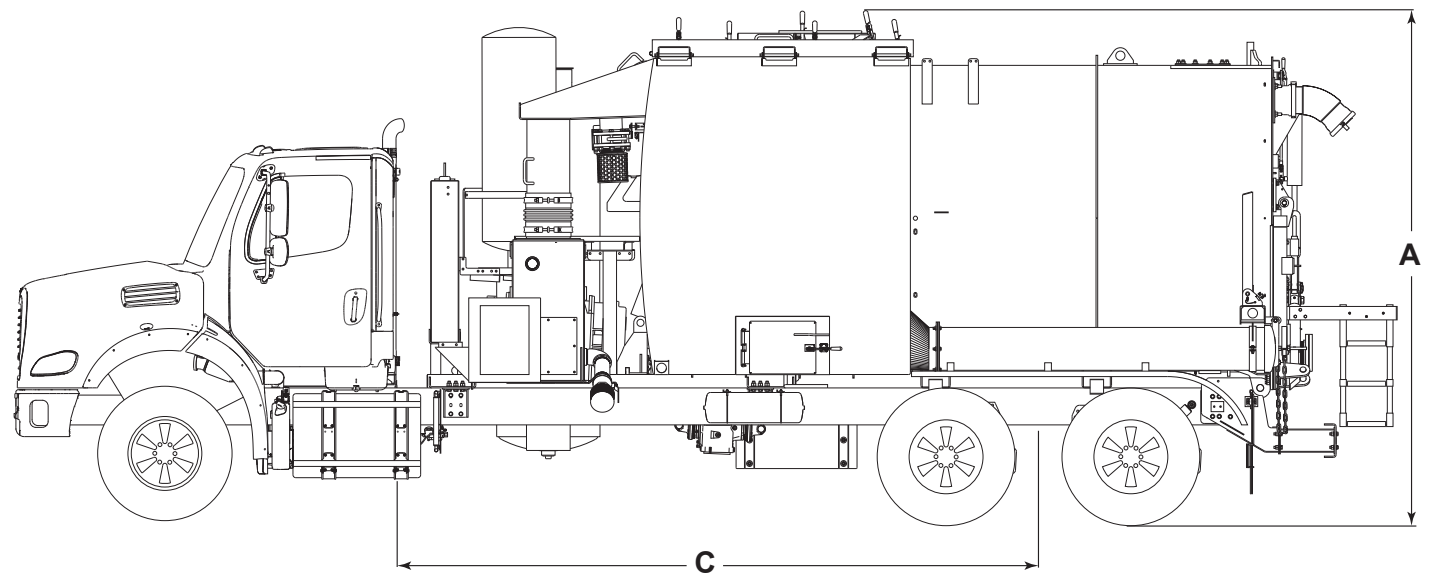
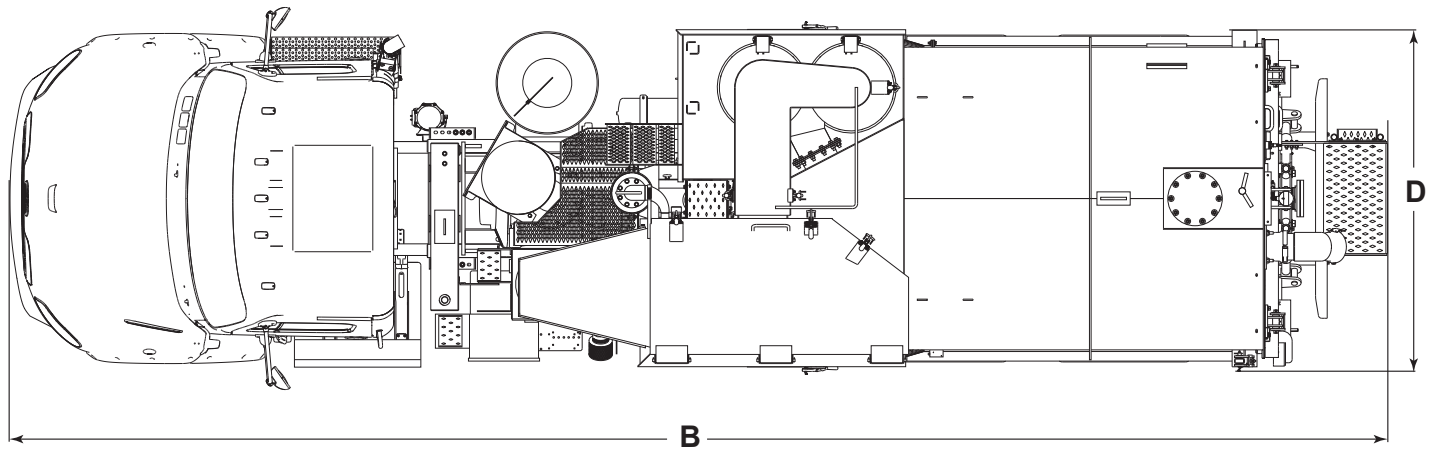

DIMENSIONS	MACHINE MODEL NUMBERS
	AVRB18
A. Overall Height	12' 9", (3.9m)
B. Overall Length	34' 4", (10.5m)
C. Clear CA Required	191.5", (4.9m)
D. Overall Width	8'10", (2.7m)

NOTE: All dimensions shown are applicable to Freightliner 114-SD Chassis only.

Certified ISO 9001 • 7-12

Form No. 11844 • Printed in U.S.A.

Vacall machines are designed and manufactured by Gradall Industries, Inc, a world leader in the production of versatile, reliable maintenance machines. It is our policy to continually improve our products. Therefore, designs, materials and specification are subject to change without notice and without incurring liability on units already sold. NOTE: some options shown in pictures.

VACALL

Gradall Industries, Inc. 406 Mill Ave SW New Philadelphia, OH 44663
 Phone: (330) 339-2211 Toll Free: (800) 382-6301 Fax: (330) 339-8468
 www.vacall.com

GRADALL
 INDUSTRIES, INC.
Where Ingenuity Works

A ALAMO GROUP