

PRODUCT SPEC SHEET BOOKLET

Collection of our 2021 Hoist System & Truck Bodies



To find more information visit switchngo.com/products



Interchangeable Truck Body System

HOIST SYSTEM



Body Hold Downs

Universal design to secure multiple body lengths* with one system
*Bodies must be system length or shorter

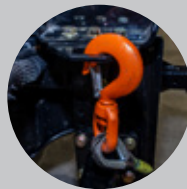

Hook Point

Integrated cable hook stowing on both sides of system

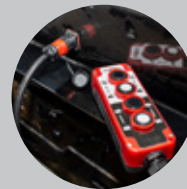

Pendant Control

Simple design for single-handed operation



Swivel Hook

Reduces cable stiffness for improved cable spooling and body attachment

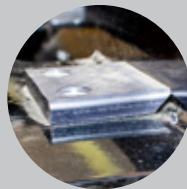

Slide Pads

Provide low friction body support and reduced wear on the system/body rails



Body Rollers

Single piece, self-greasing and bolt-on design for smooth rolling

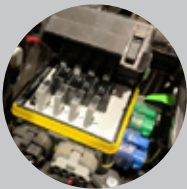

Electronics System

Fully enclosed and waterproof junction box with an IP 66 rating



V Roller

Poly material to reduce excessive wear and extends cable life



Pump Cover

Provides additional protection to the pump

Features

- Ideal for chassis cab vehicles with a GVWR of 13,500-33,000lbs
- Compatible with vehicles ranging from 60" CA to 138" CA
- Bolt on design allows for easy transfer between chassis
- Easy single handed operator controls with in-cab and on-hoist connection points
- Strong, lightweight system to maximize truck payload
- Variety of dump capacities up to 12.6 tons
- Hoist System can raise up to 50° dump angle
- Self-engaging front body Lock to secure body during transport and dumping



E SERIES HOIST SYSTEM

E Series | Is an electric powered hydraulic hoist system built for medium duty workloads and is ideal for class 4-7 chassis cab vehicles with a GVWR of 13,500lbs-26,000lbs. The system is designed to handle six fully loaded winch draws per day.*

15,000 lbs

IDEAL FOR
M DUTY
WORKLOADS

6
LOADED
LIFTS

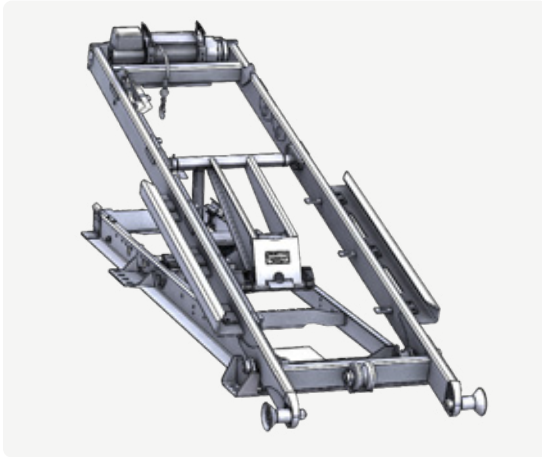

Model Name	Dumping Capacity (tons)	Minimum CEF (in.)	Winch Capacity (lbs)	Overhang Length (in.)	Typical CA (in.)
9-4016-15ES-11T	11.4	108" (9')	15,000	6"	60"
11-4016-15ES-9T	9.2	132" (11')	15,000	6"	84"-96"
11-4016-15E-10T	10.3	132" (11')	15,000	18"	84"-96"
11-4020-15E-12T	12.6	144" (12')	15,000	18"	84"-96"
12-4020-15E-11T	11.3	144" (12')	15,000	18"	96"-108"
14-4020-15E-9T	9.3	168" (14')	15,000	18"	120"-138"
14-5020-15E-10T	10.3	168" (14')	15,000	18"	120"-138"

*A fully loaded winch draw is equal to the rating of the winch, which is 15,000lbs. If you are loading 15,000lbs (body and payload), the system can pull six loads per day. If you are loading a lesser weight, the system will be able to pull more than six loads per day. For example, if your load is 10,000lbs (body and payload), the system can pull approximately 10 loads per day.

*Refer to your vehicle operator guide for manufacturer recommendations on GVWR

H SERIES HOIST SYSTEM

H Series | Is a full hydraulic hoist system built for heavy duty workloads and is ideal for class 5-7 chassis cab vehicles with a GVWR of 16,001lbs-33,000lbs

UP TO
18,000 lbs

IDEAL FOR
H DUTY
WORKLOADS

UNLIMITED
LIFTS



Model Name	Dumping Capacity (tons)	Minimum CEF (in.)	Winch Capacity (lbs)	Overhang Length (in.)	Typical CA (in.)
11-4016-15H-10T	10.3	132" (11')	15,000	18"	84"-96"
11-4020-18H-12T	12.6	144" (12')	18,000	18"	84"-96"
12-4020-18H-10T	11.3	144" (12')	18,000	18"	96"-108"
14-5020-15H-10T	10.3	168" (14')	15,000	18"	120"-138"
14-5020-18H-10T	10.3	168" (14')	18,000	18"	120"-138"

Specifications are subject to change without notice. The Gross Vehicle Weight (GVW) or Gross axle weight rating (GAWR) will limit the operating capacity of the vehicle upfitted with a hoist system. For Switch-N-Go® product warranty information, please refer switchngo.com/warranty.



Interchangeable Truck Body System

DUMP BODY



SWITCHNGO.COM



Features

- High quality zinc prime & powder coated finish
- Ramp gate for drive-on convenience
- Accepts underbody salt spreader
- 12" side height & 24" tailgate height
- Optional extended board pockets
- Standard 6" steel dump body ground rollers
- Custom options available

TO FIND A DEALER IN YOUR AREA

SWITCHNGO.COM/DEALER



TRUCK BODY OPTIONS



Coal Chute



18" Cab Shield



Welded D-rings

SPECIFICATIONS

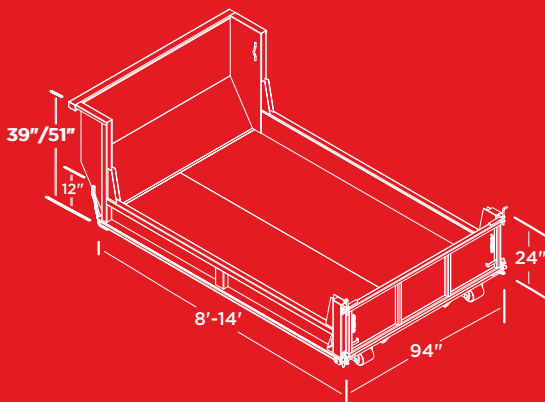

	STANDARD DUTY	HEAVY DUTY
FLOOR	10 GA	10 GA
CROSSMEMBERS	3" STRUCTURAL CHANNEL 16" ON CENTER	3" STRUCTURAL CHANNEL 16" ON CENTER
SIDES	12 GA SHEET	
TOP RAIL	3" X 3" X 1/8" TUBING	
BULKHEAD	INSIDE HEIGHT 39", 44", OR 51"	
TAILGATE	2" X 2" X 3/16" TUBING & 10GA SHEET	

Specifications are subject to change without notice. For warranty information on this or any other Switch-N-Go® product please refer switchngo.com/warranty.



Interchangeable Truck Body System

DROP BOX



SWITCHNGO.COM

Features

- High quality zinc prime & powder coated finish
- Sloped front for easy clean out
- Two build grades available
- Standard 6" steel ground rollers
- Custom options available

TO FIND A DEALER IN YOUR AREA

SWITCHNGO.COM/DEALER



TRUCK BODY OPTIONS



Curbside Door



Single swing or barn doors



Welded D-rings

SPECIFICATIONS

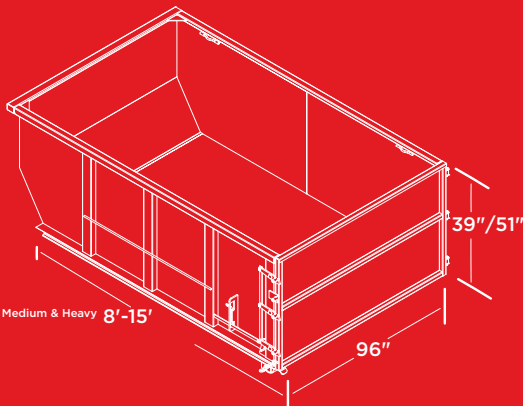

	MEDIUM DUTY	HEAVY DUTY
FLOOR	10 GA	3/16"
SIDE POSTS	2-3 POSTS PER SIDE PER SIDE 12 GA SHEET	30"-36" ON CENTER POSTS 12 GA SHEET
CROSSMEMBERS	3" STRUCTURAL CHANNEL 16" ON CENTER	3" STRUCTURAL CHANNEL 12" ON CENTER
TOP RAIL	3" X 3" X 1/8" TUBING	
TAILGATE	3" STRUCTURAL CHANNEL 16" ON CENTER	3" STRUCTURAL CHANNEL 16" ON CENTER
SIDE HEIGHTS	39" & 51"	36" & 48"
SIDES/FRONT/TAILGATE	12 GA SHEET	
REAR CORNER POST	7 GA SHEET	

Specifications are subject to change without notice. For warranty information on this or any other Switch-N-Go® product please refer switchngo.com/warranty.



Interchangeable Truck Body System

DUMPSTER BODY



FORMED TOP RAIL



3"X3" TUBING TOP RAIL

Features

- High quality epoxy prime & wet paint black finish
- Interior & bottom flat black primer
- Sloped front for easy clean out
- Single dumpster grade available
- Standard 6" steel ground rollers

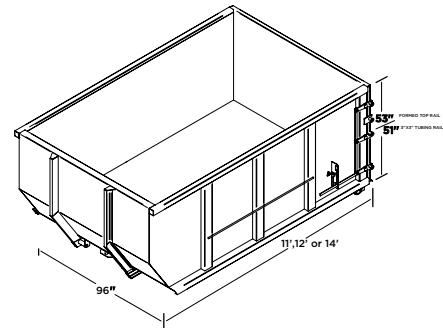

SPECIFICATIONS

	FORMED TOP RAIL			TUBING TOP RAIL		
TOP RAIL	FORMED TOP RAIL			3" X 3" x 1/8" TUBING		
SIDE HEIGHT	53"			51"		
CROSS MEMBERS	FORMED 3" CROSS MEMBERS ON 18" CENTERS					
TAILGATE	2" X 2" X 1/8" TUBING TUBULAR FRAME WORK SINGLE SWING GATE					
SIDES/FRONT/TAILGATE	12 GA SHEET					
REAR CORNER POST	12 GA SHEET					
FLOOR	12 GA SHEET					
OPTIONS/D-RINGS/SEAM SEAL	NONE					
AVAILABLE SIZES	11'	12'	14'	11'	12'	14'
APPROXIMATE HEAPED CUBIC YARDS	15YD	16YD	20YD	14YD	15YD	17YD
WEIGHT	2,030lbs	2,160lbs	2,380lbs	2,080lbs	2,210lbs	2,440lbs

Specifications are subject to change without notice. For warranty information on this or any other Switch-N-Go® product please refer switchngo.com/warranty.



Interchangeable Truck Body System

ARBOR BODY WITH REMOVABLE ROOF



SWITCHNGO.COM



Features

- High quality zinc prime & powder coated finish
- Sloped front for easy clean out
- Rear gate available in three heights
- Removable chipper roof
- Standard 6" steel ground rollers
- Custom options available

TO FIND A DEALER IN YOUR AREA

SWITCHNGO.COM/DEALER



TRUCK BODY OPTIONS



Optional 24" Rear Cover Plate



Removable Chipper Roof



Single Swing or Barn Doors with Optional Chipper 39"/36" or 24" Heights



SPECIFICATIONS

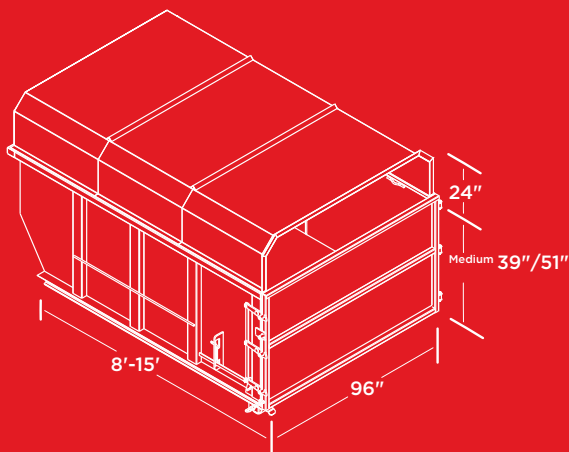

MEDIUM DUTY WITH REMOVABLE ROOF

FLOOR	10 GA
SIDE POSTS	2-3 POSTS PER SIDE 12 GA SHEET
TAILGATE	2" X 2" X 1/8" TUBING TUBULAR FRAME WORK FORMED 12GA SHEET
TOP RAIL	3" X 3" X 1/8" TUBING
ROOF	12 GA SHEET 24" HIGH WITH TOP SUPPORT 2" X 2" X 1/8" AND 8" ANGLE EDGE MESH VENTS ON BOTH SIDES
BULKHEAD	12 GA SHEET

Specifications are subject to change without notice. For warranty information on this or any other Switch-N-Go® product please refer switchngo.com/warranty.



Interchangeable Truck Body System

STORAGE BODY



Features

- High quality zinc prime & powder coated finish
- Lockable security-style doors
- 72" side height & 6" peak roof
- Standard 6" steel ground rollers
- Custom options available

TO FIND A DEALER IN YOUR AREA

SWITCHNGO.COM/DEALER



TRUCK BODY OPTIONS



Standard Exterior Posts



Optional Internal Posts



Lockable Security Style Doors



Welded D-rings

SPECIFICATIONS

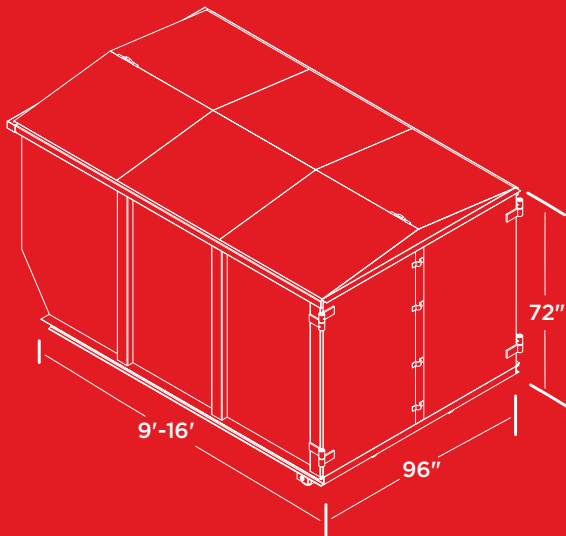

EXTERIOR POST	12 GA WITH 5" FORMED POST ON 36"-48" CENTER
INTERIOR POST	3" STRUCTURAL CHANNEL
DOORS	LOCKABLE SECURITY-STYLE WITH 3" x 3" SUPPORTS
CROSSMEMBERS	3" STRUCTURAL CHANNEL ON 16" CENTER
PEAK ROOF	6" HIGH 12 GA SHEET
TOP RAIL	3" X 3" X 1/8" TUBING
FLOOR	10 GA SHEET
BULKHEAD	12 GA SHEET

Specifications are subject to change without notice. For warranty information on this or any other Switch-N-Go® product please refer switchngo.com/warranty.



Interchangeable Truck Body System

FLATBED



SWITCHNGO.COM



Features

- High quality zinc prime & powder coated finish
- Lightweight design
- 24" on center stake pockets
- Lasercut window in bulkhead
- 4-Corner chain keyholes
- Low profile 4" steel ground rollers
- Custom options available



Distributor Info:



TO FIND A DEALER IN YOUR AREA

SWITCHNGO.COM/DEALER



TRUCK BODY OPTIONS



Welded D-rings

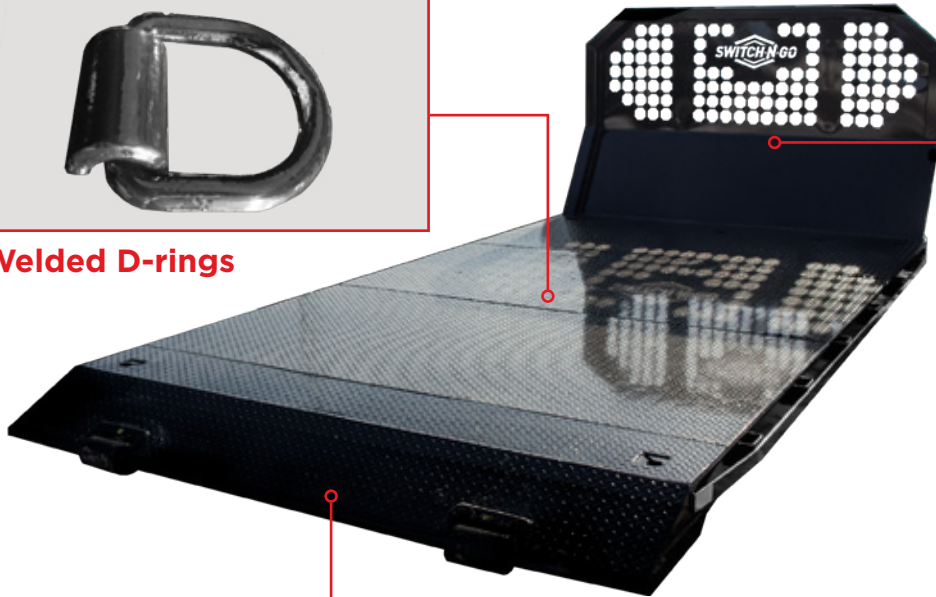

39" Height Bulkhead



51" Height Bulkhead



Optional No Beavertail w/
6" Ground Rollers

SPECIFICATIONS

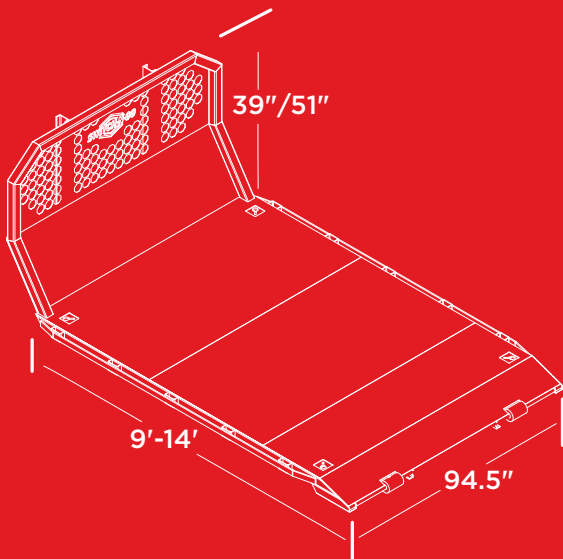

	9-12' LENGTHS	13-15' LENGTHS
FLOOR	1/8" DIAMOND PLATE	3/16" DIAMOND PLATE
OUTER RAIL	3" x 3" x 1/8" TUBING	
STAKE POCKETS	24" ON CENTER	
RUB RAIL	3/8" X 2" FLATBAR	
ROLLERS	INTEGRATED 4" X 6" WIDE GROUND ROLLERS	
CROSSMEMBERS	3" STRUCTURAL CHANNEL ON 16" CENTERS	
KEYHOLES	LOCATED IN CORNERS OF PLATFORM FLOOR	
	STANDARD BULKHEAD	HIGH BULKHEAD
BULKHEAD WINDOW	≈ 3.8 SQ FEET AREA	≈ 4.4 SQ FEET AREA

Specifications are subject to change without notice. For warranty information on this or any other Switch-N-Go® product please refer switchngo.com/warranty.



Interchangeable Truck Body System

SUBFRAME

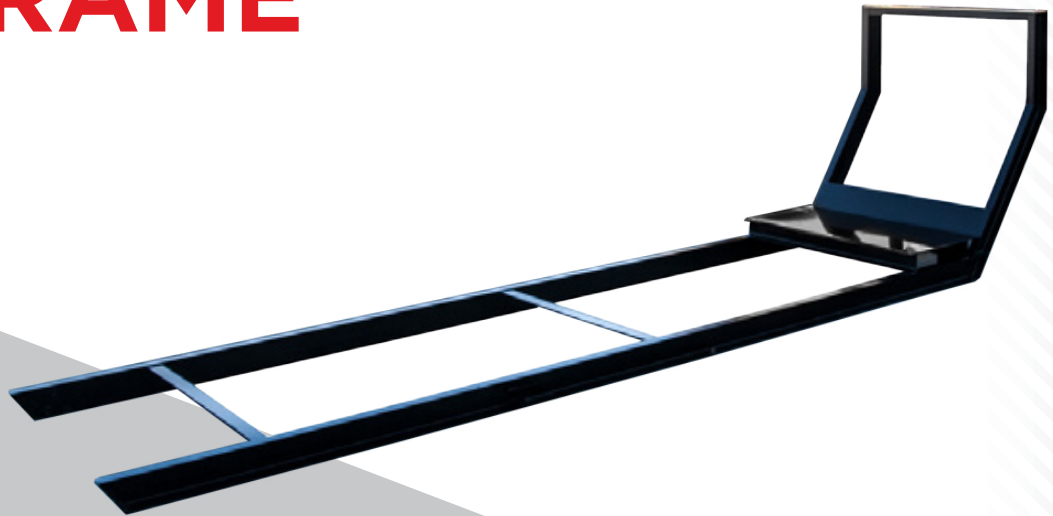

Features

- High quality zinc prime & powder coated finish
- Lightweight design
- Rail Slides w/ no wheels
- Ideal for custom usage

SWITCHNGO.COM

TO FIND A DEALER IN YOUR AREA

SWITCHNGO.COM/DEALER



FEATURES

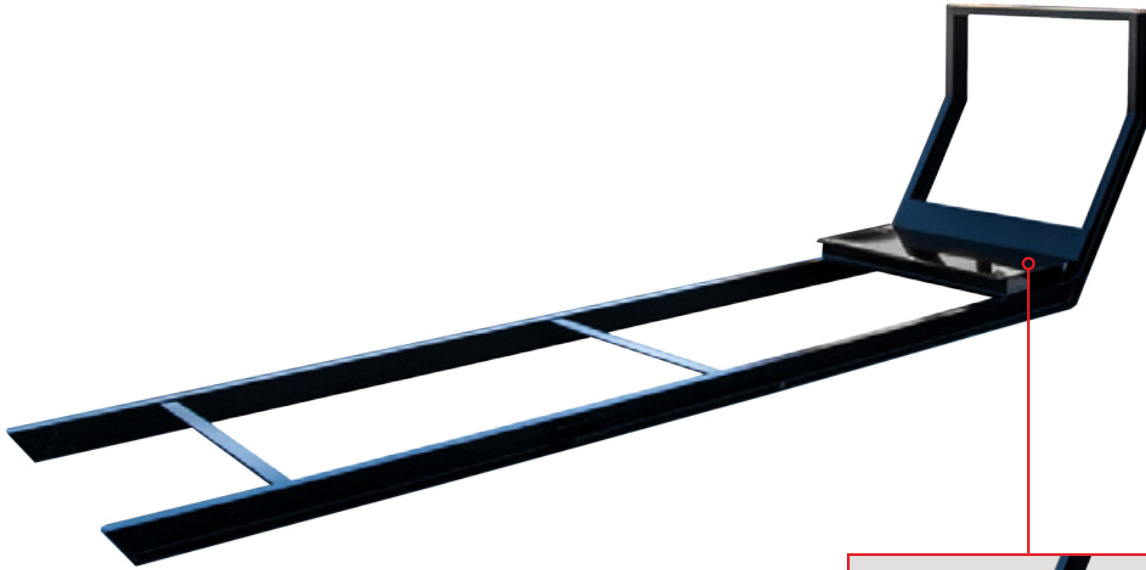

Reinforced Plate

SPECIFICATIONS

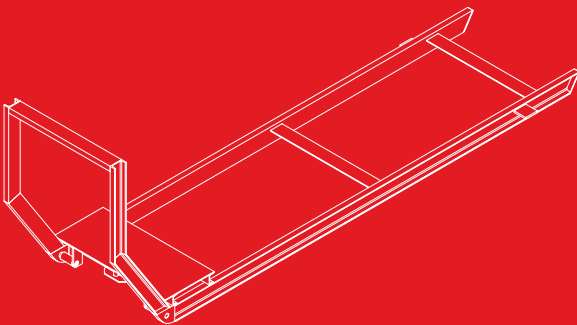

12' SUBFRAME | 16' SUBFRAME

REINFORCED PLATE 7 GA WITH PLATE WITH 4" STRUCTURAL CHANNEL

OUTER RAIL 4" x 5.4# CHANNEL | 5" x 6.7# CHANNEL

CROSSMEMBERS 3" STRUCTURAL CHANNEL ON 13" CENTERS

Specifications are subject to change without notice. For warranty information on this or any other Switch-N-Go® product please refer switchngo.com/warranty.



Interchangeable Truck Body System

WORKREADY SUBFRAME



SWITCHNGO.COM



Features

- High quality zinc prime & powder coated finish
- Engineered to maximize legal payload
- Prevents material build-up
- 10,000lb maximum load operation



TO FIND A DEALER IN YOUR AREA

SWITCHNGO.COM/DEALER



FEATURES



Retractable Legs



Detachable 6" Ground Rollers



Simple Frame Bulkhead for Maximized Visibility



Expanded Steel Side-deck



D-ring Mounts

SEE THE POSSIBILITIES



Cold Mix / Patch



Sand Blaster / Compressor



Liquid Application



Material Sprayer



Seal / Asphalt Coating



Pavement Sweeper



Water or Liquid Tank



Hydroseeder



Fuel / Lube Unit



Pressure Washer



Sand / Salt Sprayer



Pavement Marking & Striping



Sewer Vacuum / Cleaner

SPECIFICATIONS

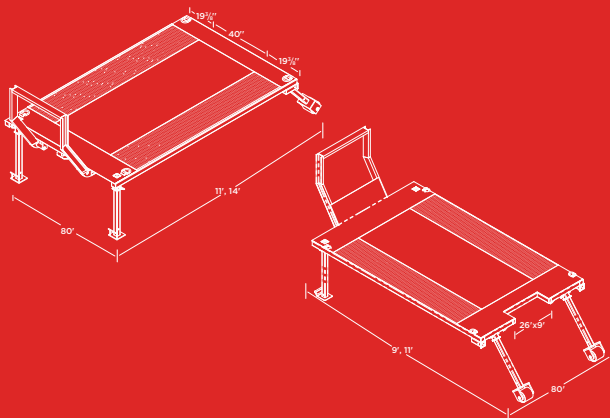

9' | 11' | 12' | 14' LENGTHS

MAXIMUM LOAD LIMIT

10,000LBS

ATTACHMENT POINTS

4 D-RINGS RATED AT 4080LBS EACH LOCATED IN CORNERS

SIDE DECK FLOOR

19" WIDE EXPANDED METAL 3/4"

CENTER FLOOR

WIDE DIAMOND SHEET 1/8"

LEGS

DETACH AND STOW

9' & 11' LENGTHS ONLY

26" WIDE X 9" REAR CUTOUT

Specifications are subject to change without notice. For warranty information on this or any other Switch-N-Go® product please refer switchngo.com/warranty.



MULCH MATE BODY



SWITCHNGO.COM



Features

- Designed for use with Mulch Mate® DS1000
- Retractable legs for off truck use and off season storage
- Curb Side Door for access to the front of the container
- High quality powder coating finish
- Available in 11' & 14' lengths

FOR PRICING & INFO , PLEASE VISIT

WWW.MULCHMATEUSA.COM



PARTNERSHIP WITH



TRUCK BODY OPTIONS

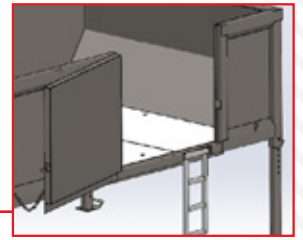
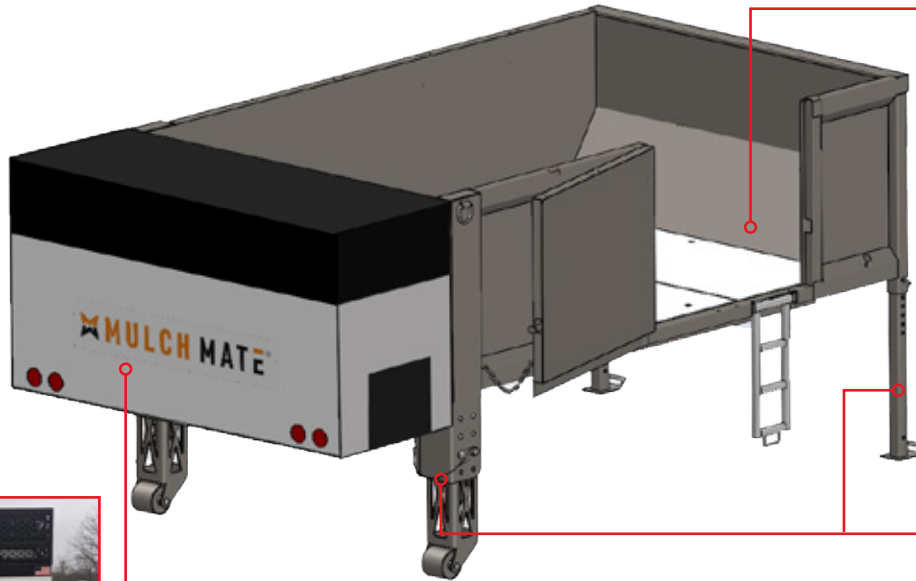

Curbside Door



Retractable Legs



Compatible with Mulch Mate DS1000

SPECIFICATIONS

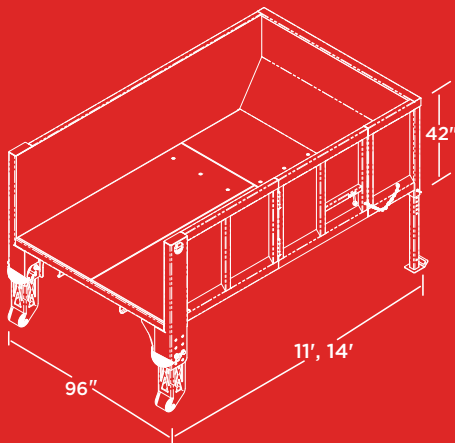

	11'	14'
FLOOR	10 GA	
SIDES	12 GA	
SIDE HEIGHT	42"	
LEGS	(4) RETRACTABLE LEGS	
CROSSMEMBERS	FORMED & INTEGRATED FOR ADDED STRENGTH	
CURB SIDE DOOR	52"W x 42"H W/ LATCHING MECHANISM & SAFETY CHAIN	
REAR POSTS	1/4" THICK FOR ADDED STRENGTH	
HOIST COMPATIBILITY	11'	14'

Specifications are subject to change without notice. For warranty information on this or any other Switch-N-Go® product please refer switchngo.com/warranty.



Interchangeable Truck Body System

STAINLESS STEEL DUMP BODY



SWITCHNGO.COM



Features

- Superior Corrosion Protection
- Double Acting Tailgate
- Manual Front Release
- Bottom Painted Black
- Available in 11' and 14' lengths



TO FIND A DEALER IN YOUR AREA

SWITCHNGO.COM/DEALER



TRUCK BODY FEATURES



Manual Front Release



Double Acting Tailgate



**Drop Down Sides
(optional)**

SPECIFICATIONS

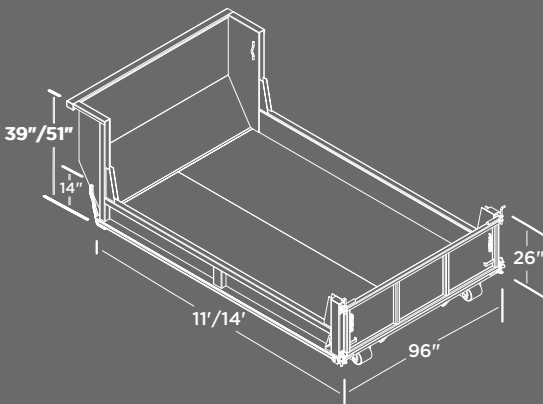

	11'	14'
FLOOR	10 GA 304 STAINLESS STEEL	
SIDES/FRONT/TAILGATE	10 GA 304 STAINLESS STEEL	
TAILGATE HEIGHT	26" HIGH	
SIDE HEIGHT	14" HIGH	
BULKHEAD	INSIDE HEIGHT 39" OR 51"	
BOARD POCKETS	6" HIGH	
D-RINGS	1 ON EACH CORNER	
OPTIONS	DROP DOWN SIDES (14' LENGTH SPLIT SIDES) BOLT ON 1/8" STAINLESS STEEL CAB SHIELD	
HOIST COMPATIBILITY	11'	14'

Specifications are subject to change without notice. For warranty information on this or any other Switch-N-Go® product please refer switchngo.com/warranty.



Interchangeable Truck Body System

SALT SPREADER BODY



SWITCHNGO.COM



Features

- Superior Weight Distribution as compared to non-specialized upfits
- 4.8 Cubic Yard 304 Stainless Steel V-Box
- 12" Angled Front Extension
- 9" Rear Cutout for Conveyor
- Sloped Front Design
- Retractable Legs for interchangeability & storage without removing the chute
- 10,000lb maximum load operation
- Expanded metal subframe floor to prevent material buildup

TO FIND A DEALER IN YOUR AREA

[SWITCHNGO.COM/DEALER](https://www.switchngo.com/dealer)



FEATURES



9" Rear Cutout for Conveyor



12" Angled Front Extension

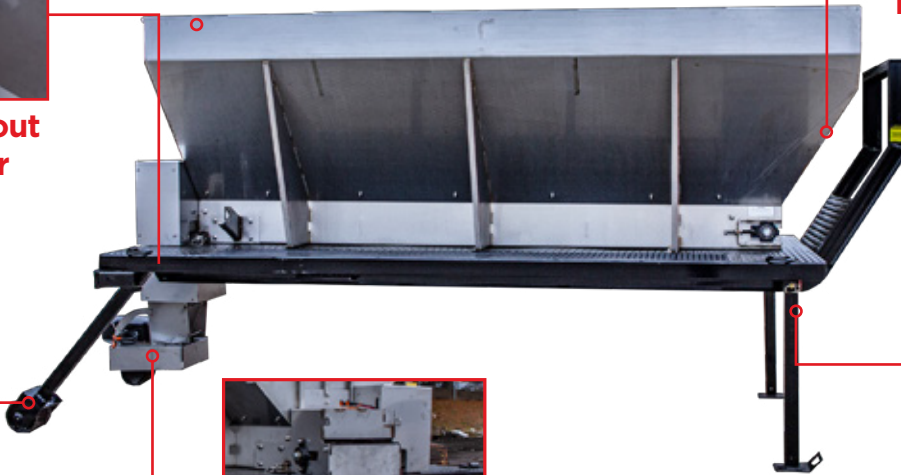

Detachable Ground Rollers



Electric Conveyor and Spinner



Retractable Legs

SPECIFICATIONS

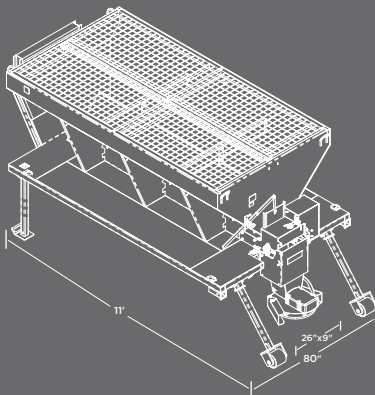

11' LENGTH ONLY

WORKING LOAD LIMIT	10,000LBS
SPREADER CAPACITY	4.8YD
ATTACHMENT POINTS	4 D-RINGS RATED AT 4080LBS
FLOOR	SIDE 19" WIDE EXPANDED METAL 3/4" CENTER 40" WIDE DIAMOND SHEET 1/8"
REAR CUTOUT	26" WIDE X 9" DEEP
LEGS	DETACH AND STOW
SPREADER CONVEYOR	ELECTRIC

Specifications are subject to change without notice. For warranty information on this or any other Switch-N-Go® product please refer switchngo.com/warranty.



Interchangeable Truck Body System

VAN BODY



SWITCHNGO.COM



Features

- Lightweight Design for Additional Payload
- Superior Corrosion Resistance
- Single Rear Roll-Up Door
- Fully Enclosed Unit for Cargo Protection
- Smooth Sides for Additional Advertising
- Available in 12', 13' & 15' lengths to be compatible with 11', 12' & 14' Switch-N-Go hoist systems.*

*Not compatible with S-Model

TO FIND A DEALER IN YOUR AREA

SWITCHNGO.COM/DEALER



TRUCK BODY FEATURES



Lockable Rear Roll-Up Door



Interior E-Track



Grab Handles



Bolt-on Aluminum Pullout Ladder

SPECIFICATIONS

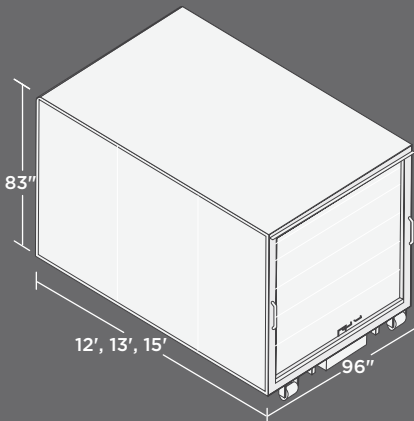

	12'	13'	15'
FLOOR	TONGUE & GROOVE EXTRUDED ALUMINUM		
REAR ROLL-UP DOOR	86"W x 77"H		
INTERIOR SIDES	1/2" PLYWOOD WITH E-TRACK		
SIDE HEIGHT	83"		
CROSSMEMBERS	12" ON CENTERS		
D-RINGS	(4) ON FLOOR		
HOIST COMPATIBILITY	11'	12'	14'

Specifications are subject to change without notice. For warranty information on this or any other Switch-N-Go® product please refer switchngo.com/warranty.



Interchangeable Truck Body System

ARBOR BODY



SWITCHNGO.COM



Features

- Fully enclosed container for cargo protection
- Smooth sides for advertising
- Coal tar epoxy corrosion resistant bed liner
- Tool & Ladder Boxes for additional storage
- Undercoated Floor and Toolboxes
- Lockable 30" high swing style tailgate
- Weather- and Debris-Resistant Lights & Wiring Harness
- Installed Lighting Kit
- Available in 12' & 15' lengths to be compatible with 11' & 14' Switch-N-Go® hoist systems*

*Not compatible with S-Model

TO FIND A DEALER IN YOUR AREA

SWITCHNGO.COM/DEALER



TRUCK BODY OPTIONS



Venting



Weather and Debris-Resistant Lights



Side Tool Box



Ladder Box

SPECIFICATIONS

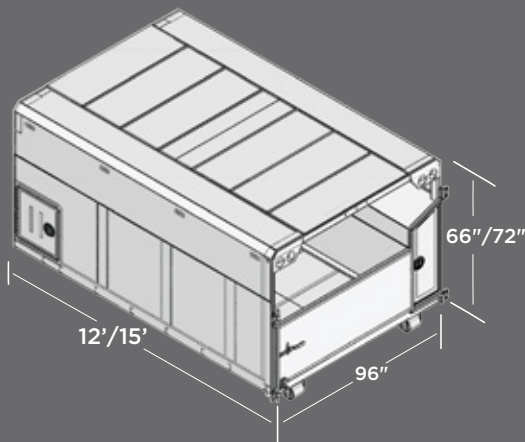

	12'	15'
FLOOR	10 GA GALVANNEAL	
TAILGATE	LOCKABLE 30" HIGH SWING STYLE	
ROOF	14 GA GALVANNEAL	
SIDES	12 GA GALVANNEAL	
SIDE HEIGHT	66" HIGH	72" HIGH
SIDE TOOL BOX	29"H x 26.5"W x 96" L	
LADDER BOX	38"H x 13"W x 117.5" L	
VENTING	(4) PER SIDE	
LIGHTING KIT	INSTALLED (REQUIRES FINISH WIRING)	
HOIST COMPATIBILITY	11'	14'

Specifications are subject to change without notice. For warranty information on this or any other Switch-N-Go® product please refer switchngo.com/warranty.



Interchangeable Truck Body System

HOIST SYSTEM



Body Hold Downs

Universal design to secure multiple body lengths* with one system
*Bodies must be system length or shorter

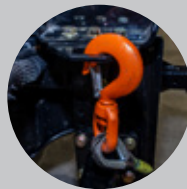

Hook Point

Integrated cable hook stowing on both sides of system

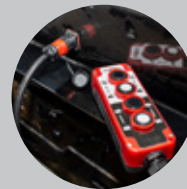

Pendant Control

Simple design for single-handed operation



Swivel Hook

Reduces cable stiffness for improved cable spooling and body attachment

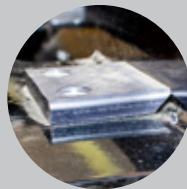

Slide Pads

Provide low friction body support and reduced wear on the system/body rails



Body Rollers

Single piece, self-greasing and bolt-on design for smooth rolling

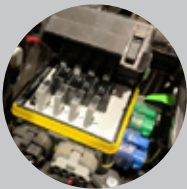

Electronics System

Fully enclosed and waterproof junction box with an IP 66 rating



V Roller

Poly material to reduce excessive wear and extends cable life



Pump Cover

Provides additional protection to the pump



Switchngo.com • 888-311-0867
607 Erie Street Saegertown, Pennsylvania 16433