



8GHT GLOBAL HIGH PERFORMANCE TRASH



Global Pump® High Performance Trash pumps are specifically designed to effectively handle a wide-range of liquids from water to sewage and sludge that can contain solids and other material.

Global Pump High Performance Trash pumps provide a dependable, highly efficient solution. The model 8GHT is capable of achieving maximum flows of 4,550 gpm (1,033 m³/h) and maximum total head of 261' (79.6 m) while handling solids up to 4" (101.6 mm) in diameter.

The standard 8GHT is powered by a water-cooled, 6-cylinder diesel engine. Alternative drives are available, including other diesel engines or electric motor options.

FEATURES

Global Pump's rugged, heavy duty pumps are engineered specifically for portable application

Non-return valve uses only a single moving part to allow full flow with minimal restriction

Standard engine control panel provides preset emergency shutdown protection and allows the addition of automatic level control

Fully guarded coupling

Pump casings are hydrostatically tested to 50 psig (345 kPa) above the peak casing design pressure

Highway trailer with integral fuel cell/chassis, lights, fenders, tie downs, lifting bail, front and rear jacks. Trailer brakes can be offered as required

OPTIONS

Available with a variety of priming systems, including Global's Auto Prime® automatic priming system (compressor-fed venturi priming) or a diaphragm priming system

Mechanical seal with glycol (biodegradable optional) quench allows the pump to start and run dry

Global Pump's Environmental Box separates and silences air exhaust and returns liquid to the pump suction.

Fuel cubes for extended run times and/or remote location as required

Sound attenuated enclosure options

Skid-mounted formats with tie downs, lifting bail, and fork pockets

Hose racks, accessory containers and other custom features available as required

Wide range of suction and discharge fittings including Global Pump's own "QD" Quick Disconnect fittings and accessories

SPECIFICATIONS

Connections	8" (200 mm) ANSI Flanges
Max Pump Speed	2,000 rpm
Max Flow	4,550 gpm (1,033 m ³ /h)
Max Head	261' (79.6 m)
Max Static Priming Lift	28' (8.5 m)
Temperature Limit	160° F (70° C)
Solids Handling Capability	4" (101.6 mm)
Max Casing Pressure	125 psig (862 kPa)
Fuel Cell	150 gallons (565 liters)
Dry Weight	6,300 lbs

PUMP MATERIAL

Casing	Cast Iron (CD4MCu is an option)
Impeller	Cast Iron (CD4MCu is an option)
Bearing Housing	Cast Iron
Bearing Lubrication	Grease
Shaft/Shaft Sleeve	Steel/FNC Treated Steel
Seal	Silicon Carbide on Silicon Carbide
Chassis/Fuel Cell	Steel
Non-Return Valve	Nitrile Fitted Cast Iron

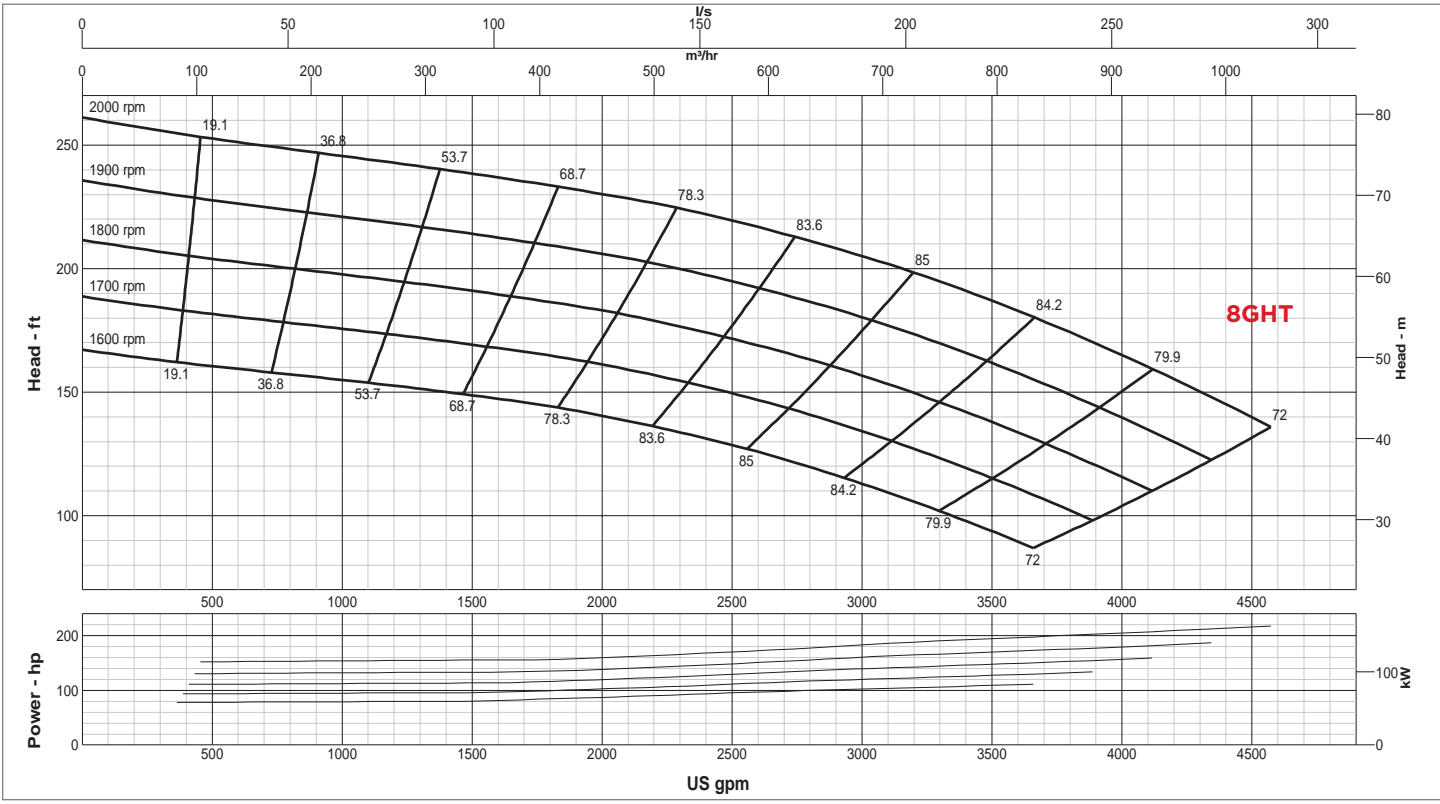
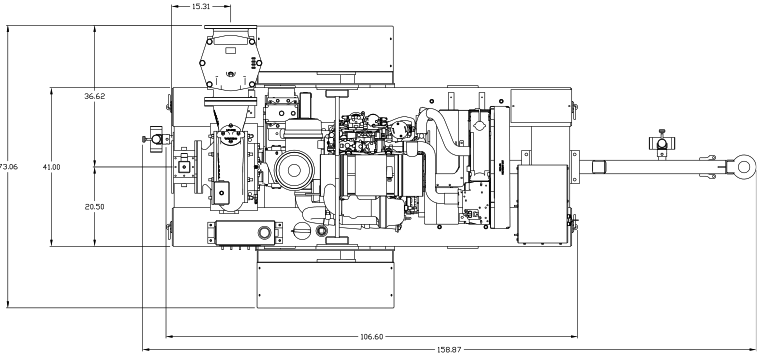
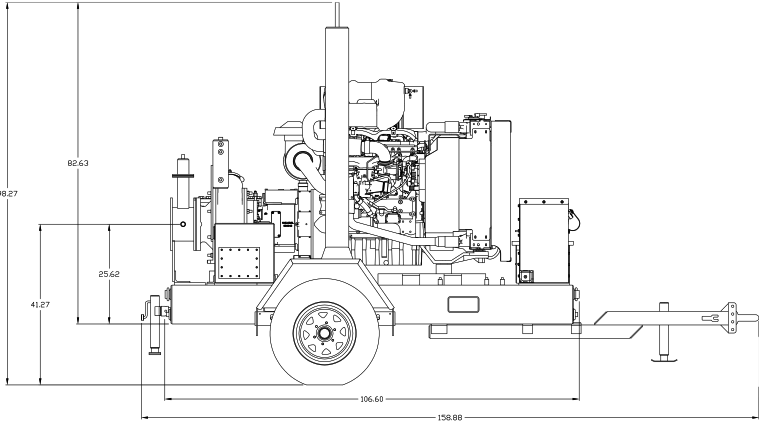

GLOBAL PUMP
 10162 East Coldwater Road, Davison, MI 48423
 Tel: 810.653.4828 Fax: 810.658.0632
1.866.360.PUMP www.globalpump.com

GLOBAL CONTROL BOX



ADVANCED PUMP CONTROL

A wide range of operating modes for both manual and auto operation to match the pumping requirements of the application.

DESCRIPTION
GENERAL
<ul style="list-style-type: none"> • Full Display • Fault Code Reader and Alarm Log • Service Alerts • Fuel Level Available • Alarm Horn • Monitor Suction & Discharge Pressure
AUTO START OPERATION MODES
<ul style="list-style-type: none"> • FLOATS (Single and Dual Float) • PRESSURE (Start, Stop and Maintain Pressure) • LEVEL (Start, Stop and Maintain Level) • INTEGRATED SCHEDULER (Run Days/Times)
AUTO THROTTLE OPERATION
<ul style="list-style-type: none"> • Warm Up Speed & Period • Prime Speed & Period • Operating Speed • Cool Down Speed & Period • Pressure and Level Maintain
FAILSAFE FLOAT BACKUP
<ul style="list-style-type: none"> • Float backup available in case of pressure or level transducer failure

PUMP CONTROL TECHNOLOGY

Controls, Incorporated brings its advanced engine control technology and reputation for durability to provide advanced pump control with simple and intuitive operation for Global Pump.

DURABILITY

The water tight IP67 rated display and control module is mounted in a NEMA 4X rated panel providing a two layer construction for maximum protection.

EASY-TO-READ DISPLAY

An advanced OLED display provides superior visibility in all lighting conditions while providing an extended temperature down to -40°C/-40°F.



Suction and discharge pressure monitoring is also available.

AUTO START OPERATION

A variety of auto start and auto throttle modes are available, providing a wide range of pump control options.

Auto Start/Stop

- Floats, Level, Pressure, Real-Time Clock Scheduler

Auto Throttle

- Warm Up, Prime, Operating and Cool Down Speeds
- Auto Throttle to Maintain Level or Pressure

Failsafe Float Backup

- Float backup for pressure and level applications

THROTTLE CONTROL

Minimum speed, maximum speed and rate of acceleration are selectable to assure the pump always operates in the correct speed range.

FAULT CODES

Engine alarm codes are displayed along with easy-to-read messages and corresponding yellow or red lamp illumination.

COMMUNICATIONS

Panel communications for simple integration with external devices, SCADA, remote monitoring and telemetry systems.

T4956 - C4.4 (TTA), AJ408 129.4 kW @ 2200 rpm



Engine Model:
C4.4

Curve: T 4956 Sheet 1
Issue: 1 Date: 17-Jul-2017

Caterpillar Inc.
©2017 Commercial in Confidence,
proprietary information of
Caterpillar Inc.

**Development Target -
May be Subject to Change**

Rating Standards:	ISO 14396: 2002	Fuel Types:	USA FED Off Highway	Europe Off Highway
Production Tolerance On Power Output:	+3%, -3%	Fuel Specification:	EPA Part 1065.703 ULSD	EU 2004/26/EC Stage 3B/4
Total Barometric Pressure (kPa):	100	Density (kg/l @ 15°C):	0.840 - 0.865	0.833 - 0.837
Vapour Pressure (kPa):	1	Viscosity (mm²/s @ 40°C):	2.0 - 3.2	2.3 - 3.3
Air Inlet Temperature (°C):	25	Sulphur Content (% mass):	0.0007 - 0.0015	0.001 max
		Cetane No:	40 - 50	

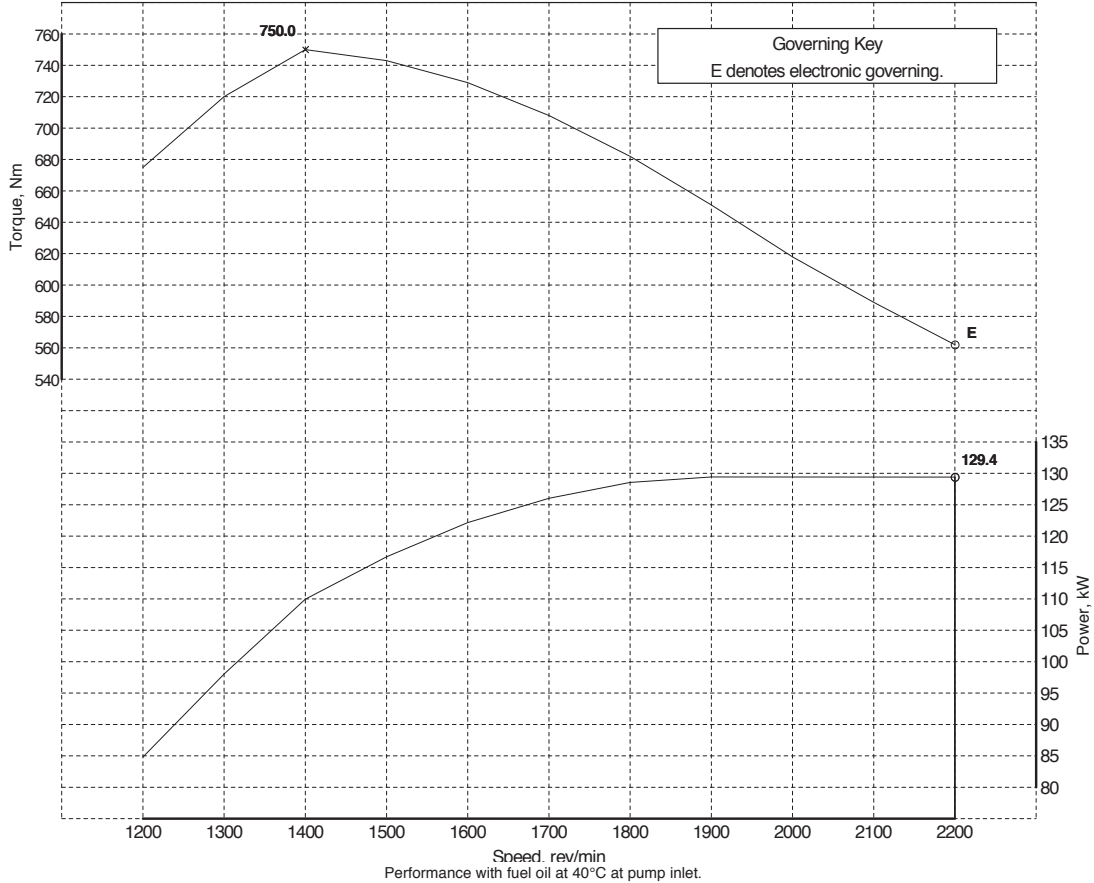

Notes:
1. For duty cycle refer to the C rating definition(s) in the Caterpillar Industrial Engine Ratings Guide (LECH3874).

Exhaust Quality Standard
Smoke:
US EPA 40 CFR Part 1039.105.

Emissions:
US EPA 40 CFR Part 1039 Tier 4 Final.
CARB 13CCR Section 2423 Tier 4 Final
EU NRM 97/68/EC Stage 5
Japan MOC/MLIT non-road Step 4 Final.
South Korea MOE non-road Tier 4 Final.
Switzerland FOEN non-road Stage IV

Certification Refs (Rated Speeds)

Auxiliaries fitted to engine:
Alternator - off load.
Fan - not fitted.

Power Standard
UN/ECE R120

Certification Refs (Rated Speeds)

Approved by:
J.L. Soilleux
(Program Manager)
J.L. Soilleux
Date 12-Jun-2017

Accepted by:
R. Cooper
(Product Engineering Manager)
R. Cooper
Date 19-May-2017

Issued by:
S.M. Ottaway
(Legislation Engineer)
S.M. Ottaway

Rating Curves Data Sheet

Curve T 4956 Sheet 2

Note1: Unless otherwise specified, all stated data is for maximum rated speed and 100% load.

General Data

Engine Model:	1204J-E44TTA
Number Of Cylinders:	4
Bore (mm):	105.0
Stroke (mm):	127.0
Configuration:	Vertical In Line
Displacement (litres):	4.4
Aspiration:	Turbocharged
Compression Ratio:	16.5 : 1
Combustion Bowl:	

Fuel System

Fuel Pump Model:	Denso
Injection Timing (°BTDC) - Static:	
- Dynamic (needle lift pick-up):	
Lift Pump Pressure (Out) (kPa):	
Fuel Pump Pressure (In) (kPa):	
Fuel Filter Max Particle Size (micron):	3 - 5 (ISO)
Fuel Return System Type:	Return to Tank

Lubrication System

Lubricating Oil Specification: See Engine Specification Manual

Exhaust System

Exhaust Flow (kg/min):
Exhaust Temperature (°C):

Cold Start Capability

Unaided Start Limit (°C):	-10
Aided Start Limit (°C):	-25
Start Aid (Optional):	Glowplugs fitted as standard
Minimum Cranking Speed (rev/min) - unaided:	130
- aided:	100

Cooling System

Heat Rejected @ Rated Speed (kW):	
Heat Rejected @ Peak Torque (kW):	
Coolant Flow (litres/min):	
Thermostat - Start To Open (°C):	82
Thermostat - Fully Open (°C):	93
Recommended Cap Pressure (kPa):	100
Max Top Tank Pressure (kPa):	100 *
* See General Installation Manual	

Air System

Engine Air Flow (kg/min):
Induction Manifold Pressure (kPa):

Charge Air Cooler System

Charge Air Cooling System:	Air-to-Air
Max Total Pressure Drop inc Pipes (kPa):	10.0
Charge Air Cooler Heat Rejection (kW):	
Manifold Charge Air Temperature (°C):	55.0

Turbocharger

Turbocharger Type:
Maximum Altitude (m): 3000

Performance Data

Friction Power @ Rated Speed (kW):
Friction Power @ Peak Torque (kW):
Torque @ 800 rev/min (Nm): Not applicable

For further performance data see table below.

Performance Data			Rating Standard: ISO 14396: 2002			Further Notes:
Speed (rev/min)	Torque (Nm)	Power (kW)	Max Exhaust Back Pressure (kPa)	Max Inlet Restriction (kPa)	Governing Categories (key on sht 1)	
2200	562	129.4	30.8	6.5	E	The exhaust pressure and inlet restriction values are appropriate for certification tests Configurable Rated Speed 1900 - 2200rpm See PSR 13006 for further details
2100	589	129.4				
2000	618	129.4				
1900	651	129.4				
1800	682	128.6				
1700	708	126.0				
1600	729	122.1				
1500	743	116.7				
1400	750	110.0				
1300	720	98.0				
1200	675	84.8				

Internal References

Curve Issue No: 1 DCP Number(s):
Curve Issue Date : 17-Jul-2017

TAN Number:
FIE EDR Number