



2501 Griffin Ave - Selma - AL 36701 - USA - Phone 800-363-6096

Contract: 23-04-0713 Virginia Sheriffs' Association

Bid: 2022-2023 Heavy Equipment

Group: Rear Mounted Boom Mower

Item Number: 344 Rear Mounted Boom

Build Sheet



REAR-MOUNTED BOOM MOWER SERIES

MODEL	RMB1445-1
Minimum Tractor PTO HP/Weight	See Head Selection Chart Next Page - Varies Based on Head Choice
Tractor PTO	540 RPM
Machine Weight with Flail	1,220 lb.
Hydraulic System	Totally Independent (Self-Contained) Hyd. System, Pump Powered by Tractor PTO
Hydraulic Remotes Required	None Required
Hydraulic Oil Required	21.75 gal.
Attachment Method	Cat 1/2, 3-Point Mount
Controls	Cable-Controlled Quick Detach (QD) Stan-
Maximum Reach, Horizontal (A)	14' 1"
Maximum Height, Horizontal (B)	13' 2"
Maximum Height, Horizontal (C)	13' 5"
Maximum Height, Vertical (D)	13' 9"
Maximum Depth (E), 45°	5' 4"
Lightbar Kit	Standard

NOTICE: RMB Series mowers are to be used only on tractors equipped with cabs. For rotary mower heads, protective screen material must be installed.

HOW TO ORDER: To receive a complete cutter, for RMB models you must include a basic unit and the appropriate head option(s) from Group 2, 3 or 4 in the ordering section. For the PT5 model, make your base unit selection, which comes standard with a sickle bar head. No head selection is necessary. Additional equipment may be added to your order by making your selection from the Options list.

Freight NOT included in list price

NOTE: ALL UNITS ARE SHIPPED WITH NO OIL INSTALLED.

Additional Choices Available on Options Pages

HEAD SELECTION CHART

FLAIL HEAD	RMB1445-1
Minimum Tractor PTO HP/	45 HP / 4,410 lb.
Rotor/Knife	Super Cut/Universal
Typical Application	Grass, Light Brush
Cutting Capacity	1" Diameter
Cutting Width	39"

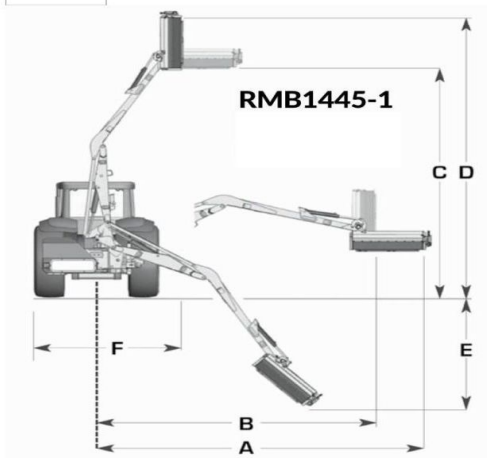

Quoted Build Details

RMB1445-1	RMB 1445 Rear-Mounted Boom with Quick Detach Cable Controls and Light Kit
50071904	Supercut Compact Flailhead, Universal Knives, 39" Wide Cut, 1" Capacity