



ENGINE

Model	FPT F5B FL413 E*B002
Emissions Certification	Tier 4 Final
Type	Diesel, Turbo – Direct Injection
Cylinders	4
Bore/Stroke	3.9 x 4.3 in (99 x 110 mm)
Displacement	207 in ³ (3.4 L)
Fuel injection	Direct
Fuel	#2 Diesel
Fuel filter:	
Pre-filter	Beta (30) = 200/spin-on
Main filter	Beta (4) = 20/spin-on
Air intake	Turbocharged w/ waste gate and external cooled EGR
Exhaust aftertreatment	Selective Catalytic Reduction (SCR)
Cooling	Liquid
Engine speeds	RPM
High idle – no load	2500 +/- 25
Rated – full load	2500
Low idle	1150 +/- 25
Horsepower @ 2500 RPM – SAE J1349:	
Gross	90 hp (67 kW)
Net	84 hp (63 kW)
Peak torque @ 1400 RPM	282 lb-ft (383 N-m)
Radiator:	
Core type	Aluminum bar and plate
Core size area	319 in ² (0.206 m ²)
Rows of tubes x columns	21
Cap pressure	16 +/- 2 psi (1.10 +/- 0.14 bar)
Fan:	
Diameter	22 in (560 mm)
Ratio	0.96:1 standard, 1.1:1 high-flow
Water pump:	
Style	Centrifugal
Flow	47.8 gpm (181 L/min)
Engine lubrication pump:	
Rotor pump w/ deep sump pan, plate cooler and pressurized under-piston nozzles	
Pump operating angle ratings:	
Side to side	45°
Bucket up	35°
Bucket Down	45°

LIFT GEOMETRY

Radial Lift

DRIVETRAIN

Drive pump controls	Servo-assist mechanical
Pump to engine ratio	1:1
Displacement	2.81 in ³ (46 cm ³)
Flow @ rated engine RPM:	
@ 97% efficiency	29.4 gpm (111 L/min)
Charge pressure	360 psi (24.5 bar)
System relief pressure	5,220 psi (360 bar)
Drive pump controls	Electro-hydraulic
Pump to engine ratio	1:1
Displacement	2.75 in ³ (45 cm ³)
Flow @ rated engine RPM:	
@ 97% efficiency	28.8 gpm (109 L/min)
Charge pressure	362 psi (25.0 bar)
System relief pressure	5,220 psi (360 bar)
Drive motors:	
Max. displacement	3.10 in ³ (50.9 cm ³)
Displacement – optional:	
High speed	2.02 in ³ (33.1 cm ³)
Motor RPM @ high idle and 97% efficiency:	
2-speed	156
Motor torque @ max. displacement and relief pressure, calculated @ 5,220 psi (360 bar):	4,654 lb-ft (6 310 N-m)
Travel speed:	
Low range	5.1 mph (8.2 kph)
High range	8.0 mph (12.9 kph)
Final drive:	
Planetary gearbox w/ 2-speed motor	
Tractive effort	7,414 lb (3 370 kg)
Parking brake:	
Type	Spring-applied, hydraulic release multiple disc.
Engagement	Depress on/off brake button on handle or instrument panel, raise seat bar, get off seat or stop engine.

ELECTRICAL

Alternator	160 amp
Starter	4.29 hp (3.2 kW)
Battery	12-volt low-maintenance 1,000 cold-cranking amps @ 0° F (-18° C°)

OPERATOR ENVIRONMENT

ROPS/FOPS Level 1 canopy w/ side screens; Keyed start ignition; AM/FM radio w/ 2 speakers/Bluetooth; Keyless start ignition; Tilt ROPS/FOPS; Rear window w/ emergency escape; Suspension Seat, vinyl w/ 2 in (51 mm) retractable 3 point lap seat belt; Hand and Foot throttle; Alarm package – back-up and horn; Rearview mirror; Headliner; Dome Light; Top window; Cup holder; 12V Power plug socket; Foot rest; Seat Pocket; Padded seat bar w/ integral armrests; Loader control lockout system; Electric parking brake control; Operator's

compartment floor cleanout; Proportional auxiliary hydraulic control – on joystick; Advanced Instrument Cluster w/ digital hour meter, tachometer, Fuel level LCD bar graph w/ alarm, diagnostic features and security lockout.

Warning lights with alarms:

Engine coolant temperature; Engine oil pressure; Engine malfunction; Hydraulic charge pressure; Hydraulic filter restriction; Hydraulic oil temperature: Critical system stop, Engine system, Hydraulic system, Electrical and diagnostic system.

Warning alarms:

Battery voltage – plus display; Oil service.

Indicator light:

Engine preheat; Parking brake; Seat bar reminder.

OPERATING WEIGHT

Unit equipped w/ open cab; 165 lb operator; 78 in Dirt & Foundry bucket; full of fuel:

	10,000 lb (4 536 kg)
Shipping weight	9,656 lb (4 380 kg)

Add-on weights:

Side cab glass	47 lb (21.3 kg)
Polycarbonate cab door	75 lb (34.0 kg)
Glass cab door w/ wiper	75 lb (34.0 kg)
Suspension seat	22 lb (10.0 kg)
Additional counterweight	600 lb (273.0 kg)

HYDRAULICS

Implement pump type	Gear
Displacement:	
Standard aux.	2.23 in ³ (36.6 cm ³)
High-flow aux.	1.24 in ³ (20.4 cm ³)
Standard flow @ rated engine RPM:	
@ 100% efficiency	24.2 gpm (91.5 L/min)
Optional high-flow @ rated engine RPM:	
@ 100% efficiency	37.6 gpm (142.5 L/min)
Enhanced high-flow @ rated engine RPM:	
@ 100% efficiency	35.0 gpm (132.5 L/min)
Loader control valve:	
Type	3 spool/open center/series - series
Relief pressure	3,046 psi (210 bar)
Port relief pressures:	
Loader raise	3,263 psi (225 bar)
Bucket curl	3,770 psi (260 bar)
Bucket dump	1,160 psi (80 bar)
Hydraulic lines:	
Tubing	37° JIC Flare
Loop hoses	SAE 100 R19
Hydraulic oil cooler:	
Number of fins	10 per inch (3.94 per cm)
Number of tube rows x columns	9 bar/plate
Area	130.7 in ² (843.2 cm ²)
Hydraulic filter	Beta (4) = 75/spin-on

HYDRAULICS CONT.

Lift cylinders:	
Bore diameter	2.75 in (69.85 mm)
Rod diameter	1.75 in (44.5 mm)
Stroke	32.20 in (817.9 mm)
Closed length	45.60 in (1 158.0 mm)
Bucket cylinders:	
Bore diameter	3.0 in (76.2 mm)
Rod diameter	1.5 in (38.1 mm)
Stroke	16.4 in (410.0 mm)
Closed length	24.0 in (610.0 mm)

SERVICE CAPACITIES

Fuel Tank	25.5 gal (96.5 L)
Engine oil w/ filter	8.9 qt (8.5 L)
Hydraulic system:	
Reservoir	6.0 gal (22.7 L)
Total	11.9 gal (45.4 L)
Diesel Exhaust Fluid (DEF) Tank	2.8 gal (10.7 L)

PERFORMANCE SPECS

Rated operating capacity – ROC*:	
35% of tipping load	2,380 lb (1 079 kg)
50% of tipping load	3,400 lb (1 542 kg)
w/ additional counterweight	3,600 lb (1 633 kg)
Tipping load*	6,800 lb (3 084 kg)
Breakout forces @ 3,150 psi (217 bar)*:	
Bucket cylinders	8,700 lb (38.7 kN)
Lift cylinders – hydraulic limit	7,760 lb (34.5 kN)
Cycle times:	
Raise	4.4 sec
Lower	2.6 sec
Dump	2.6 sec
Roll back	2.0 sec

NOTE: *Measured using 78 in (1.98 m) foundry/ excavating bucket.

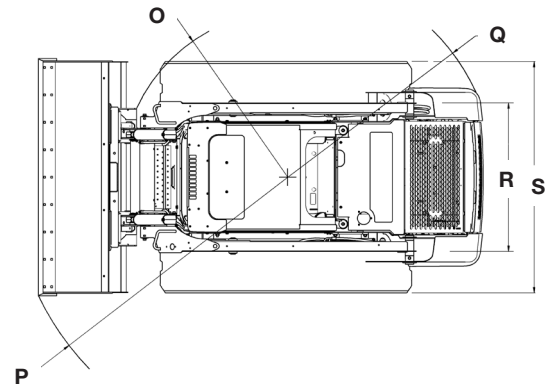
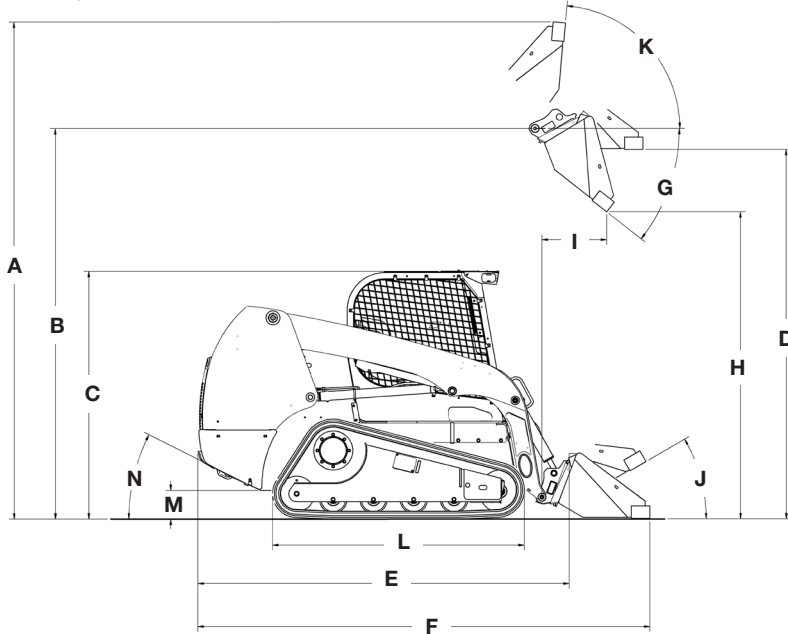

Line drawings are for illustrative purpose only and may not be exact representation of unit.

DIMENSIONS

A. Overall operating height:	
with foundry/excavating bucket	157.2 in (3.99 m)
with heavy-duty dirt bucket	161.4 in (4.10 m)
with low profile extended bucket	166.2 in (4.22 m)
Height to:	
B. Bucket hinge pin	126.7 in (3.22 m)
C. Top of ROPS	80.4 in (2.04 m)
D. Bottom of level bucket, fully raised	118.7 in (3.02 m)
Overall length:	
E. without attachment with coupler	118.2 in (3.00 m)
F. with foundry/excavating bucket on ground	142.6 in (3.62 m)
with heavy-duty bucket	146.8 in (3.73 m)
with low profile extended bucket	151.7 in (3.85 m)
G. Maximum dump angle	38.1°
H. Dump height:	
with foundry/excavating bucket	102.2 in (2.59 m) @ 38.1°
with low profile bucket	99.5 in (2.53 m) @ 38.1°
I. Dump reach at maximum height with heavy-duty bucket	24.7 in (0.63 m) @ 38.1°
Maximum attachment rollback:	
J. Bucket on ground	30.6°
K. Bucket at full height	100.0°
L. Track on ground	64.5 in (1.64 m)
M. Ground clearance – bottom of belly pan	9.5 in (0.24 m)
N. Angle of departure	32.0°
Clearance circle:	
O. without bucket	55.8 in (1.42 m)
P. with 78 in (1.98 m) foundry/excavating bucket in carry position	86.2 in (2.19 m)
with 78 in (1.98 m) heavy-duty bucket on ground	90.0 in (2.29 m)
with 78 in (1.98 m) extended low profile on ground	94.4 in (2.40 m)
Q. Clearance circle rear	68.6 in (1.74 m)
R. Track gauge	58.6 in (1.49 m)
S. Over the track width	76.5 in (1.94 m)

TRACK SELECTION

Type	Area	Ground Pressure	Width to Outside Track
17.7 in (450 mm)	2,286 in ² (1.475 m ²)	4.2 psi (29 kPa)	76 in (1.93 m)

OPTIONAL BUCKETS

Type	Width	Weight	Heaped Capacity
Dirt & Foundry	72 in (1.83 m)	420 lb (190 kg)	16.2 ft ³ (0.46 m ³)
	78 in (1.98 m)	440 lb (200 kg)	17.7 ft ³ (0.50 m ³)
Low Profile	72 in (1.83 m)	480 lb (218 kg)	14.8 ft ³ (0.42 m ³)
Low Profile Extended	72 in (1.83 m)	510 lb (232 kg)	17.7 ft ³ (0.50 m ³)
	78 in (1.98 m)	540 lb (245 kg)	19.1 ft ³ (0.54 m ³)
	84 in (2.13 m)	575 lb (262 kg)	20.5 ft ³ (0.58 m ³)
Light Material	72 in (1.83 m)	475 lb (216 kg)	23.3 ft ³ (0.66 m ³)
	84 in (2.13 m)	540 lb (245 kg)	27.5 ft ³ (0.78 m ³)
Manure & Slurry	72 in (1.83 m)	480 lb (218 kg)	19.1 ft ³ (0.54 m ³)
Heavy-Duty	72 in (1.83 m)	510 lb (230 kg)	14.1 ft ³ (0.40 m ³)
	78 in (1.98 m)	530 lb (240 kg)	15.5 ft ³ (0.44 m ³)
	84 in (2.13 m)	550 lb (250 kg)	17.0 ft ³ (0.48 m ³)
Heavy-Duty Extended with SmartFit Teeth	72 in (1.83 m)	667 lb (303 kg)	17.4 ft ³ (0.49 m ³)
	78 in (1.98 m)	697 lb (316 kg)	18.9 ft ³ (0.54 m ³)
	84 in (2.13 m)	728 lb (330 kg)	20.5 ft ³ (0.58 m ³)

STANDARD EQUIPMENT

OPERATOR ENVIRONMENT

See page 1

ENGINE

FPT F5H FL463 A*F001
 207 CID (3.4 L) Turbo
 Tier 4 Final Certified
 Selective Catalytic Reduction (SCR)
 Charged Air Cooler (CAC)
 High Pressure Common Rail (HPCR)
 fuel injection
 Horsepower:
 Gross: 90 hp (67 kW)
 Net: 84 hp (63 kW)
 Peak torque: 282 lb-ft (383 N·m)
 160 amp alternator
 Dual element air cleaner
 Organic Acid Technology (OAT)
 Anti-freeze solution to -34° F
 Fuel tank - 25.5 gal (U.S.)
 Over and under radiator and oil cooler
 3-stack after cooler/radiator/oil
 cooler configuration
 Glow plugs
 Integral engine oil cooler
 Fuel filter with water trap
 1,000 CCA 12V battery
 Master electrical disconnect
 Jump Start Terminal

DRIVETRAIN

2-speed hydrostatic four wheel drive
 SAHR disc parking brake

HYDRAULICS

Auxiliary hydraulics:
 @ 3,050 psi (210 bar) – 24.2 gpm
 (91.5 L/min)
 6 micron oil filtration system
 3-spool loader control valve
 Auxiliary hydraulic disconnects, ISO
 flat-face – connect-under-pressure
 with case drain
 Hydraulic circuit pedal lock
 Auxiliary function lockout override
 Loader lift lockout override
 Heavy-duty hydraulic oil cooler
 Loader arm float position
 Loader function lockout system

LOADER

Heavy Duty Hydraulic attachment coupler
 Radial lift geometry
 Loader lift arm support strut
 SAE operating load: 3,400 lbs
 Tipping load: 6,800 lbs

TRACKS

Rubber Tracks

OTHER STANDARD FEATURES

Halogen lights - 2 front, 2 side, 2 rear flood
 Pre-wired for rotating beacon
 Lockable service access hood
 Single-point daily servicing
 Rear tail lights
 Remote oil drain
 Remote oil and fuel filters
 Block heater
 Debris ingress sealing
 Mounting points for add-on counterweights

OPTIONAL EQUIPMENT

OPERATOR ENVIRONMENT

Enclosed cab:
Fully sealed and pressurized – FSP
Glass door with wiper and washer
Sliding side windows – removable
Ventilation system with integrated heater
Heater and air conditioner
AM/FM Bluetooth radio with 2 speakers and USB port
Keyless start ignition
8 in Color LCD Display
Economy Mode (auto idle shutdown)
Auto Engine Protection Shutdown
Electro-hydraulic controls:
For drive/steering, loader functions
Switchable between H and ISO patterns
Adjustable sensitivity of controls
Mechanical hand controls
Hand and foot controls:
Hand controls the loader drive function and foot controls the bucket and boom
Deluxe cloth air suspension seat w/ heater and lumbar support
Open cab interior trim package
Demolition cab door with polycarbonate
FOPS Level 2
Ignition Timeout
Machine Settings User Access Levels
Operator Security Codes

HYDRAULICS

High-flow auxiliary hydraulics – combined:
@ 3,050 psi (210 bar) – 37.6 gpm
(142.5 L/min)
Enhanced High-flow auxiliary hydraulics – EHF:
@ 4,000 psi (276 bar) – 35.0 gpm
(132.5 L/min)
Second auxiliary hydraulics
Hydraulic one-way self-leveling
Ride control

LOADER

Auxiliary front electric control
Manual attachment coupler

DRIVETRAIN

Creep Speed Mode

OTHER

Language decals
Factory-installed tires – see page 3
Buckets – see page 3
Bolt-on bucket cutting edges
Bolt-on heavy-duty bucket spill guard
Special paint
Offsite service arrangement
Telematics

FACTORY SUPPLIED ATTACHMENTS

Add-on counterweights
Road lights
Rotating beacon
Four-corner LED strobe
48 in (1.22 m) pallet forks

SERVICE PARTS

3 inch (76.2 mm) retractable seat belt
Bolt-on heavy-duty bucket teeth

CaseCE.com

©2020 CNH Industrial America LLC. All rights reserved. CASE is a trademark registered in the United States and many other countries, owned by or licensed to CNH Industrial N.V., its subsidiaries or affiliates. CNH Industrial Capital is a trademark in the United States and many other countries, owned by or licensed to CNH Industrial N.V., its subsidiaries or affiliates. Printed in U.S.A. Contains 10% post-consumer fiber.

IMPORTANT: CASE Construction Equipment Inc. reserves the right to change these specifications without notice and without incurring any obligation relating to such change. Availability of some models and equipment builds vary according to the country in which the equipment is used. The illustrations and text may include optional equipment and accessories and may not include all standard equipment. Your CASE dealer/distributor will be able to give you details of the products and their specifications available in your area.



CASE Construction Equipment is biodiesel-friendly. NOTE: All engines meet current EPA emissions regulations. All specifications are stated in accordance with SAE Standards or Recommended Practices, where applicable.



Always read the Operator's Manual before operating any equipment. Inspect equipment before using it, and be sure it is operating properly. Follow the product safety signs and use any safety features provided.

Form No. CCE202001TR340B
Replaces Form No. CCE201911TR340B

TR340B

4 of 4