

**SYSTEM DESCRIPTION:**

The RS-3 is a loader mounted to a chassis with a short wheel base. From the upper cab, the operator can drive the RS-3 and load waste into a separate haul truck. Most loading operations do not require outriggers (see load chart).

**CHASSIS REQUIREMENTS:**

Because of the unique nature of this unit, there are very specific chassis requirements. Please contact Petersen for a complete list.

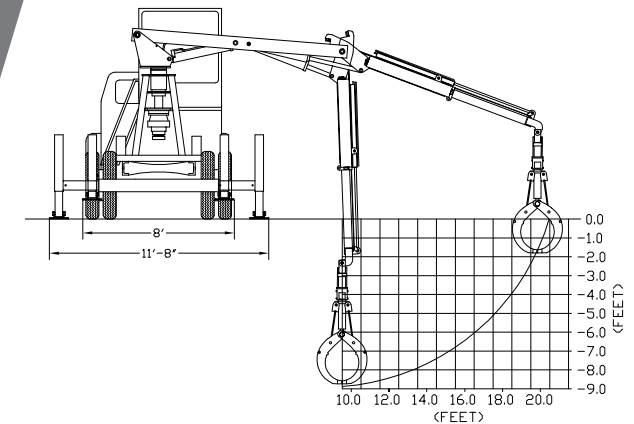

**CONTROL OPTIONS:**

**Single Electronic Joystick**

A single electronic joystick operates loader functions. These controls are also fully proportional and have preprogrammed ramp rates to reduce wear on loader.

**Dual Mechanical Joysticks**

Two mechanical joysticks operate loader functions. These controls are fully proportional; allowing for minute adjustments. Joysticks are connected to valve banks via mechanical linkages.



SCAN TO  
LEARN MORE



4000 SR 60 West  
Lake Wales, FL 33859  
**1.800.930.LOAD (5623)**



**PETERSENIND.COM**  
Contact Us Today To Learn More



**For NCSA Contract Purchases:**  
 Please send P.O. to Amick & NCSA including:  
 Contract #, Spec #, Contact Info, & Fed. Tax ID #  
 NCSA: kmitman@ncsheriffs.net  
[LINK: NCSA Terms & Conditions](#)

**CONTRACT #**  
**22-06-0426R**

Description		Contract Price
<b>PETERSEN OPTIONS</b>		
All Models	REAR VIEW CAMERA	\$ 1,638.00
All Models	FRONT MOUNT STROBES, AMBER	\$ 786.00
All Models	LED FLASHERS IN REAR CORNER BODY POST	\$ 473.00
All Models	WORK LIGHTS: SET OF 2, 1EA SIDE OF BOOM	\$ 445.00
TL-3	2026 HDX, 20' 26 YDS HARDOX TRASH BODY - ILO 24YD BASE MODEL	\$ 980.00
TL-3	2030 HDX, 20' 30 YDS HARDOX TRASH BODY - ILO 24YD BASE MODEL	\$ 1,495.00
TL-3	2240 XDX, 22' 40 YDS HARDOX TRASH BODY- ILO 24YD BASE MODEL	\$ 10,471.00
AL-1	2445 XDX 24' X 45 YDS - ILO 40YD BASE MODEL	\$ 6,056.00
AL-1	2450 XDX 24' X 50 YDS - ILO 40YD BASE MODEL	\$ 6,617.00
DL-3	2245 MHX 22' X 45 YDS TRASH BODY - ILO 40YD BASE MODEL	\$ 545.00
DL-3	2450 MHX 24' X 50 YDS TRASH BODY - ILO 40YD BASE MODEL	\$ 6,939.00
TT-2	10,000 LBS. TANDEM AXLE UPGRADE	\$ 5,632.00
TT-2	HYDRAULIC JACK STAND UPGRADE	\$ 2,654.00

*NOTE: OPTIONS PRICING DISCOUNTED BY 6% PER CONTRACT*

*NOTE: ADDITIONAL OPTIONS AVAILABLE UPON REQUEST.*

**DATE:** 4/14/2022

**ADDITIONAL OPTIONS:** Prices shown in "additional options available" section are not included in the "Total" price and do not include taxes.

**TAXES:** Unless itemized above, prices do not include local, state or federal taxes.

**MOTOR VEHICLE TAXES:** AECl no longer collects SC "IMF" or NC "Highway Use Tax". Either the chassis dealer or the DMV will collect motor vehicle tax/fees when registering vehicle.

**PAYMENT TERMS:** Payment is due PRIOR to delivery. When ample credit has been extended to customer, payment is due within 30 Days of invoice.

**TITLEWORK / MCO:** Allow 5-10 business days after receipt of payment to process Title or Manufacturer's Certificate of Origin (MCO).

**QUOTE EXPIRATION:** Pricing is honored for 30 days from date quoted, barring extenuating circumstances such as, but not limited to, volatile markets, factory price increases, etc. AECl makes every effort to give as much notice as possible in such instances.

**DELIVERY ESTIMATES:** ETA's are based on production schedules at the time of quote and are subject to changes in truck or body production schedules as well other factors such as transportation delays, etc.

**WEIGHT RESTRICTIONS:** Operating overweight equipment can result in fines, damage to equipment or injury to operators. AECl makes every effort to quote equipment meeting local, state & federal weight regulations. Nevertheless, it is up to the end user to familiarize themselves with all applicable weight laws and avoid exceeding legal weight limits, regardless of truck's GVWR.

**CHASSIS DEALERS:** Please ensure chassis specs meet body manufacturer's minimum requirements, which are supplied upon request. Deviations may result in additional charges, for which the truck dealer will be responsible.

**CHASSIS DEALER PAYMENT TERMS:** Payment term begins when truck is delivered to customer or truck dealer for PDI, whichever is first. Payments received later than 15 DAYS are subject to penalty of 5% APR, calculated on a daily basis. ANY EXCEPTIONS must be agreed to writing prior to order.

**COOPERATIVE PURCHASING CONTRACTS:** Cooperative purchasing contract such as NCSA, Sourcwell, etc. are a tool which satisfies the competitive bidding requirements for some municipalities. Amick Equipment (or its Body Manufacturer) are approved vendors on several contracts, authorized to offer awarded equipment according to each contract's terms and conditions. If a contract award included both body and chassis, then that contract clearly satisfies the bidding requirements for both body and chassis. Some of Amick's contracts were awarded for the body portion only. Upon request, Amick may offer a compatible chassis from another qualified contract holder or may offer a non-contract option.. Unless explicitly stated, customers shall not assume that any of the equipment quoted are being offered under a purchasing contract. It is up the purchaser to determine whether purchasing any items - both explicitly listed on the