



DESIGNED TO IMPROVE YOUR BOTTOM LINE

eco **E** **SERIES**

eco **E** **SERIES**

**THE MOST PRODUCTIVE
COMPACTOR ON THE MARKET**

Unique design

Twin drums Fewer passes, smooth and dense surface

Rigid frame Best crushing force

Crushing teeth Size, shape and number optimized to achieve maximum compaction

TANA ProTrack® To minimize downtime and reduce cost



Highest Compaction Results
GUARANTEED!

TANA

North America

From Waste to Value®

HOW WE GUARANTEE IT

BENEFITS OF TANA COMPACTORS

Improves profits through increased revenues and / or reduced expenses

- Greatly extends the life of the landfill
- Improves all vehicle cycle time in and around tipping area
- Reduces amount of lechate created
- Reduces landslides and cave-ins
- 40-60% less cover soil required because of even surface
- Greatly reduces risk of fire
- Reduced chassis damage to all vehicles on site - smooth compacted surface

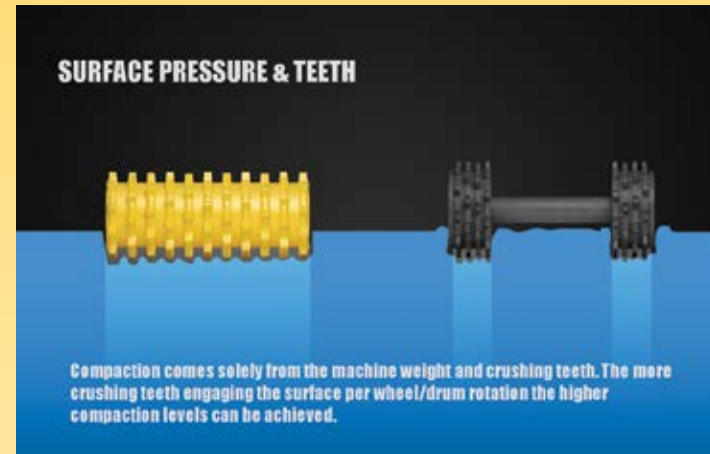

TWIN DRUMS PROVIDE FULL WIDTH

Compaction and Even Surface

- Reduces waste blow-out created by wheeled compactors
- Compaction achieved quicker because operator does not have to go over and over and over the mounds often creating more problems in the process
- Maximum compaction is achieved in less time
- 15-25% more waste compacted per sq. yard with the twin drum technology
- 30-40% less time to compact area results in savings of fuel, labor, and service



TANA ROLLER COMPACTION (TRC) METHOD

- Two full-width passes creating uniform compaction
- Maximum capacity tons per hour
- Excellent traction with no loss of compaction force
- Smooth, level surface
- High spots get maximum force applied while blade does not dig in
- No cabin swing or weight shift
- 160 to 220 cleats per compactor maximizing crushing force
- Even load spreading providing maximum compaction
- 28 to 40 scraper bars keep drums clean and 8 wire cutters eliminate wrapping

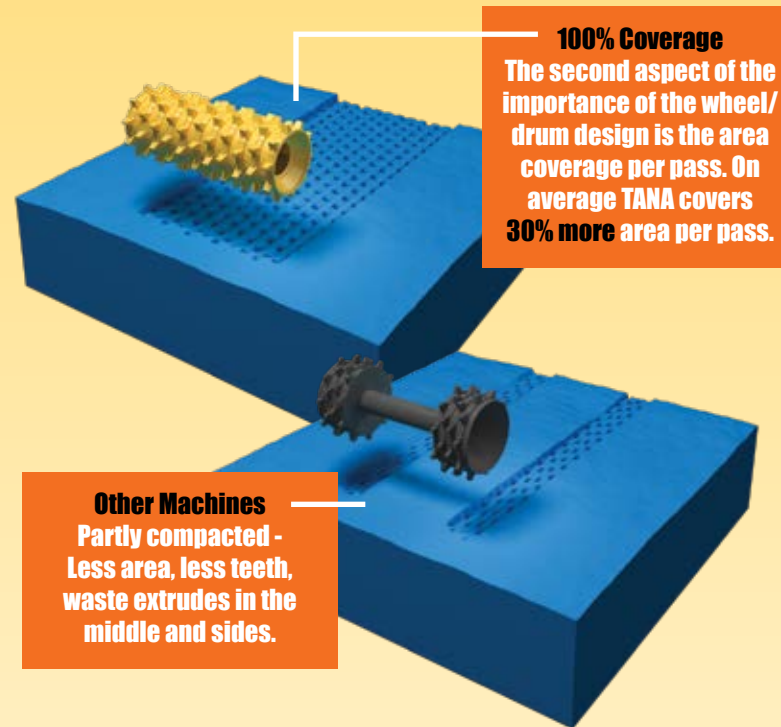

FINANCIAL IMPACT

Proven Increased Profits
Higher Compaction = \$MILLIONSS over the life of the unit

1,000 tons per day, \$50/Ton Tipping, \$1.2 Million Life Cost/Acre, with a **20% better compaction**

33% fewer passes

40-60% less cover soil
12% improved fuel economy

\$3.1 million additional revenue per year, OR \$1.1 million savings in landfill life cost per year

33% less fuel
33% less maintenance
33% less labor

STATE OF THE ART INFORMATION MANAGEMENT SYSTEM

Maximum uptime

- Remote access for quicker and more accurate trouble shooting by customer and TANA technical support
- Critical alarm notifications can be sent to multiple people by e-mail
- Reminders for scheduled maintenance can be sent to multiple people by e-mail

Operational Cost Analysis through TANA ProTrack® reports (additional option)

- Monthly operational reports provided through e-mails, e.g. working hours, fuel consumption, work load...

PROTRACK INTERFACE

- Reports
- Alarms
- Upcoming maintenances

Fleet management

- Operating hours
- Real-time view
- Fault finding
- Quick support for your unit



A SMART GPS SOLUTION FOR EFFICIENT LANDFILL MANAGEMENT



Optimized landfill space usage and efficient volume reduction

- A digitally imported filling plan gives the operator a real-time view of density compaction results through a color 3D interface
- Colored squares indicate density compaction goal has been achieved

Increased profits realized

- Reduction in the number of passes will reduce the total fuel consumption while achieve maximum density compaction
- Machine uptime is increased through reduced idle time and unplanned transfers
- All data is sent to TANA ProTrack® where reports can be generated and combined with other operational information
- Results in flatter surfaces and uniform density compaction on the entire landfill

Effortless use

- Crisp, color touch screen, Windows-based software
- Online downloading of work plans and software updates
- Remote connection results in quicker trouble-shooting and problem solving capabilities
- Updates and corrective action instructions are available real-time through the computer display as long as internet connection is available

RIGID FRAME MAXIMIZES CRUSHING FORCE

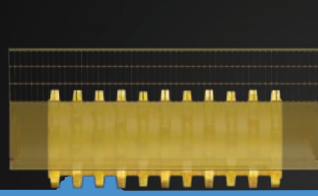

Crushing force is always **50%** of the total compactor weight and blade stays even and does not dig in

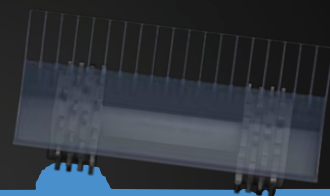

Crushing force is never more than **25%** of the total compactor weight and blade tip gouges the waste

RIGID FRAME ENABLES EVEN SPREADING

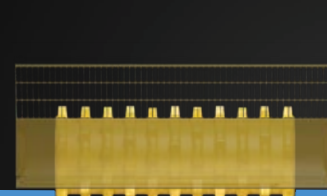

Waste is spread in level layers and voids are filled by COMPACTION resulting in a smoother, denser compacted area versus what any wheeled compactor can achieve. The blade remains level for an even spread of waste



Oscillation causes one wheel to drop into voids while waste on both sides of it are pushed out and up causing mounds of un-compacted waste to form. The blade also gouges out additional voids thus compounding the problem

TANA'S HYDROSTATIC SYSTEM VS. POWER SHIFT TRANSMISSION

The TANA Design:

- Two Pumps
- 2, 3 or 4 Final Drives & Motors

TANA's Design Eliminates:

- Torque converter
- Power shift transmission
- Transfer gearbox
- Drive shafts & universal joints
- 2 differentials
- Disc Brakes (Service)
- Complicated control systems
- Clutch Pedal & Clutch
- Brake Pedal & Controllers

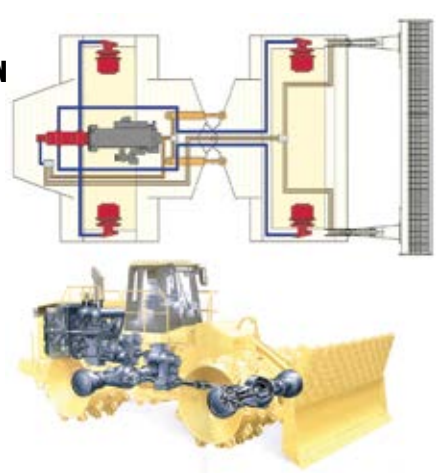

TANA'S EXCELLENT GROUND CLEARANCE – BEST IN THE MARKET

- Over 35 Inches of Ground Clearance
- No Belly Pan build-up of waste
- No build-up of waste in the belly pan creating fire hazards
- No power train shut downs due to debris in the power pack
- No vulnerable spaces or belly pans between axle ends



100% JOYSTICK CONTROL

- Easiest Operational Control System
- No Foot Controls

RESULTS: TANA'S simple hydrostatic system allows for a more efficient operator, less downtime and an overall cost advantage that is not possible with a power shift mechanical drive



TANA'S SERVICE ADVANTAGE

- Easy access to all service locations
- Unobstructed walk-around on deck level



TANA'S SUPERB STABILITY

- Maximum sideways tilt angle of over 50 degrees
- Climb and descent angles are only limited by available traction
- Minimum Cabin Sway due to rigid frame

TANA'S CAB-FORWARD DESIGN

- Cab is mounted to the front frame
- Weight is equally distributed to each drum
- Noise level only 72.5 dB – lowest in the market
- Improved visibility out of rear window
- Design allows more efficient blade operation
- Full visibility of the blade at any articulation
- Operator can always see bottom of blade for optimal spreading
- Improved all-around visibility
- Improved safety with better visibility

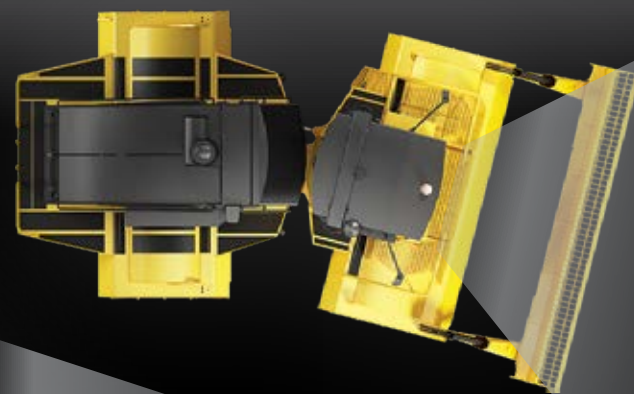

CABIN AND CONTROLS

- Pressurized, heat and sound insulated cabin with cabin lights
- Insulation materials in accordance with ISO 3795 - 72.5 dB(A)
- Air-suspended swiveling operator's seat with head rest, built-in controls, heated seat and seat belt
- Laminated safety glass windows with sun visor
- Socket for mobile phone charger, radio/CD/USB player
- Front and rear windshield wipers and washers
- Heater and A/C unit
- Emergency exit, lockable door, shelf and lockers, external rear-view mirrors, foot support, inside mirror
- Replaceable cabin air filters, pre-filter grade EU3, micro filter grade EU7, and optional grade EU14 and active carbon filters

Gauges included in TANA Control System (TCS)

- Engine oil pressure, engine intake manifold, engine oil and hydraulic oil temperature, engine coolant
- Final drive planetary temperature
- Fuel level, total fuel consumption
- Voltage, tachometer, boost pressure, engine working hours
- Engine load rate

System warnings included in TCS

(indicator light, audible warning and alarm log)

- Engine air filter contamination
- Hydraulic oil temperature, low hydraulic level, high hydraulic oil contamination, and hydraulic oil return line filter contamination
- Charge pressure filter contamination and low charge pressure
- Additional alarms total more than 500.

Controls

- Transmission on/off and parking brake
- Emergency shut down
- Ignition switch: power on/off and starting
- Heater and air conditioning unit, cabin temperature control
- Windshield wipers and washers, lights

Joystick controls integrated in arm-rests

- Control levers will return to neutral position automatically when released and all related movements will stop
- Programmable joysticks control driving speed, direction, steering, dozer blade, and horn

COMPACTION DRUMS

Uniform full width drums with forged solid steel crushing teeth. Adjustable scraper bars on both sides of the drums and adjustable steel wire cutters in the ends of drums.

HYDRAULIC CYLINDERS

Interchangeable cylinders equipped with spherical bearings, hardened pins and auto lubrication

FRAME

The drum frame acts as a shell around the drum, which helps to prevent waste rising into the upper parts of the machine. Angle of articulation: left 40 degrees; right 40 degrees

SERVICE PLATFORMS AND PROTECTION

Service platforms and steps are equipped with handrails and non-slip safety surfaces. Engine housing is protected with lockable hoods that swing open out of the way, exposing all engine components for easy access.

VANDALISM PROTECTION

- Lockable cabin, engine compartment and fuel tank filling cap
- Electronic key for ignition

ENGINE

- See specifications on page 7
- 1 piece fuel filter and water separator / 1 piece oil filter
- Landfill designed radiator
- Starter motor 24V / Alternator 24V, 70A



ROPS / FOPS

- ROPS and FOPS in accordance with ISO 3471:2008 and 3449:2005

BRAKES

- Service brakes: hydrostatic transmission acts as service brakes, a separate circuit for each drum
- Parking/emergency brakes: hydraulically released, spring-actuated, multi-disk brake integrated into planetary system

AUXILIARY HYDRAULICS

Controls for steering and blade operation

HYDRAULIC OIL TANK

The hydraulic oil tank is protected inside the engine hood

- Electric filling pump with filter
- Breather filter

FUEL TANK & UREA TANK

The 201 gallon (760 liter) fuel tank is protected under the cabin and is equipped with a suction strainer, drain cock, and level sensor. The 14 gallon (56 liter) urea tank is protected inside the rear frame and is equipped with a suction strainer and level sensor.

ELECTRICAL EQUIPMENT

- 24 VDC system
- Batteries 12V 170Ah, 2 pcs
- Lights: front 4 pcs, rear 4 pcs
- Horn
- Socket for hand light in engine compartment
- Back-up alarm, main circuit breaker, voltage reducer for radio

POWER TRANSMISSION

- Closed circuit, hydrostatic transmission
- Separate systems for both drums
- Two speed ranges with infinite variable speed control

Pumps

- One tandem axial pump arrangement
- Variable displacement with electrical proportional control

Motors

- Two, three, or four variable displacement plug-in motors

Cooling of hydraulic system

- Air-operated oil cooler
- Removable air filtration screen

Final drive planetary system

- Transmits hydraulic output to the drums
- Three-stage planetary gearboxes (2 pcs)
- Splash lubrication system

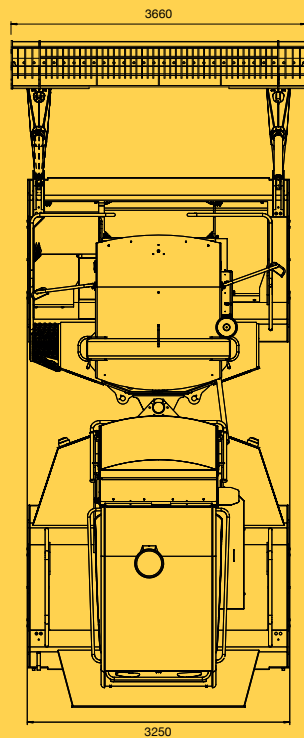

E260 & E320

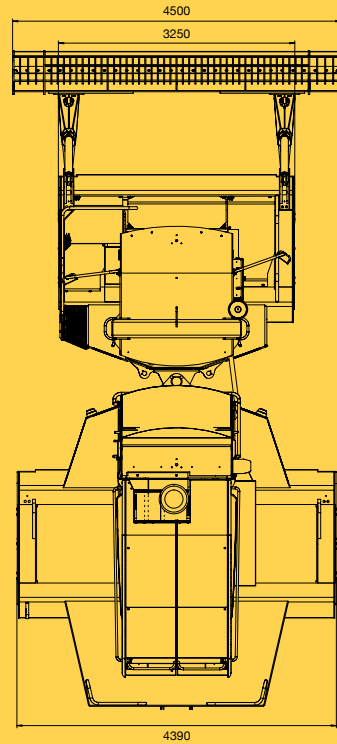
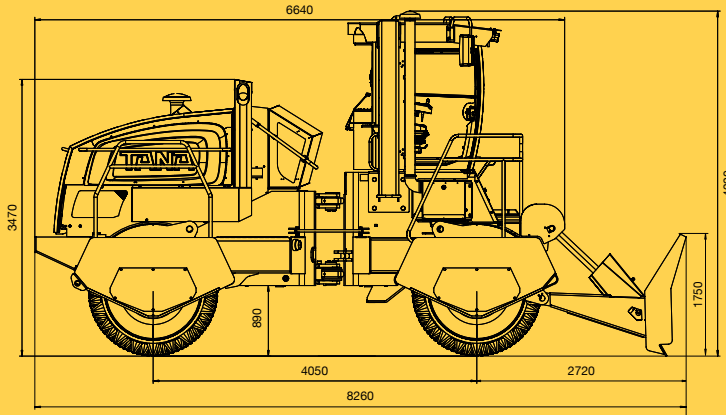

E380

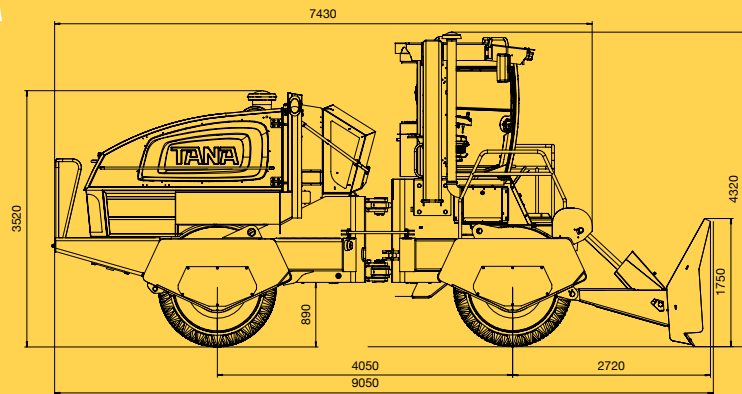

E450 & E520

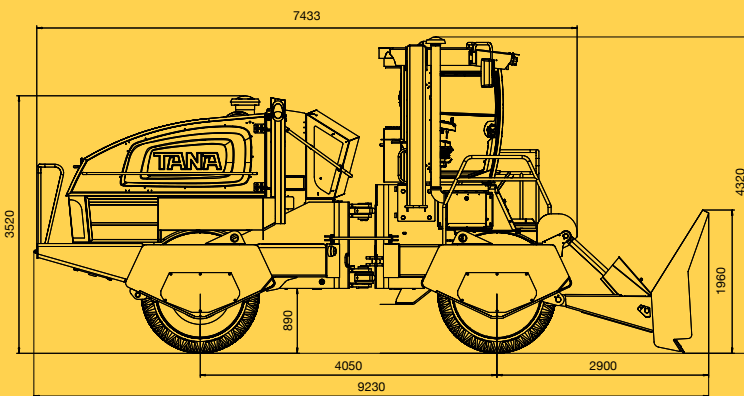
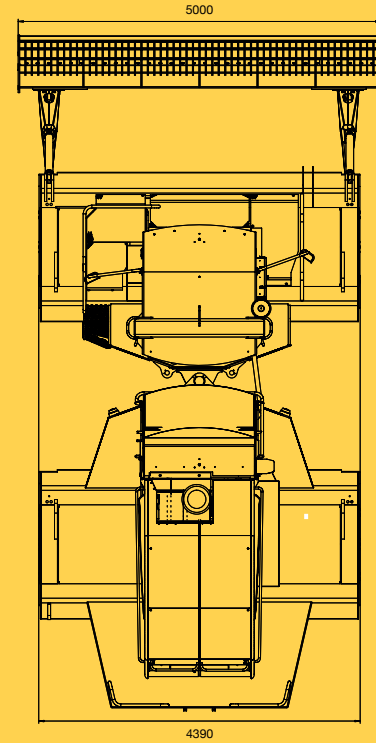

Measurements in Millimeters

**OVER 1,500 LANDFILLS
AROUND THE WORLD
ARE USING TANA
COMPACTORS**

GENERAL SPECIFICATIONS	E260 ECO	E320 ECO	E380 ECO	E450 ECO	E520 ECO
Operating Weight	57,321 lbs (26,000 kg)	70,548 lbs (32,000kg)	83,775 lbs (38,000kg)	99,208 lbs (45,000kg)	115,000-121,000 lbs (52,000-55,000kg)
Total Length	325 inches (8,260 mm)	325 inches (8,260 mm)	356 inches (9,050 mm)	363 inches (9,230 mm)	363 inches (9,230 mm)
Total Width	144 inches (3,600 mm)	144 inches (3,600 mm)	177 inches (4,500 mm)	197 inches (5,000 mm)	197 inches (5,000 mm)
Total Height	170 inches (4,320 mm)	170 inches (4,320 mm)	170 inches (4,230 mm)	170 inches (4,320 mm)	170 inches (4,320 mm)
Wheel Base	160 inches (4,050 mm)	160 inches (4,050 mm)	160 inches (4,050 mm)	160 inches (4,050 mm)	160 inches (4,050 mm)
Ground Clearance	35 inches (890mm)	35 inches (890mm)	35 inches (890mm)	35 inches (890mm)	35 inches (890mm)
Length Without Dozer Blade	261 inches (6,440 mm)	261 inches (6,440 mm)	293 inches (7,430 mm)	293 inches (7,430 mm)	293 inches (7,430 mm)
Width Without Dozer Blade	128 inches (3,250 mm)	128 inches (3,250 mm)	173 inches (4,390 mm)	173 inches (4,390 mm)	173 inches (4,390 mm)
Inside Turning Radius	153 inches (3,880 mm)	153 in (3,880 mm)	130 inches (3,310 mm)	130 inches (3,310 mm)	130 inches (3,310 mm)
Driving Speed Ranges	0-4.5 mph (0-7 km/h)	0-4.5 mph (0-7 km/h)	0-4.5 mph (0-7 km/h)	0-4.5 mph (0-7 km/h)	0-4.5 mph (0-7 km/h)
Crushing Force	28,551 lbs (127 kN)	35,295 lbs (157 kN)	41,815 lbs (186 kN)	49,683 lbs (221kN)	57,327 lbs (255 kN)
COMPACTION DRUMS	FRONT / REAR DRUM	FRONT / REAR DRUM	FRONT / REAR DRUM	FRONT / REAR DRUM	FRONT / REAR DRUM
Crushing/Compaction Width	105 inches (2,660 mm) / 105 inches (2,660 mm)	105 inches (2,660 mm) / 105 inches (2,660 mm)	105 inches (2,660 mm) / 150 inches (3,800 mm)	150 inches (3,800 mm) / 150 inches (3,800 mm)	150 inches (3,800 mm) / 150 inches (3,800 mm)
Diameter	64 inches (1,620 mm)	64 inches (1,620 mm)	64 inches (1,620 mm)	64 inches (1,620 mm)	64 inches (1,620 mm)
No. of Feet Front/Rear	80/80 pcs	80/80 pcs	80/110 pcs	110/110 pcs	110/110 pcs
Height of Feet	8 inches (200 mm)	8 inches (200 mm)	8 inches (200 mm)	8 inches (200 mm)	8 inches (200 mm)
No. of Scapers Bars (Front/Rear)	14/14 pcs	14/14 pcs	14/20 pcs	20/20 pcs	20/20 pcs
No. of Wirecutters (Front/Rear)	4/4 pcs	4/4 pcs	4/4 pcs	4/4 pcs	4/4 pcs
DOZER BLADE	TANA straight blade, trash screen, reversible cutting edges	TANA straight blade, trash screen, reversible cutting edges	TANA straight blade, trash screen, reversible cutting edges	TANA straight blade, trash screen, reversible cutting edges	TANA straight blade, trash screen, reversible cutting edges
Width	144 inches (3,660 mm)	144 inches (3,660 mm)	177 inches (4,500 mm)	197 inches (5,000 mm)	197 inches (5,000 mm)
Height	69 inches (1,750 mm)	69 inches (1,750 mm)	69 inches (1,750 mm)	77 inches (1,960 mm)	77 inches (1,960 mm)
Movement Above Ground Level	46 inches (1,170 mm)	46 inches (1,170 mm)	46 inches (1,170 mm)	48 inches (1,230 mm)	48 inches (1,230 mm)
Movement Below Ground Level	6 inches (150 mm)	6 inches (150 mm)	6 inches (150 mm)	6 inches (150 mm)	6 inches (150 mm)
POWER PACK					
Engine	Cummins QSL9-C265, 265 HP (198kW)/2,000 rpm	Cummins QSL9-C320, 345 HP (257 kW)/2,000 rpm	Cummins QSX15-C450, 450 HP (336 kW)/2,100 rpm	Cummins QSX15-C535, 580 HP (433 kW)/1,800 rpm	Cummins QSX15-C535, 580 HP (433 kW)/1,800 rpm
Power Rating (SAE J1995)	265 HP (198kW)@2,000 rpm	320 HP (239kW)@2,200 rpm	450 bhp (336kW)@2,100 rpm	535 bhp (399kW)@2,100 rpm	535 bhp (399 kW)@2,100rpm
Displacement	8.9 L	8.9 L	15 L	15 L	15 L
Engine Data	Six cylinder, turbocharger and aftercooler, liquid cooled, EU STAGE IV, US EPA Tier 4F, CARB TIER 4	Six cylinder, turbocharger and aftercooler, liquid cooled, EU STAGE IV, US EPA Tier 4F, CARB TIER 4	Six cylinder, turbocharger and aftercooler, liquid cooled, EU STAGE IV, US EPA Tier 4F, CARB TIER 4	Six cylinder, turbocharger and aftercooler, liquid cooled, EU STAGE IV, US EPA Tier 4F, CARB TIER 4	Six cylinder, turbocharger and aftercooler, liquid cooled, EU STAGE IV, US EPA Tier 4F, CARB TIER 4
Hydrostatic Transmisison	Sauer-Danfoss	Bosch Rexroth	Bosch Rexroth	Bosch Rexroth	Bosch Rexroth
Power Transmission Pumps	1 tandem pump: variable displacement axial piston pumps with electrical proportional control	1 tandem pump: variable displacement axial piston pumps with electrical proportional control	1 tandem pump: variable displacement axial piston pumps with electrical proportional control	1 tandem pump: variable displacement axial piston pumps with electrical proportional control	1 tandem pump: variable displacement axial piston pumps with electrical proportional control
Power Transmission Motors	2 variable displacement plug-in motors	2 variable displacement plug-in motors	3 variable displacement plug-in motors	4 variable displacement plug-in motors	4 variable displacement plug-in motors
Fuel Tank	201 gallons (760 liters)	201 gallons (760 liters)	201 gallons (760 liters)	201 gallons (760 liters)	201 gallons (760 liters)
Urea Tank	14 gallons (56 liters)	14 gallons (56 liters)	14 gallons (56 liters)	14 gallons (56 liters)	14 gallons (56 liters)
Replaceable Cabin Air Filtration Grade	Pre-filter grade EU3, Micro filter grade EU7, Grade EU14 (option), Active carbon filter (option)	Pre-filter grade EU3, Micro filter grade EU7, Grade EU14 (option), Active carbon filter (option)	Pre-filter grade EU3, Micro filter grade EU7, Grade EU14 (option), Active carbon filter (option)	Pre-filter grade EU3, Micro filter grade EU7, Grade EU14 (option), Active carbon filter (option)	Pre-filter grade EU3, Micro filter grade EU7, Grade EU14 (option), Active carbon filter (option)
Service Brakes	Hydrostatic transmisson acts as service brakes with dual circuit parking brakes	Hydrostatic transmisson acts as service brakes with dual circuit parking brakes	Hydrostatic transmisson acts as service brakes with dual circuit parking brakes	Hydrostatic transmisson acts as service brakes with dual circuit parking brakes	Hydrostatic transmisson acts as service brakes with dual circuit parking brakes

FIRST LANDFILL IN NORTH AMERICA WITH A TANA E-SERIES LANDFILL COMPACTOR

Glenmore Landfill's Life Expectancy Increased by 12-15 Years

For increasing the compaction efficiency, the landfill purchased a Tana E520 landfill compactor. According to the Solid Waste Supervisor, Ken Muller, they have increased their density over 20 percent after the first few months of operation. At the end of two years of operation the landfill has improved densities from .7 tons per cubic meter to 1.1 tons per cubic meter (57% improvement) over the previously 4-wheel compactor of the same weight class.

"Because of the full width twin drums and the width of the whole machine, just one pass compacts everything under it. We used to drive over an area three times before we hit our maximum space between the wheels that you'd have to slide over half a width of the unit to get that material done. The Tana unit is giving us much better compaction and we burn less fuel because we don't have to run the unit as much. We no longer have to drive it eight hours per day. We drive it three hours per day and get a better compaction. Compaction has been improved 57%, machine operational time and fuel usage has been decreased from three hours to eight hours or a 62.5% reduction." Says Muller.

Since changing from a four-wheel compactor to the twin drum design of Tana E520, the use of cover soil has been decreased greatly. Rather than using six inches of cover soil daily, the new operation with the Tana compactor only requires a quarter-inch of fiber mulch. "It saves us a considerable amount of airspace over the year," says Muller.

The City of Kelowna sees the new Tana E520 Compactor as an investment. "It's playing a big part on the operations and has shown remarkable improvements over the ineffectiveness caused by previous compactors. It's a completely different configuration and concept in landfill compaction and it seems to be working well. The unit is giving us much better compaction as we burn less fuel because we don't have to run the unit as much," stated Muller.

Currently generating revenues of \$12 million a year, the City is expecting up to \$180 million more from the landfill with the new, improved operations using the Tana E520 while reducing their operating cost by over 62.5 percent.

Capital News, June 13th, 2013 | Environmental XPRT,
December 19, 2014



DESIGNED TO IMPROVE YOUR BOTTOM LINE



Humdinger Equipment, Ltd.

3202 Clovis Road
Lubbock, Texas 79415
Telephone: 806-771-9944
Fax: 806-771-9945
Email: sales@humdingerequipment.com

www.humdingerequipment.com | www.tanarecycling.com



1971



1984



1990



1997



2001



2007



2011



2014