

HDC50/60 HEAVY-DUTY DRIVE-ON LIFT

LIFT ACCESSORIES

25,000 LBS. CAPACITY ROLLING BRIDGE JACK

The optional 25K rolling bridge can be attached to the runway to create various lifting options to make it even more versatile.



Shown: RJ25001L 25,000 lbs. capacity rolling jack

LED LIGHTING

High-efficiency LED lighting, single touch operation system provides hands-free lighting under the vehicle from the lift's control panel.



Shown: M140002

MOBILITY KIT

Optional wheel kit is available to provide portability for each column adding movement within your shop.



Shown: M140111

RAMP KIT

Adding a drive-thru ramp kit to lift runways creates a quick and easy on-off service operation for service bays.

Model # APRAMP10DTKIT (10' / 3048mm drive-thru ramp kit)

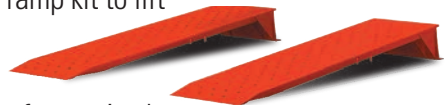

SHIM KIT

Not every shop floor is perfect. Using optional shims during installation ensures a lift is level and operates at optimum performance. (Call factory for details)

SPECIFICATIONS*

Model:	HDC50 HDC60
Lifting Capacity	50,000 lbs. (22679kg) 60,000 lbs. (27215kg)
Maximum Wheelbase	28' (336" / 8534mm) 33' (396" / 10058mm)
Max. Rise - floor to runway top	78" (1981mm)
A. Length Overall	35' 7-1/2" (10858mm) 40' 7-1/2" (12382mm)
B. Width Overall - outside controls	15' 9" (4800mm)
Height of Columns	144 - 3/4" (3677mm)
C. Width of Runways	28" (711mm)
D. Drive Thru Between Columns	11'-10" (3607mm)
E. Runway Spacing	45" (1143mm)
Rise Time	65 seconds
Ramp Angle	10 degrees
Power Usage	Battery powered, charges on 110V

*BOTH 28' AND 33' RUNWAY LENGTH MODELS ARE AVAILABLE AS 50,000 AND 60,000 LBS. CAPACITY LIFTS

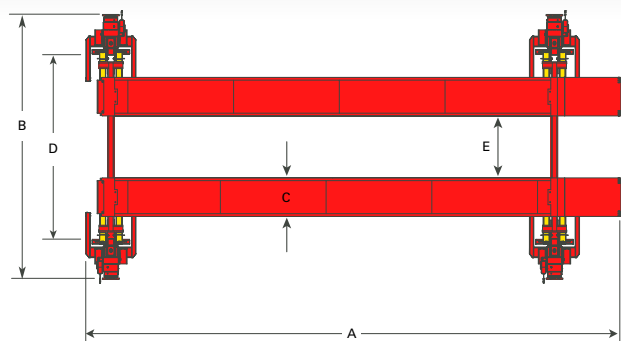

Rotary World Headquarters
2700 Lanier Drive
Madison, IN 47250, USA
www.rotarylif.com



Contact Information

Sales: p 800.640.5438
f 800.578.5438
e userlink@rotarylif.com
Tech. Support: p 800.445.5438
f 800.822.6502
e userlink@rotarylif.com



THE ROTARY LIFT PROMISE

Only Rotary offers the right combination of experience, quality product selection and service you've come to expect from the world leader.



Lit# Rotary HDC50_60_FourPost brochure_2014.05
©2014 VEHICLE SERVICE GROUP™, Printed in U.S.A., All Rights Reserved. Unless otherwise indicated, ROTARY LIFT, VEHICLE SERVICE GROUP™, DOVER and all other trademarks are property of Dover Corporation and its affiliates.
HDC Control Panel System (US Patent No. 8083033 B2)



HDC50/60

HEAVY-DUTY FOUR POST DRIVE-ON LIFT



ROTARY LIFT

THE WORLD'S MOST TRUSTED LIFT



Model Shown: HDC60U000 60,000 lbs. capacity four-post drive on lift

www.rotarylif.com

HDC50/60

HEAVY-DUTY DRIVE-ON LIFT

Operator friendly designs and industry exclusive features offer you a drive-on four post lift that's easier to use and faster than similar competitive lifts.

THIRD PARTY CERTIFIED

Our drive-on lifts meet the ANSI/ALI ALCTV 2011 standard, including the required third-party validation.

Your assurance of certification is the gold ALI/ETL certified label.



Shown: HDC60U000 (60,000 lbs. capacity)

TIME IS MONEY

Make sure your shop is ready for more business servicing larger vehicles with ease. Technicians can work quicker and more efficiently with a level peace of mind. And, raise your fleet faster with an industry best rise time of 65 seconds!

LOWER YOUR COST OF OWNERSHIP

With no complicated or expensive electrical installation, no cables, chains or sheaves to maintain and fewer moving parts, the fully hydraulic HDC50/60 is one of the most dynamic four-post lifts in the industry! DC battery operated with an onboard charger that needs only 110v electricity to charge, this affordable four post lift is easy to operate and inexpensive to own. Choose the lift model that fits your needs best - both model lengths are available in both lifting capacities!

ENVIRONMENTALLY FRIENDLY

- Surface mounted and anchored, it requires no excavation or site preparation
- Optional high efficiency LED lighting saves electricity and money over comparable incandescent and fluorescent lighting
- Bio fluid ready

OPTIONAL ACCESSORIES

Productivity is the key for any shop, so our lifts are packed with optional accessories that help your technicians get vehicles up on the lift and back on the road faster and easier than anyone else.

See back page.



HDC Four-Post

PRODUCTIVITY & PERFORMANCE

1. **PATENTED CONTROL PANEL**
2. **DC POWER - PROVIDES SPEED**
3. **INVERTED HYDRAULIC CYLINDER**
4. **THIRD-PARTY ETL GOLD CERTIFIED**

DESIGN FEATURES

- 28" wide runways with two available lengths and capacities handle any number of vehicles from cars to the largest trucks
- Clear floor four-post design creates an open work area free of interference
- 78" lifting height benefits the tallest techs
- Standard internal airline connections let two rolling jacks operate simultaneously and provides outlets for air tools

BATTERY OPERATED LIFT WITH ON-BOARD CHARGER

- Generates faster lift cycle times
- at least 1.5 X faster than comparable lifts
- No special AC wiring costs or requirements
- Low electrical usage
- DC battery power* and 110V charging
- Fully functional when the power goes out

* Battery purchased separately for international use

HORSESHOE WIRING

The HDC is connected by three communication cables, (forming a horseshoe) protected within the lift runways.

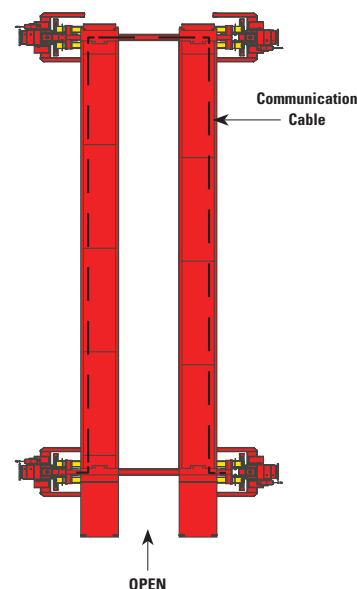

LOW DRIVE-ON HEIGHT

Ramps and runways accommodate a variety of vehicle types. Optional drive thru ramp kit available.



Accommodates wheelbases up to 33'



Shown: HDC60U000 (60,000 lbs. capacity)

INVERTED HYDRAULIC CYLINDER

The hydraulic cylinder is inverted inside the carriage so the chrome piston rod is protected from debris and damage - extending the life of the column and reducing maintenance frequency and cost

WHEEL CHOCKS

Automatic wheel chocks engage when the lift is raised and ramps are off the floor

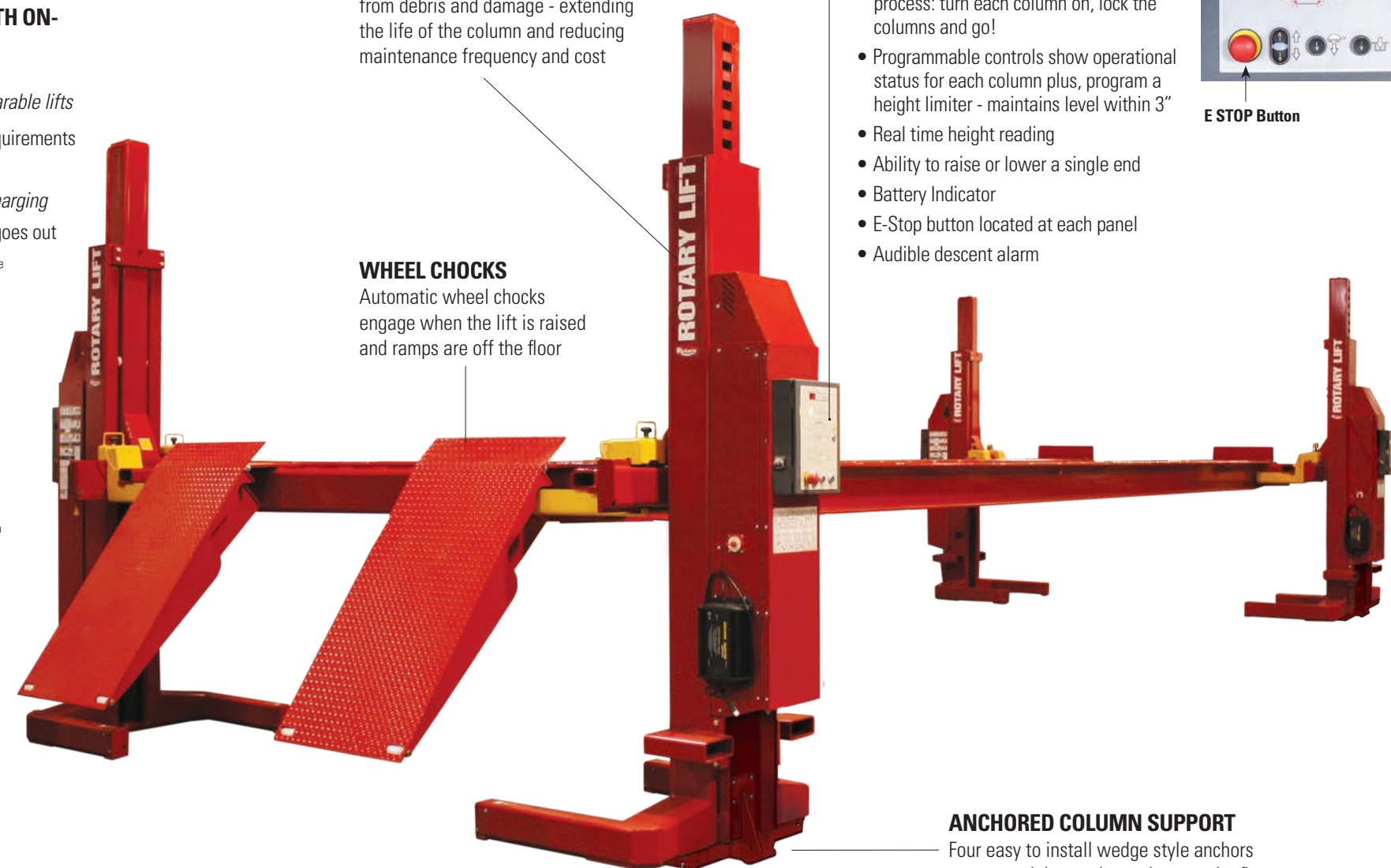

PATENTED CONTROL SYSTEM

Operate lift from ANY post with this user-friendly, exclusive control system

- Intuitive controls - lift can be controlled from ANY column
- Position memory - lifting cycles are configured and set creating a two step process: turn each column on, lock the columns and go!
- Programmable controls show operational status for each column plus, program a height limiter - maintains level within 3"
- Real time height reading
- Ability to raise or lower a single end
- Battery Indicator
- E-Stop button located at each panel
- Audible descent alarm



E STOP Button

ANCHORED COLUMN SUPPORT

Four easy to install wedge style anchors secure each heavy duty column to the floor



Shown: HDC60U000 (60,000 lbs. capacity)