

Prepared for:
 NC SHERIFFS ASSOCIATION
 PO BOX 20049
 RALEIGH, NC
 27619
 CONTRACT 23-03-0524

Prepared by:
 Terry Keith
 Excel Truck Group
 4633 Equipment Drive
 Charlotte, NC 28269

S P E C I F I C A T I O N P R O P O S A L : C A A S M 2 - 1 0 6 T Y P E 1 - A D A M B U L A N C E C H A S S I S

| Data Code | Description | Weight Front | Weight Rear |
|------------------------------|---|-----------------|----------------|
| Price Level | | | |
| PRL-26M | CURRENT 2023 MY | | |
| Data Version | | | |
| DRL-032 | SPECPRO21 DATA RELEASE VER 032 | | |
| Vehicle Configuration | | | |
| 001-172 | M2 106 CONVENTIONAL CHASSIS | 5,709 | 3,503 |
| 004-223 | 2023 MODEL YEAR SPECIFIED | | |
| 002-004 | SET BACK AXLE MANEUVERABILITY | | |
| 003-001 | LH PRIMARY STEERING LOCATION | | |
| General Service | | | |
| AA6-002 | DOMICILED USA (<i>EXCLUDING</i> CALIFORNIA AND CARB OPT-IN STATES); CARB OPTIONAL | | |
| A85-006 | RESCUE AND EMERGENCY SERVICE | | |
| AA4-011 | FIXED LOAD COMMODITY | | |
| AA5-002 | TERRAIN/DUTY: 100% (ALL) OF THE TIME, IN TRANSIT, IS SPENT ON PAVED ROADS | | |
| AB1-008 | MAXIMUM 8% EXPECTED GRADE | | |
| AB5-001 | SMOOTH CONCRETE OR ASPHALT PAVEMENT MOST SEVERE IN-TRANSIT (BETWEEN SITES) ROAD SURFACE | | |
| 995-091 | MEDIUM DUTY <i>PLUS EXCEL EMS</i> TRUCK WARRANTY | | |
| A66-99D | EXPECTED FRONT AXLE LOAD: 8000 lbs. | | |
| A68-99D | EXPECTED REAR DRIVE AXLE LOAD: 15000 lbs. | | |
| A63-99D | GROSS VEHICLE WEIGHT CAPACITY: 23000 lbs. | | |
| Truck Service | | | |
| AA3-024 | AMBULANCE BODY | | |
| A88-99D | EXPECTED TRUCK BODY LENGTH: 168 in. (+/-) | | |
| RTK-1AA | APPROVAL TO SHARE SPEC WITH TEM | | |



Prepared for:
 NC SHERIFFS ASSOCIATION
 PO BOX 20049
 RALEIGH, NC
 27619
 CONTRACT 23-03-0524

Prepared by:
 Terry Keith
 Excel Truck Group
 4633 Equipment Drive
 Charlotte, NC 28269

| Data Code | Description | Weight Front | Weight Rear |
|---|---|--------------|-------------|
| Engine | | | |
| 101-22C | CUMMINS B6.7 300EV, 300 HP @ 2600 RPM, 2600 GOV, 660 LB-FT @ 1600 RPM, FIRE/RESCUE | | |
| Programmable Electronic Parameters | | | |
| 79A-075 | 75 MPH ROAD SPEED LIMIT | | |
| 79B-003 | CRUISE CONTROL SPEED LIMIT 3 MPH HIGHER THAN ROAD SPEED LIMIT | | |
| 79F-004 | CUMMINS TRIP INFORMATION REPORTS ENABLED: LEVEL 1 - 4 MPH, LEVEL 2 - 7 MPH ABOVE ROAD SPEED LIMIT | | |
| 80C-004 | ENGINE BRAKE WITH CRUISE CONTROL ENABLED AT 2 MPH ABOVE SET SPEED, THEN 1 MPH INCREMENT BETWEEN BRAKING LEVELS | | |
| 80E-001 | ENGINE FAN ENABLED WITH RETARDER | | |
| 80F-001 | AUTOMATIC MAINTENANCE MONITOR WITH ALERT AT 5% OF INTERVAL REMAINING | | |
| EA8-010 | ENGINE PROTECTION: LOW COOLANT LEVEL | | |
| Engine Equipment | | | |
| 99C-021 | 2010 EPA/CARB/GHG21 CONFIGURATION | | |
| 99D-010 | NO 2008 CARB EMISSION CERTIFICATION | | |
| 105-001 | ENGINE MOUNTED OIL CHECK AND FILL | | |
| 014-102 | SIDE OF HOOD AIR INTAKE WITH FIREWALL MOUNTED DONALDSON AIR CLEANER | | |
| 124-1E7 | DR 12V 275 AMP 40-SI BRUSHLESS PAD ALTERNATOR WITH REMOTE BATTERY VOLTAGE SENSE | 10 | |
| 292-1E1 | (2) ODYSSEY EXTREME ABSORBED GLASS MAT BATTERIES; PC2150S-H; GROUP 31 12 VOLT 2300 CCA; THREADED STUDS; WARRANTIED BY ODYSSEY | | |
| 282-001 | SINGLE BATTERY LH SIDE UNDER CAB | | |
| 291-017 | WIRE GROUND RETURN FOR BATTERY CABLES WITH ADDITIONAL FRAME GROUND RETURN | | |
| 293-060 | POSITIVE LOAD DISCONNECT WITH CAB MOUNTED CONTROL SWITCH WITH LOCKING PROVISION; MOUNTED ON FLOOR OUTBOARD OF DRIVER SEAT | 10 | |
| 295-029 | POSITIVE AND NEGATIVE JUMPSTART POSTS LOCATED ON RH FRAME UNDER HOOD | 2 | |
| 107-032 | CUMMINS TURBOCHARGED 18.7 CFM AIR COMPRESSOR WITH INTERNAL SAFETY VALVE | | |
| 108-002 | STANDARD MECHANICAL AIR COMPRESSOR GOVERNOR | | |

Prepared for:
 NC SHERIFFS ASSOCIATION
 PO BOX 20049
 RALEIGH, NC
 27619
 CONTRACT 23-03-0524

Prepared by:
 Terry Keith
 Excel Truck Group
 4633 Equipment Drive
 Charlotte, NC 28269

| Data Code | Description | Weight Front | Weight Rear |
|-----------|--|--------------|-------------|
| 131-013 | AIR COMPRESSOR DISCHARGE LINE | | |
| 152-039 | GVG, FIRE, AND EMERGENCY SERVICE VEHICLES ENGINE WARNING | | |
| 128-1AR | CUMMINS ENGINE INTEGRAL BRAKE WITH VARIABLE GEOMETRY TURBO; ON/OFF WITH BRAKE LAMPS | 20 | |
| 016-106 | RH INBOARD FRAME MOUNTED HORIZONTAL AFTERTREATMENT SYSTEM ASSEMBLY WITH LH HORIZONTAL TAILPIPE EXITING FORWARD OF REAR TIRES | -30 | -30 |
| 28F-007 | ENGINE AFTERTREATMENT DEVICE, AUTOMATIC OVER THE ROAD ACTIVE REGENERATION AND DASH MOUNTED SINGLE REQUEST/INHIBIT SWITCH | | |
| 23U-001 | 6 GALLON DIESEL EXHAUST FLUID TANK | | |
| 43X-002 | LH UNDER CAB MEDIUM DUTY STANDARD DIESEL EXHAUST FLUID TANK LOCATION | | |
| 273-058 | AIR POWERED ON/OFF ENGINE FAN CLUTCH | | |
| 276-001 | AUTOMATIC FAN CONTROL | | |
| 110-003 | CUMMINS SPIN ON FUEL FILTER | | |
| 118-001 | FULL FLOW OIL FILTER | | |
| 266-100 | 700 SQUARE INCH ALUMINUM RADIATOR | | |
| 103-039 | ANTIFREEZE TO -34F; OAT (NITRITE AND SILICATE FREE) EXTENDED LIFE COOLANT | | |
| 171-007 | GATES BLUE STRIPE COOLANT HOSES | | |
| 172-007 | GATES POWERGRIP SHRINK BAND HOSE CLAMPS WHERE POSSIBLE | | |
| 270-016 | RADIATOR DRAIN VALVE | | |
| 168-002 | LOWER RADIATOR GUARD | | |
| 134-001 | ALUMINUM FLYWHEEL HOUSING | | |
| 132-004 | ELECTRIC GRID AIR INTAKE WARMER | | |
| 155-058 | DELCO 12V 38MT HD STARTER WITH INTEGRATED MAGNETIC SWITCH | | |

Transmission

| | |
|---------|---|
| 342-1MT | ALLISON 2500 EVS AUTOMATIC TRANSMISSION WITH STANDARD PTO OPENING |
|---------|---|

Transmission Equipment

| | |
|---------|--|
| 343-301 | ALLISON VOCATIONAL PACKAGE 354 |
| 84B-003 | ALLISON VOCATIONAL RATING FOR FIRE TRUCK/EMERGENCY VEHICLE APPLICATIONS; AVAILABLE WITH ALL PRODUCT FAMILIES |

Prepared for:
 NC SHERIFFS ASSOCIATION
 PO BOX 20049
 RALEIGH, NC
 27619
 CONTRACT 23-03-0524

Prepared by:
 Terry Keith
 Excel Truck Group
 4633 Equipment Drive
 Charlotte, NC 28269

| Data Code | Description | Weight Front | Weight Rear |
|-----------|---|--------------|-------------|
| 84C-007 | PRIMARY MODE GEARS: 6 FORWARD GEARS WITH MANUAL SELECTION FOR 3, 2 AND 1, AVAILABLE FOR 2500 EVS | | |
| 84E-000 | PRIMARY SHIFT SCHEDULE RECOMMENDED BY DTNA AND ALLISON; THIS DEFINED BY ENGINE AND VOCATIONAL USAGE | | |
| 84G-000 | PRIMARY SHIFT SPEED RECOMMENDED BY DTNA AND ALLISON; THIS DEFINED BY ENGINE AND VOCATIONAL USAGE | | |
| 84J-000 | ENGINE BRAKE RANGE PRESELECT RECOMMENDED BY DTNA AND ALLISON; THIS DEFINED BY ENGINE AND VOCATIONAL USAGE | | |
| 84K-000 | ENGINE BRAKE RANGE ALTERNATE PRESELECT RECOMMENDED BY DTNA AND ALLISON; THIS DEFINED BY ENGINE AND VOCATIONAL USAGE | | |
| 353-066 | VEHICLE INTERFACE WIRING CONNECTOR WITH BLUNT CUTS AT END OF FRAME | | |
| 34C-001 | ELECTRONIC TRANSMISSION CUSTOMER ACCESS CONNECTOR FIREWALL MOUNTED | | |
| 341-018 | MAGNETIC PLUGS: ENGINE DRAIN, TRANSMISSION DRAIN, AXLE FILL AND DRAIN | | |
| 345-073 | DASH MOUNTED T-HANDLE CABLE SHIFT CONTROL WITH PARK BRAKE POSITION | | |
| 370-015 | WATER TO OIL TRANSMISSION COOLER, IN RADIATOR END TANK | | |
| 346-001 | TRANSMISSION OIL CHECK AND FILL | | |
| 35T-001 | SYNTHETIC TRANSMISSION FLUID (TES-295 COMPLIANT) | | |

Front Axle and Equipment

| | | | |
|---------|---|--|--|
| 400-1EW | DETROIT DA-F-8.0-3 8,000# FRONT AXLE | | |
| 402-021 | MERITOR 15X5 Q+ CAST SPIDER CAM FRONT BRAKES; DOUBLE ANCHOR, FABRICATED SHOES | | |
| 403-026 | FIRE AND EMERGENCY SEVERE SERVICE NON-ASBESTOS FRONT BRAKE LINING | | |
| 419-023 | CONMET CAST IRON FRONT BRAKE DRUMS | | |
| 409-006 | FRONT OIL SEALS | | |
| 408-001 | VENTED OIL FRONT HUB CAPS WITH WINDOW, CENTER, AND SIDE PLUGS | | |
| 416-022 | STANDARD SPINDLE NUTS FOR ALL AXLES | | |
| 405-031 | HALDEX AUTOMATIC FRONT SLACK ADJUSTERS WITH STAINLESS STEEL CLEVIS PINS | | |
| 536-050 | TRW THP-60 POWER STEERING | | |

Prepared for:
 NC SHERIFFS ASSOCIATION
 PO BOX 20049
 RALEIGH, NC
 27619
 CONTRACT 23-03-0524

Prepared by:
 Terry Keith
 Excel Truck Group
 4633 Equipment Drive
 Charlotte, NC 28269

| Data Code | Description | Weight Front | Weight Rear |
|--------------------------------|---|--------------|-------------|
| 539-003 | POWER STEERING PUMP | | |
| 534-015 | 2 QUART SEE THROUGH POWER STEERING RESERVOIR | | |
| 40T-004 | ROADRANGER SYNTHETIC FE 75W-90 LUBE | | |
| Front Suspension | | | |
| 620-032 | 8,000# TAPERLEAF FRONT SUSPENSION | -30 | |
| 619-005 | MAINTENANCE FREE RUBBER BUSHINGS - FRONT SUSPENSION | | |
| 629-004 | FRONT SWAYBAR | 60 | |
| 410-004 | FRONT SHOCK ABSORBERS | | |
| Rear Axle and Equipment | | | |
| 420-1M3 | MERITOR MS-17-14X 17,500# R-SERIES QUIET RIDE REAR AXLE | | -30 |
| 421-463 | 4.63 REAR AXLE RATIO | | |
| 424-001 | IRON REAR AXLE CARRIER WITH STANDARD AXLE HOUSING | | |
| 386-093 | RPL10 MERITOR SERVICE-FREE MAIN DRIVELINE WITH HALF ROUND (16T) YOKES | -20 | -20 |
| 452-001 | DRIVER CONTROLLED TRACTION DIFFERENTIAL | | 20 |
| 87B-001 | BLINKING LAMP WITH MODE SWITCH: DIFFERENTIAL UNLOCKS WITH IGNITION OFF; ACTIVE AT < 5 MPH, DEACTIVATES AT > 25 MPH | | |
| 423-028 | MERITOR 15X8.62 Q+ CAST SPIDER CAM REAR BRAKES; DOUBLE ANCHOR, FABRICATED SHOES | | -20 |
| 433-025 | FIRE AND EMERGENCY SEVERE SERVICE NON-ASBESTOS REAR BRAKE LINING | | |
| 451-001 | CAST IRON OUTBOARD REAR BRAKE DRUMS | | 20 |
| 440-006 | REAR OIL SEALS | | |
| 426-1B2 | BENDIX EVERSURE LONGSTROKE 1-DRIVE AXLE SPRING PARKING CHAMBERS | | |
| 428-031 | HALDEX AUTOMATIC REAR SLACK ADJUSTERS WITH STAINLESS STEEL CLEVIS PINS | | |
| 41T-003 | ROADRANGER SYNTHETIC FE 75W-90 LUBE | | |
| Rear Suspension | | | |
| FONT1 | LIQUIDSPRING DS150FR-A SUSPENSION WITH STANDARD HARDWARE AND CONTROLS; STANDARD LIMITED WARRANTY PROVIDED AND ADMINISTERED BY LIQUIDSPRING; AUTOMATIC CHAIN SYSTEM OPTIONAL | | -40 |
| 623-002 | TRANSVERSE AXLE MOUNTED CONTROL ROD | | |



Prepared for:
 NC SHERIFFS ASSOCIATION
 PO BOX 20049
 RALEIGH, NC
 27619
 CONTRACT 23-03-0524

Prepared by:
 Terry Keith
 Excel Truck Group
 4633 Equipment Drive
 Charlotte, NC 28269

| Data Code | Description | Weight Front | Weight Rear |
|---|--|--------------|-------------|
| Brake System | | | |
| 018-002 | AIR BRAKE PACKAGE | | |
| 490-121 | WABCO 4S/4M ABS WITH TRACTION CONTROL | | |
| 871-001 | REINFORCED NYLON, FABRIC BRAID, AND WIRE BRAID CHASSIS AIR LINES | | |
| 904-001 | FIBER BRAID PARKING BRAKE HOSE | | |
| 412-001 | STANDARD BRAKE SYSTEM VALVES | | |
| 46D-001 | STANDARD AIR SYSTEM PRESSURE PROTECTION; 85 PSI PROTECTION FOR AIR HORNS | | |
| 413-002 | STD U.S. FRONT BRAKE VALVE | | |
| 432-003 | RELAY VALVE WITH 5-8 PSI CRACK PRESSURE | | |
| 480-047 | BW AD-IS (DRM) BRAKE LINE AIR DRYER WITH SHIELD, HEATER, AND INTEGRAL RESERVOIR | | |
| 479-014 | AIR DRYER RESERVOIR MOUNTED | | |
| 460-001 | STEEL AIR BRAKE RESERVOIRS | | |
| 607-001 | CLEAR FRAME RAILS FROM BACK OF CAB TO FRONT REAR SUSPENSION BRACKET; BOTH RAILS OUTBOARD | | |
| 477-006 | BW DV-2 AUTO DRAIN VALVE WITHOUT HEATER ON ALL AIR TANKS | | |
| Chassis Electrical | | | |
| 335-004 | UPGRADED CHASSIS MULTIPLEXING UNIT | | |
| 32A-002 | UPGRADED BULKHEAD MULTIPLEXING UNIT | | |
| Preliminary Dimensions & Frame | | | |
| 545-442 | 174 INCH WHEELBASE | | |
| 546-101 | 11/32X3-1/2X10-15/16 INCH STEEL FRAME 120KSI | 10 | 120 |
| 552-030 | 63 INCH REAR FRAME OVERHANG | | |
| AC8-99D | CALC'D BACK OF CAB TO REAR SUSP C/L (CA): 108.66 in | | |
| 553-001 | SQUARE END OF FRAME | | |
| 550-001 | FRONT CLOSING CROSSMEMBER | | |
| 559-003 | LIGHTWEIGHT HEAVY DUTY ALUMINUM ENGINE CROSSMEMBER | -12 | |
| 561-001 | STANDARD CROSSMEMBER BACK OF TRANSMISSION | | |
| 562-001 | STANDARD CROSSMEMBERS | | |

Prepared for:
 NC SHERIFFS ASSOCIATION
 PO BOX 20049
 RALEIGH, NC
 27619
 CONTRACT 23-03-0524

Prepared by:
 Terry Keith
 Excel Truck Group
 4633 Equipment Drive
 Charlotte, NC 28269

| Data Code | Description | Weight Front | Weight Rear |
|--------------------------|--|--------------|-------------|
| Chassis Equipment | | | |
| 556-1CN | THREE-PIECE 14 INCH CHROME STEEL BUMPER WITH COLLAPSIBLE SAFETY ENDS; LH AND RH WING CUTOUTS FOR FEDERAL MS100 STYLE SQUARE SPEAKERS | 30 | |
| 558-001 | FRONT FRAME MOUNTED TOW HOOKS | 15 | |
| 574-001 | BUMPER MOUNTING FOR LICENSE PLATE | | |
| 586-024 | FENDER AND HOOD MOUNTED FRONT MUDFLAPS | | |
| 551-002 | HUCK-SPIN COLLAR CHASSIS FASTENERS | | |
| 489-032 | FACTORY INSTALLED BENDIX SMARTIRE TPMS WITH WHEEL RIM MOUNTED SENSORS; GAUGE MOUNTED IN DASH | 6 | 6 |
| 605-103 | D15-28195-000 CENTER PUNCH TO MARK CENTERLINE OF REAR SUSPENSION ON TOP FLANGE OF FRAME | | |
| Fuel Tanks | | | |
| 206-190 | 40 GALLON POLISHED RECTANGULAR ALUMINUM FUEL TANK - RH | 70 | 20 |
| 204-217 | 34 GALLON POLISHED RECTANGULAR ALUMINUM FUEL TANK - LH | | |
| 212-007 | FUEL TANKS FORWARD UNDER CAB | | |
| 664-004 | POLISHED STAINLESS STEEL STEPS | | |
| 207-005 | FUEL TANK FILLER NECK ANTI-SIPHON INSERT | | |
| 205-002 | CHROME FUEL TANK CAPS | | |
| 122-1J1 | DETROIT FUEL/WATER SEPARATOR WITH WATER IN FUEL SENSOR, HAND PRIMER, AND 12 VOLT PREHEATER" | -5 | |
| 216-020 | EQUIFLO INBOARD FUEL SYSTEM | | |
| 20E-002 | AUXILIARY FUEL SUPPLY AND RETURN PORTS LOCATED ON RH FUEL TANK | | |
| 202-016 | HIGH TEMPERATURE REINFORCED NYLON FUEL LINE | | |
| Tires | | | |
| 093-1TM | MICHELIN X MULTI Z 285/70R19.5 16 PLY RADIAL FRONT TIRES | -64 | |
| 094-1TN | MICHELIN X MULTI D 285/70R19.5 16 PLY RADIAL REAR TRACTION TIRES | | -64 |
| Hubs | | | |
| 418-058 | CONMET PRESET PLUS PREMIUM ALUMINUM FRONT HUBS | -30 | |

Prepared for:
 NC SHERIFFS ASSOCIATION
 PO BOX 20049
 RALEIGH, NC
 27619
 CONTRACT 23-03-0524

Prepared by:
 Terry Keith
 Excel Truck Group
 4633 Equipment Drive
 Charlotte, NC 28269

| Data Code | Description | Weight Front | Weight Rear |
|---------------------|--|--------------|-------------|
| 450-058 | CONMET PRESET PLUS PREMIUM ALUMINUM REAR HUBS | | -30 |
| Wheels | | | |
| 502-1E5 | POLISHED ALCOA 77362X 19.5X7.50 10-HUB PILOT ALUMINUM DISC FRONT WHEELS | -64 | |
| 505-1E5 | POLISHED ALCOA 77362X 19.5X7.50 10-HUB PILOT ALUMINUM DISC REAR WHEELS | | -128 |
| 50W-005 | BENDIX SMARTIRE TIRE PRESSURE MONITORING SYSTEM SENSORS FRONT AND REAR WHEELS | | 8 |
| 498-1AB | INNER WHEEL EXTENSIONS: OUTBOARD AIRING FOR ALUMINUM OUTER WHEELS WITH RUBBER STABILIZERS | | |
| Cab Exterior | | | |
| 829-071 | 106 INCH BBC ALUMINUM CONVENTIONAL SAFETY CAB | | |
| 650-009 | RUBBER CAB MOUNTS | | |
| 705-012 | CAB REINFORCEMENTS FOR ROOF MOUNTED LIGHTBAR | 2 | |
| 648-002 | NONREMOVABLE BUGSCREEN MOUNTED BEHIND GRILLE | | |
| 678-067 | SAFETY YELLOW LH AND RH INTERIOR GRAB HANDLES; LH AND RH EXTERIOR GRAB HANDLES WITH SINGLE RUBBER INSERT | | |
| 646-023 | HOOD MOUNTED CHROMED PLASTIC GRILLE | | |
| 65X-003 | CHROME HOOD MOUNTED AIR INTAKE GRILLE | | |
| 644-004 | FIBERGLASS HOOD | | |
| 690-017 | HOOD LINER, ADDED FIREWALL, AND ADDED FLOOR HEAT INSULATION | 5 | |
| 727-1B0 | DUAL 25 INCH ROUND HADLEY STUTTER TONE HOOD MOUNTED AIR HORNS | 8 | |
| 726-001 | SINGLE ELECTRIC HORN | | |
| 728-002 | DUAL HORN SHIELDS | | |
| 657-001 | DOOR LOCKS AND IGNITION SWITCH KEYED THE SAME | | |
| 78G-006 | KEY QUANTITY 6 | | |
| 575-001 | REAR LICENSE PLATE MOUNT END OF FRAME | | |
| 312-088 | LED HEADLIGHT ASSEMBLY WITH INCANDESCENT MARKER/TURN LAMPS; CHROME BEZEL | | |
| 302-047 | LED AERODYNAMIC MARKER LIGHTS | | |
| 311-019 | HEADLIGHTS ON WITH WIPERS; DAYTIME RUNNING LIGHTS | | |



Prepared for:
 NC SHERIFFS ASSOCIATION
 PO BOX 20049
 RALEIGH, NC
 27619
 CONTRACT 23-03-0524

Prepared by:
 Terry Keith
 Excel Truck Group
 4633 Equipment Drive
 Charlotte, NC 28269

| Data Code | Description | Weight Front | Weight Rear |
|-----------|---|--------------|-------------|
| 294-094 | OMIT STOP/TAIL/BACKUP LIGHTS AND PROVIDE WIRING WITH SEPARATE STOP/TAIL WIRES TO 7 FEET BEYOND END OF FRAME | | -5 |
| 300-015 | STANDARD FRONT TURN SIGNAL LAMPS | | |
| 469-014 | AUTOMATIC ON/OFF ENGINE COMPARTMENT HOOD ACTIVATED WORK LIGHT WITH MANUAL OVERRIDE | 1 | |
| 744-103 | DUAL WEST COAST BRIGHT FINISH HEATED MIRRORS WITH LED LIGHTS AND LH AND RH REMOTE | | |
| 797-001 | DOOR MOUNTED MIRRORS | | |
| 796-001 | 102 INCH EQUIPMENT WIDTH | | |
| 743-204 | LH AND RH 8 INCH BRIGHT FINISH HEATED CONVEX MIRRORS MOUNTED UNDER PRIMARY MIRRORS | | |
| 74A-001 | RH DOWN VIEW MIRROR | | |
| 729-001 | STANDARD SIDE/REAR REFLECTORS | | |
| 677-016 | DUAL LEVEL CAB ENTRY STEPS ON BOTH SIDES | | |
| 275-061 | PARK BRAKE REMINDER WARNING SYSTEM | | |
| 764-010 | COMPOSITE EXTERIOR SUN VISOR | 10 | |
| 768-998 | NO REAR WINDOW | -20 | |
| 661-003 | TINTED DOOR GLASS LH AND RH WITH TINTED NON-OPERATING WING WINDOWS | | |
| 654-027 | RH AND LH ELECTRIC POWERED WINDOWS, PASSENGER SWITCHES ON DOOR | 4 | |
| 663-013 | 1-PIECE SOLAR GREEN GLASS WINDSHIELD | | |
| 659-020 | 2 GALLON WINDSHIELD WASHER RESERVOIR WITH FLUID LEVEL INDICATOR, FRAME MOUNTED | | |

Cab Interior

| | | | |
|---------|--|--|--|
| 707-1AK | OPAL GRAY VINYL INTERIOR | | |
| 706-026 | MOLDED PLASTIC DOOR PANEL WITHOUT VINYL INSERT WITH ALUMINUM KICKPLATE LOWER DOOR | | |
| 708-026 | MOLDED PLASTIC DOOR PANEL WITHOUT VINYL INSERT WITH ALUMINUM KICKPLATE LOWER DOOR | | |
| 772-006 | BLACK MATS WITH SINGLE INSULATION | | |
| 691-014 | FORWARD ROOF MOUNTED CONSOLE WITH UPPER STORAGE COMPARTMENTS AND ADDITIONAL CENTER COMPARTMENT WITHOUT NETTING | | |
| 694-010 | IN DASH STORAGE BIN | | |

Prepared for:
 NC SHERIFFS ASSOCIATION
 PO BOX 20049
 RALEIGH, NC
 27619
 CONTRACT 23-03-0524

Prepared by:
 Terry Keith
 Excel Truck Group
 4633 Equipment Drive
 Charlotte, NC 28269

| Data Code | Description | Weight Front | Weight Rear |
|-----------|--|--------------|-------------|
| 742-007 | (2) CUP HOLDERS LH AND RH DASH | | |
| 680-006 | GRAY/CHARCOAL FLAT DASH | | |
| 860-004 | SMART SWITCH EXPANSION MODULE | | |
| 700-002 | HEATER, DEFROSTER, AND AIR CONDITIONER | | |
| 701-013 | STANDARD HVAC DUCTING WITH PRE-FILTER FOR OUTSIDE AIR INTAKE | | |
| 703-005 | MAIN HVAC CONTROLS WITH RECIRCULATION SWITCH | | |
| 170-045 | STANDARD HEATER PLUMBING WITH BALL SHUTOFF VALVES AT SUPPLY LINES ONLY | | |
| 130-043 | (1) VALEO HEAVY DUTY AND (1) SANDEN COMPACT REFRIGERANT COMPRESSORS | 20 | |
| 702-002 | BINARY CONTROL: R-134A | | |
| 739-034 | ADDED PREMIUM CAB INSULATION | | |
| 285-027 | SOLID-STATE CIRCUIT PROTECTION AND FUSES WITH SPARE FUSE KIT | | |
| 280-007 | 12V NEGATIVE GROUND ELECTRICAL SYSTEM | | |
| 324-011 | DOME DOOR LIGHTD: ACTIVATED LH AND RH, DUAL READING LIGHTS, AND FORWARD CAB ROOF | | |
| 655-005 | ELECTRIC DOOR LOCKS | | |
| 284-101 | (1) 12V POWER SUPPLY AND (1) DUAL 2.1 AMP USB CHARGER IN DASH | | |
| 756-339 | PREMIUM ISRINGHAUSEN HIGH BACK AIR SUSPENSION DRIVERS SEAT WITH 2 AIR LUMBAR, INTEGRATED CUSHION EXTENSION, TILT, AND ADJUSTABLE SHOCK | 70 | |
| 760-339 | PREMIUM ISRINGHAUSEN HIGH BACK AIR SUSPENSION PASSENGER SEAT WITH 2 AIR LUMBAR, INTEGRATED CUSHION EXTENSION, TILT, AND ADJUSTABLE SHOCK | 60 | 20 |
| 759-002 | INBOARD DRIVER AND PASSENGER SEAT ARMRESTS | 4 | |
| 711-004 | LH AND RH INTEGRAL DOOR PANEL ARMRESTS | | |
| 758-014 | BLACK CORDURA PLUS CLOTH DRIVER SEAT COVER | | |
| 761-014 | BLACK CORDURA PLUS CLOTH PASSENGER SEAT COVER | | |
| 763-104 | HIGH VISIBILITY ORANGE SEAT BELTS WITH DRIVER INDICATOR LIGHT AND AUDIBLE ALARM | | |
| 532-002 | ADJUSTABLE TILT AND TELESCOPING STEERING COLUMN | 10 | |
| 540-015 | 4-SPOKE 18 INCH STEERING WHEEL | | |



Prepared for:
 NC SHERIFFS ASSOCIATION
 PO BOX 20049
 RALEIGH, NC
 27619
 CONTRACT 23-03-0524

Prepared by:
 Terry Keith
 Excel Truck Group
 4633 Equipment Drive
 Charlotte, NC 28269

| Data Code | Description | Weight Front | Weight Rear |
|-----------------------------------|--|--------------|-------------|
| 765-002 | DRIVER AND PASSENGER INTERIOR SUN VISORS | | |
| Instruments & Controls | | | |
| 732-003 | WOODGRAIN DRIVER INSTRUMENT PANEL | | |
| 734-003 | WOODGRAIN CENTER INSTRUMENT PANEL | | |
| 870-001 | BLACK GAUGE BEZELS | | |
| 486-001 | LOW AIR PRESSURE INDICATOR LIGHT AND AUDIBLE ALARM | | |
| 840-002 | 2 INCH PRIMARY AND SECONDARY AIR PRESSURE GAUGES | | |
| 198-034 | INTAKE MOUNTED AIR RESTRICTION INDICATOR W/ COLOR LED WARNING LIGHT, 18 INCH AND 20 INCH LIMITS | | |
| 721-003 | 1040 87 DECIBELS TO 112 DECIBELS AUTOMATIC SELF-ADJUSTING BACKUP ALARM | | 3 |
| 149-013 | ELECTRONIC CRUISE CONTROL WITH SWITCHES IN LH SWITCH PANEL | | |
| 156-007 | KEY OPERATED IGNITION SWITCH AND INTEGRAL START POSITION; 4 POSITION OFF/RUN/START/ACCESSORY | | |
| 811-042 | ICU3S, 132X48 DISPLAY WITH DIAGNOSTICS, 28 LED WARNING LAMPS AND DATA LINKED | | |
| 160-038 | HEAVY DUTY ONBOARD DIAGNOSTICS INTERFACE CONNECTOR LOCATED BELOW LH DASH | | |
| 844-001 | 2 INCH ELECTRIC FUEL GAUGE | | |
| 856-001 | ELECTRICAL ENGINE COOLANT TEMPERATURE GAUGE | | |
| 864-001 | 2 INCH TRANSMISSION OIL TEMPERATURE GAUGE | | |
| 830-017 | ENGINE AND TRIP HOUR METERS INTEGRAL WITHIN DRIVER DISPLAY | | |
| 33A-051 | WIRING PROVISION FOR CUSTOMER FURNISHED ROOF MOUNTED LIGHTBAR WITH 2 WIRES; HANDLES UP TO 30 AMPS OF CURRENT | | |
| 49B-004 | WABCO ELECTRONIC STABILITY CONTROL | | |
| 852-002 | ELECTRIC ENGINE OIL PRESSURE GAUGE | | |
| 746-136 | PANA-PACIFIC AM/FM/WB WORLD TUNER RADIO WITH AUXILIARY INPUT, J1939 | 10 | |
| 747-001 | DASH MOUNTED RADIO | | |
| 750-002 | (2) RADIO SPEAKERS IN CAB | | |
| 753-040 | 24 INCH AM/FM ANTENNA MOUNTED ON LH SIDE MIRROR; NO HOLE IN ROOF | | |



Prepared for:
 NC SHERIFFS ASSOCIATION
 PO BOX 20049
 RALEIGH, NC
 27619
 CONTRACT 23-03-0524

Prepared by:
 Terry Keith
 Excel Truck Group
 4633 Equipment Drive
 Charlotte, NC 28269

| Data Code | Description | Weight Front | Weight Rear |
|-----------|--|--------------|-------------|
| 74D-002 | RADIO WIRING WITH POWER CUTOFF WHEN VEHICLE IN REVERSE GEAR | | |
| 810-027 | ELECTRONIC MPH SPEEDOMETER WITH SECONDARY KPH SCALE; WITHOUT ODOMETER | | |
| 817-001 | STANDARD VEHICLE SPEED SENSOR | | |
| 812-001 | ELECTRONIC 3000 RPM TACHOMETER | | |
| 81Y-001 | PRE-TRIP LAMP INSPECTION: ALL OUTPUTS FLASH WITH SMART SWITCH | | |
| 264-028 | (2) LH AND RH FOOT SWITCHES WITH DASH SWITCH FOR HORN BUTTON TO CONTROL AIR HORN, DEFAULTS TO ELECTRIC <85 PSI | | |
| 836-015 | DIGITAL VOLTAGE DISPLAY INTEGRAL WITH DRIVER DISPLAY | | |
| 660-025 | SINGLE ELECTRIC WINDSHIELD WIPER MOTOR WITH DELAY PROGRAMMED TO SLOWEST SPEED WITH PARK BRAKE SET | | |
| 304-001 | MARKER LIGHT SWITCH INTEGRAL WITH HEADLIGHT SWITCH | | |
| 27D-004 | ALTERNATING FLASHING WIG WAG HEADLAMP SYSTEM WITH BODY BUILDER CONTROLLED ENGAGEMENT | | |
| 882-017 | ONE VALVE PARKING BRAKE SYSTEM WITH SHIFTER CONTROLLED AUTOPARK AND WARNING INDICATOR | | |
| 299-013 | SELF CANCELING TURN SIGNAL SWITCH WITH DIMMER, WASHER/WIPER, AND HAZARD IN HANDLE | | |
| 298-039 | INTEGRAL ELECTRONIC TURN SIGNAL FLASHER WITH HAZARD LAMPS OVERRIDING STOP LAMPS | | |

Design

065-000 PAINT: ONE SOLID BC/CC AXALTA COLOR

Color: Final TBD

980-6A7 CAB COLOR A: L3007EY OSHA RED ELITE EY
 986-020 BLACK POLYURETHANE CHASSIS PAINT
 976-995 SUNVISOR PAINTED SAME AS CAB COLOR A
 963-003 STANDARD DAIMLER E COAT/UNDERCOATING

Certification / Compliance

996-009 U.S. AND CANADA (DUAL CERTIFICATION)

Secondary Factory Options

998-001 CORPORATE PDI CENTER IN-SERVICE

Prepared for:
 NC SHERIFFS ASSOCIATION
 PO BOX 20049
 RALEIGH, NC
 27619
 CONTRACT 23-03-0524

Prepared by:
 Terry Keith
 Excel Truck Group
 4633 Equipment Drive
 Charlotte, NC 28269

| Data Code | Description | Weight Front | Weight Rear |
|-----------|------------------------------------|--------------|-------------|
| 99B-001 | SHIP TO FONTAINE (MOUNT HOLLY, NC) | | |

Chassis Weight Summary

| | | | |
|----------------|-----------|-----------|-----------|
| Factory Weight | 5891 lbs. | 3373 lbs. | 9264 lbs. |
|----------------|-----------|-----------|-----------|

Standard Excel Warranties

- WBB-344 TC4 CHASSIS: 5 YEARS OR 100,000 MILES EXTENDED COVERAGE
- WAL-231 AXLES: 5 YEARS OR 100,000 MILES EXTENDED COVERAGE
- WAG-014 TOWING: 5 YEARS/UNLIMITED MILES EXTENDED TOWING COVERAGE; \$550 CAP PER COVERED TOW
- CUMMINS B6.7 FIRE/RESCUE: *STANDARD* 5 YEARS OR 100,000 MILES
- ALLISON 2500 EVS: *STANDARD* 5 YEARS/UNLIMITED MILES

D I M E N S I O N S

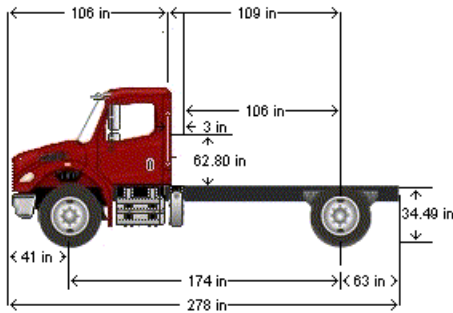

Prepared for:
NC SHERIFFS ASSOCIATION
PO BOX 20049
RALEIGH, NC
27619
CONTRACT 23-03-0524

Prepared by:
Terry Keith
Excel Truck Group
4633 Equipment Drive
Charlotte, NC 28269

2023 *Excel* Freightliner M2-106 Ambulance Chassis Features

- **CAB SAFETY:** Aluminum cab with steel doors and high strength steel and aluminum alloy reinforcements; meets (US) SAE J2422 roof crush, (Euro) ECE R29 back wall impact, and (Sweden) TSVS 1981:21 A-pillar impact safety certifications.
- **STOPPING SAFETY:** CAAS 2.0 requires "...OEM'S best available..." brakes with ABS. We offer *Meritor* air brakes with automatic slack adjusters; non-asbestos brake pads; *Cummins* 18.7 ft³ air compressor with air drier; automatic air tank moisture purge valves.
- **IN-TRANSIT SAFETY:** *WABCO* 4 channel ABS with required traction control; *WABCO* electronic stability control for anti-rollover assist; *Bendix* SmarTire automatic tire pressure monitoring system.
- **ERGONOMICS:** Premium *Freightliner* (by *Isringhausen*) multi-position high back air-ride seats with inboard arm rests, *Cordura Plus* cloth seat covers (vinyl option), and safety orange seat belts with warning.
- Exterior grab handles with rubber inserts, and safety yellow interior grab handles on A and B pillars.
- Dual hood mounted *Hadley* stutter-tone horns with dual foot controls (lanyards optional at no cost); dual square (*Federal*-style) speaker cutouts in bumper.
- LED headlights with factory installed body builder wig-wag provisions; LED marker lights; under hood work light; LED step lights.
- *Mekra* heated remote control mirrors with large heated square convex mirrors; RH down view mirror.
- Steel 120KSI frame with *Huck-Spin* fasteners to reduce frame flex.
- Driver controlled locking differential with lighted switch and warning buzzer; 25MPH limit.
- *Michelin* 285/70R X 19.5 tires; *ALCOA* 19.5" polished aluminum wheels.
- *Delco* 275 AMP 28-SI pad mounted alternator; (2) *Odyssey* AGM starting and cycling batteries, 12 volt Group 31, 2300 CCA, threaded studs.
- Premium cab, firewall, floor, and hood insulation.
- *Taperleaf* front springs with *Bilstein* shocks and anti-sway bar; *LiquidSpring* rear suspension package and controls; Optional *Rotogrip* automatic chain system (*not standard*).
- Multiple cab and chassis electrical tap points for accessory power; cab mounted battery disconnect.
- *5 years or 100,000 miles bumper-to-bumper chassis and power train warranty* (some exclusions apply); longer time and/or mileage options for most components are available for additional cost.

